

OWNER'S MANUAL

Operation

Maintenance

Specifications

All information in this Owner's Manual is current at the time of publication. However, HYUNDAI reserves the right to make changes at any time so that our policy of continual product improvement may be carried out.

This manual applies to all models of this vehicle and includes descriptions and explanations of optional as well as standard equipment.

As a result, you may find material in this manual that does not apply to your specific vehicle.

Please note that some models are equipped with Right-Hand Drive (RHD). The explanations and illustrations for some operations in RHD models are opposite of those written in this manual.

CAUTION: MODIFICATIONS TO YOUR HYUNDAI

Your HYUNDAI should not be modified in any way. Such modifications may adversely affect the performance, safety or durability of your HYUNDAI and may, in addition, violate conditions of the limited warranties covering the vehicle. Certain modifications may also be in violation of regulations established by the Department of Transportation and other government agencies in your country.

TWO-WAY RADIO OR CELLULAR TELEPHONE INSTALLATION

Your vehicle is equipped with electronic components. It is possible for an improperly installed/adjusted two-way radio or cellular telephone to adversely affect electronic systems. For this reason, we recommend that you carefully follow the radio manufacturer's instructions or consult your HYUNDAI dealer for precautionary measures or special instructions if you choose to install one of these devices.

WARNING! (IF EQUIPPED)

The vehicle is equipped with a device of the system Pan-European eCall or UAE eCALL which calls emergency services. Any self- or unauthorized interference in the system Pan-European eCall or UAE eCALL in vehicle systems and its components, installing of equipment which is not recommended by vehicle manufacturer and/or in authorized HYUNDAI dealer can cause incorrect operation (of the device of) the system Pan-European eCall or UAE eCALL making erroneous calls, causing failure of the device (in cars) in case of traffic accident or other accidents, when you need emergency care. This may be dangerous and threaten your life!

SAFETY AND VEHICLE DAMAGE WARNING

This manual includes information titled as DANGER, WARNING, CAUTION and NOTICE. These titles indicate the following:

DANGER

DANGER indicates a hazardous situation which, if not avoided, will result in death or serious injury.

WARNING

WARNING indicates a hazardous situation which, if not avoided, could result in death or serious injury.

CAUTION

CAUTION indicates a hazardous situation which, if not avoided, could result in minor or moderate injury.

NOTICE

NOTICE indicates a situation which, if not avoided, could result in vehicle damage.

Table of contents

Information/Getting started with your electric vehicle	1
Vehicle information	2
Seats & Safety system	3
Instrument Cluster	4
Convenience Features	5
Driving your vehicle	6
Driver assistance system	7
Emergency situations	8
Maintenance	9
Index	I

1. Information/Getting started with your electric vehicle

Information	1-3
HYUNDAI Motor Company	1-3
How to use this manual.....	1-4
Safety messages.....	1-5
Vehicle modifications.....	1-6
Vehicle handling instructions	1-6
Returning used vehicles.....	1-6
Vehicle data collection and event data recorders	1-7
About "Getting started with your electric vehicle"	1-8
Understanding your electric vehicle	1-8
Characteristics of your electric vehicle.....	1-8
Precautions when using the high voltage battery.....	1-10
Other precautions for electric vehicle management	1-11
Charging your electric vehicle.....	1-12
Safety precautions for charging your electric vehicle	1-12
Checking basic information on charging your electric vehicle	1-16
Using an AC charger	1-21
Using a DC charger	1-23
Using a portable charger (ICCB).....	1-25
Using the scheduled charging function	1-29
Checklist when charging does not start.....	1-30
Using Electric Vehicle functions.....	1-31
Checking the Electric Vehicle screen configuration	1-31
Checking energy information	1-32
Setting the next departure time.....	1-34
Setting the charging and climate	1-35
Setting a battery discharging limit when using Vehicle to Load (V2L)	1-37
Setting electric vehicle specialized functions	1-38
Using V2L function	1-42
Safety precautions when using the V2L function.....	1-42
Using electricity outside the vehicle	1-44
Using electricity inside the vehicle	1-45
Solving V2L problems	1-47
Aux. Battery Saver+	1-48

1

Driving your electric vehicle.....	1-49
Starting and stopping the vehicle	1-49
Checking electric vehicle driving information	1-50
Countermeasures for accidents or fire.....	1-60
If the electric vehicle catches fire	1-60
If the electric vehicle is submerged	1-60
If the electric vehicle needs towing	1-61
Other precautions for electric vehicle accidents	1-62

Information

Congratulations, and thank you for choosing HYUNDAI. We are pleased to welcome you to the growing number of discerning people who drive HYUNDAs. We are very proud of the advanced engineering and high-quality construction of each HYUNDAI we build.

Your Owner's Manual will introduce you to the features and operation of your new HYUNDAI. To become familiar with your new HYUNDAI, so that you can fully enjoy it, read this Owner's Manual carefully before driving your new vehicle.

This manual contains important safety information and instructions intended to familiarize you with your vehicle's controls and safety features so you can safely operate your vehicle.

This manual also contains information on maintenance designed to enhance safe operation of the vehicle. It is recommended that all service and maintenance on your car be performed by an authorized HYUNDAI dealer. HYUNDAI dealers are prepared to provide high-quality service, maintenance and any other assistance that may be required.

This Owner's Manual should be considered a permanent part of your vehicle, and should be kept in the vehicle so you can refer to it at any time. The manual should stay with the vehicle if you sell it to provide the next owner with important operating, safety and maintenance information.

HYUNDAI MOTOR COMPANY

CAUTION

Severe vehicle damage may result from the use of poor quality lubricants that do not meet HYUNDAI specifications. You must always use high quality lubricants that meet the specifications listed in the Electric vehicle specifications section of the Owner's Manual.

Copyright 2024 HYUNDAI Motor Company. All rights reserved. No part of this publication may be reproduced, stored in any retrieval system or transmitted in any form or by any means without the prior written permission of HYUNDAI Motor Company.

HOW TO USE THIS MANUAL

We want to help you get the greatest possible driving pleasure from your vehicle. Your Owner's Manual can assist you in many ways. We strongly recommend that you read the entire manual. In order to minimize the chance of death or injury, you must read the WARNING and CAUTION sections in the manual.

Illustrations complement the words in this manual to best explain how to enjoy your vehicle. By reading your manual, you will learn about features, important safety information, and driving tips under various road conditions.

The general layout of the manual is provided in the Table of Contents. Use the index when looking for a specific area or subject; it has an alphabetical listing of all information in your manual.

Sections: This manual has nine chapters plus an index. Each section begins with a brief list of contents so you can tell at a glance if that section has the information you want.

SAFETY MESSAGES

Your safety, and the safety of others, is very important. This Owner's Manual provides you with many safety precautions and operating procedures. This information alerts you to potential hazards that may hurt you or others, as well as damage to your vehicle.

Safety messages found on vehicle labels and in this manual describe these hazards and what to do to avoid or reduce the risks.

Warnings and instructions contained in this manual are for your safety. Failure to follow safety warnings and instructions can lead to serious injury or death.

Throughout this manual DANGER, WARNING, CAUTION, NOTICE and the SAFETY ALERT SYMBOL will be used.



This is the safety alert symbol. It is used to alert you to potential physical injury hazards. Obey all safety messages that follow this symbol to avoid possible injury or death. The safety alert symbol precedes the signal words DANGER, WARNING and CAUTION.

DANGER

DANGER indicates a hazardous situation which, if not avoided, will result in death or serious injury.

WARNING

WARNING indicates a hazardous situation which, if not avoided, could result in death or serious injury.

CAUTION

CAUTION indicates a hazardous situation which, if not avoided, could result in minor or moderate injury.

NOTICE

NOTICE indicates a situation which, if not avoided, could result in vehicle damage.

VEHICLE MODIFICATIONS

- This vehicle should not be modified. Modification of your vehicle could affect its performance, safety or durability and may even violate governmental safety and emissions regulations.
In addition, damage or performance problems resulting from any modification may not be covered under warranty.
- If you use unauthorized electronic devices, it may cause the vehicle to operate abnormally, wire damage, battery discharge and fire.

VEHICLE HANDLING INSTRUCTIONS

As with other vehicles of this type, failure to operate this vehicle correctly may result in loss of control, an accident or vehicle rollover.

Specific design characteristics (higher ground clearance, track, etc.) give this vehicle a higher center of gravity than other types of vehicles. In other words they are not designed for cornering at the same speeds as conventional 2-wheel drive vehicles. Avoid sharp turns or abrupt maneuvers. Again, failure to operate this vehicle correctly may result in loss of control, an accident or vehicle rollover. Be sure to read the "Reducing the risk of a rollover" driving guidelines, in section 6 of this manual.

RETURNING USED VEHICLES

HYUNDAI promotes an environmentally sound treatment for end of life vehicles and offers to take back your HYUNDAI end of life vehicles in accordance with the European Union (EU) End of Life Vehicles Directive.

You can get detailed information from your national HYUNDAI website.

Vehicle data collection and event data recorders

This vehicle is equipped with an event data recorder (EDR). The main purpose of an EDR is to record, in certain crash or near crash-like situations, such as an air bag deployment or hitting a road obstacle, data that will assist in understanding how a vehicle's systems performed. The EDR is designed to record data related to vehicle dynamics and safety systems for a short period of time, typically 30 seconds or less. The EDR in this vehicle is designed to record such data as:

- How various systems in your vehicle were operating
- Whether or not the driver and passenger safety belts were buckled/fastened
- How far (if at all) the driver was depressing the accelerator and/or brake pedal
- How fast the vehicle was traveling

These data can help provide a better understanding of the circumstances in which collisions and injuries occur.

i Information

EDR data is recorded by your vehicle only if a non-trivial crash situation occurs; no data are recorded by the EDR under normal driving conditions and no personal data (for example, name, gender, age, and crash location) are recorded. However, other parties, such as law enforcement, could combine the EDR data with the type of personally identifying data routinely acquired during a crash investigation.

To read data recorded by an EDR, special equipment is required, and access to the vehicle or the EDR is needed. In addition to the vehicle manufacturer, other parties, such as law enforcement, that have the special equipment, can read the information if they have access to the vehicle or the EDR.

About "Getting started with your electric vehicle"

"Getting started with your electric vehicle" provides information about new technologies applied to the vehicle and explains how to use the main features. "Getting started with your electric vehicle" allows you to quickly and easily understand new vehicle features and how to operate them conveniently.

- Before driving, carefully read the manual provided with the vehicle and follow all safety information and precautions for every vehicle feature.
- "Getting started with your electric vehicle" covers all optional specifications. It may include descriptions for features that are not equipped in the vehicle.
- Images of the exterior and interior of the vehicle in "Getting started with your electric vehicle" may differ from the actual vehicle.

Understanding your electric vehicle

Electric vehicles are driven using a battery and an electric motor. Understand the characteristics of your electric vehicle and check the features that you must know before driving it.

Characteristics of your electric vehicle

The characteristics that differentiate electric vehicles from gasoline and diesel vehicles are as follows:

- Electric vehicles are eco-friendly because they do not use fossil fuels for driving. Additionally, unlike gasoline and diesel vehicles, noise and vibration are minimal, and the vehicle's lifespan is relatively long.
- When slowing down or driving downhill, regenerative braking is used. Regenerative braking charges the high voltage battery and minimizes energy loss.
- If the high voltage battery is running low, you can charge the vehicle using the AC charger, DC charger, or portable charging cables. For more information, see "Charging your electric vehicle".

i Information

Regenerative braking uses an electric motor when decelerating and braking, and it transforms kinetic energy to electrical energy in order to charge the high voltage battery.

Battery information

The batteries used in the electric vehicle are as follows:

- **High voltage battery (high-capacity):** Drives the motor and operates the air conditioner. It can be charged via an AC charger, DC charger, or portable charger.
- **12 V battery:** Operates all lamps, wipers, and audio system. It is automatically charged while the READY indicator is displayed on the instrument cluster or the high voltage battery is charged.

Main components of your electric vehicle

The main components of your electric vehicle and their functions are as follows:

- **On-Board Charger (OBC):** Charges the high voltage battery by converting the power grid's AC power to DC power.
- **Inverter:** Converts power from direct current (DC) to alternating current (AC) and supplies power to the motor, and converts power from AC to DC and charge the high voltage battery during deceleration and braking.
- **Low Voltage DC-DC Converter (LDC):** Converts the high voltage battery's power source to a low voltage (12 V) power source and supply power to the electrical devices in the vehicle.
- **Vehicle Control Unit (VCU):** Controls the various controllers and sensors on the vehicle.
- **Motor:** Uses electricity accumulated in the high voltage battery to drive the vehicle (same role as an engine in gasoline and diesel vehicles).
- **Reduction gear:** Delivers the rotational force of the motor to the tires at appropriate speeds and torque.
- **High voltage battery (Lithium-ion battery):** Stores and supplies power necessary for the electric vehicle to operate. (The separately installed 12 V battery provides power to the vehicle when the vehicle is in **ACC** or **OFF**.)

WARNING

- Do not remove or disassemble any high voltage battery's connectors and wires. Doing so may lead to accidents, such as electric shock, and result in serious injury and significantly degrade the vehicle's performance and durability.
 - When the high voltage battery or its related components require inspection and maintenance, we recommend that you contact an authorized HYUNDAI dealer.
-

Precautions when using the high voltage battery

Precautions for high voltage battery when driving and storing the vehicle are as follows:

CAUTION

- Keep the gauge of the high voltage battery from going below than 10 %. Storing the vehicle while the battery level is low for a long time may damage the battery or reduce the battery's capacity, potentially causing the need for a battery replacement.
 - If a collision occurs and the vehicle is impacted, we recommend that your vehicle be inspected by an authorized HYUNDAI dealer to check the battery connection status.
 - Using the V2L function may reduce the driving distance due to the use of the high voltage battery energy, and repeated use of the V2L function may cause a decrease in the life of the high voltage battery.
 - Repeated use of a DC charger may cause a decrease in the life of the high voltage battery.
 - The high voltage battery level may reduce naturally even if the vehicle is not driven.
 - Storing the vehicle in temperatures that are too hot or cold may degrade the battery performance.
 - The distance to empty or power output may vary depending on the driving conditions, such as the outside temperature. Driving at high speeds or uphill may increase battery consumption, resulting in a shorter distance to empty.
 - If you use the air conditioning or heating, which is powered by the high voltage battery, the distance to empty may decrease. Maintain proper temperature when using the air conditioning or heating.
 - Depending on the vehicle's period of use, natural degradation of the battery may occur, so the distance to empty may decrease. When the charge capacity and distance to empty keep failing, we recommend that your vehicle be inspected by an authorized HYUNDAI dealer.
 - If you do not use the vehicle for a long time, charge the vehicle at least once every 3 months to prevent the battery from fully discharging. When the battery level has lower power, immediately charge the vehicle.
 - To keep the battery in optimal condition, use AC charging. Fully charging the battery when it is 20 % or lower helps to keep the battery in optimal condition. (Charging once a month or more is recommended.)
 - The charging level value displayed on the instrument cluster may decrease according to the charging conditions (charger status, outside temperature, battery temperature, etc.). For longer battery life and safety, after a certain charging level is reached, the charging current is gradually lowered to fully charge the battery.
-

Other precautions for electric vehicle management

CAUTION

- If post repair heat treatment after repairs or painting is required after an accident, the high voltage battery's performance may be degraded. If heat treatment is required, we recommend that you contact an authorized HYUNDAI dealer.
- When cleaning the motor compartment, do not use a high-pressure washer. Doing so may result in electric shock, due to a discharge in high voltage electricity, or damage the vehicle's electric system.
- Do not install third-party parts or modified parts on the vehicle. Doing so may damage the electric power system. Only use or install genuine parts.

High voltage cut-off switch

High voltage cut-off switch is a device located inside the motor compartment to block the battery's high voltage when your vehicle is inspected at an authorized HYUNDAI dealer.

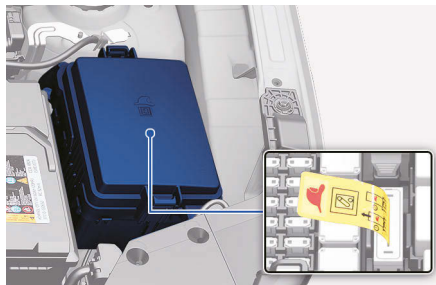

WARNING

- Never touch the high voltage cut-off switch. This could result in serious injury or death in a collision or electric shock.
- If the high voltage cut-off switch requires an inspection or repair, we recommend that you contact an authorized HYUNDAI dealer.
- Never disconnect or cut the high voltage cut-off switch except in an emergency situation. Serious problems may occur, such as the vehicle may not start.

Charging your electric vehicle

Check the detailed information about charging an electric vehicle and charge your vehicle.

Electric vehicles can be charged via an AC charger or DC charger installed at public charging stations. If the vehicle cannot be moved to a public charging station in the event of an emergency, you can charge the vehicle via the In-Cable Control Box (ICCB) with a power source (AC 220 V/230 V).

Safety precautions for charging your electric vehicle

Before charging your electric vehicle, carefully read and follow all the safety information below. Failure to do so may cause electric shock or fire and result in a serious injury, death, malfunctions, or property damage.

Precautions for electric medical devices

WARNING

Electromagnetic waves that are generated from the charger can seriously impact electric medical devices, such as an implantable cardiac pacemaker. When using such devices, make sure to consult with your doctor and the manufacturer to find out whether charging your electric vehicle will impact the operation of your device.

Basic safety precautions for charging

WARNING

- Before charging, apply the Electronic Parking Brake (EPB) with the brake pedal pressed, shift to P (Park) and turn off the vehicle. Movement of the vehicle while charging may result in property damage, serious injury, or death.
- Use specified electric vehicle charger only. Failure to do so may damage the charger, charging cable, or vehicle. Also, it may lead to safety hazards, such as fire, explosion, etc.
- To avoid property damage, serious injury, or death from electric shock and fire, follow the instructions below:
 - Do not touch the charging connector, charging plug, or the charging inlet when connecting the cable to the charger and the charging inlet on the vehicle.
 - Do not touch the charging connector and charging plug with wet hands, or when standing in water or snow while connecting the charging cable.
 - When connecting or removing the charging cable, you must hold the charging connector handle and charging plug.
 - Use a waterproof charger. Do not charge the vehicle in a place where rainwater may come into contact with the joints of the charging cable connector and the charging plug.

- Ensure there is no water, dust, or other contaminants on the charging cable connector and the charging plug.
 - Immediately stop charging if you feel abnormal conditions, such as odor or smoke.
 - Do not charge the vehicle if there is a risk of lightning.
-

i Information

- While charging, the gear cannot be shifted from P (Park) to any other gear.
 - Ensure the vehicle door is unlocked before disconnecting the charging connector. The unlock button on the charging connector does not work when the vehicle door is locked.
 - To control the temperature of the high voltage battery while charging or when the battery temperature is high, the air conditioner is used to cool down the battery. It may generate noise or vibration from operation of the air conditioner compressor and cooling fan, but this is a normal condition when charging the high voltage battery.
 - The cooling system may be operated when using the air conditioner during charging. This may degrade the air conditioner's performance temporarily.
 - Depending on the condition and durability of the high voltage battery, charger specifications and condition, and ambient temperature, the time required for charging the battery and distance to empty may vary.
 - In rare cases, you might hear high-frequency noise (a small beeping sound) outside the car when charging with a 400 V DC charger that has deteriorated or has long communication delay. The high-frequency noise can be generated only when the vehicle tries to reduce its own electromagnetic waves to keep DC charging as stable as possible. Do not worry about this beep noise, because it is intentional and does not affect the charging performance or the vehicle itself.
-

Precautions for operating the cooling fan

WARNING



Do not put your hand near the cooling fan in the motor compartment while charging. It may operate automatically to control the battery temperature, even if the vehicle is turned off.

Precautions for operating the charging door

Before operating the charging door, carefully read and follow all the safety information below.

CAUTION

- Before opening the charging door, check the direction in which the door opens and ensure that there is no interference with nearby objects when opening or closing the door.
 - When opening and closing the charging door, be careful not to bump your face, head, etc., or get your hands or other body parts caught in the door.
 - For more information, refer to the "Electric charging door" section in chapter 5.
 - Do not try to forcibly open the charging door. It may cause damage to the charging door or cause a malfunction.
 - Do not hold the parts that support the charging door. Damage to parts or deformation of parts may cause vehicle damage and accidents.
-

Precautions for using, handling, and storing the charging cable

Precautions when using the charging cable

CAUTION

- To prevent electric shock, replace the charging cable if the coating or the connector is damaged.
 - Do not modify or disassemble the charging cable. Doing so may result in fire, electric shock, or injury.
 - Do not pull or twist the charging cable excessively, and ensure that the cable is not twisted. Power cuts or damage to the cable's insulation sheath may result in electric shock or fire.
 - Do not drag the charging cable on the floor or place objects on it. Damage to the insulation of the cable may result in electric shock or fire.
 - Do not use the charging cable near a heat source or heating appliance.
 - Do not drop or subject the charging cable to a strong impact. Also, ensure no water or liquid comes into contact with the cable.
 - Use the charging cable only when there are no children around.
 - If there is any sign of damage, corrosion, or rust on the charging connector and plug, or if the connection of the charging connector and plug feels loose, do not use the cable. We recommend that your vehicle be inspected by an authorized HYUNDAI dealer.
-

Precautions when handling and storing the charging cable

CAUTION

- Always keep the charging connector and plug dry and clean.
 - Ensure that the connectors, plugs, and control box (portable charger) of the charging cable are not submerged or in contact with water.
 - Keep the charging cable free from water or moisture, and keep it in the cargo area compartment.
 - Do not keep the charging cable near heat source or heating appliances.
 - Keep the charging cable away from children.
 - If there is dust or contaminants inside the charging connector or plug, remove it using the air gun.
 - If the charging cable is contaminated, completely disconnect the cable from the charger or power, and remove the contaminants.
 - Wipe the charging cable lightly with the soft cloth soaked with a 3 % neutral detergent aqueous solution, then use a clean cloth to completely remove moisture and dry the cable in a well-ventilated shade.
 - When removing contaminants, ensure the charging connector and charging plug are not in contact with water.
 - Do not use organic solvents, such as benzene, paint thinner, or detergent. Doing so may cause deformation, discoloration, or malfunction of charging cable.
 - When using a vehicle decontamination agent, ensure that the product does not contain organic solvents, such as benzene, paint thinner, or detergent.
-

Checking basic information on charging your electric vehicle

Before charging your vehicle, check and understand the information such as the estimated charging time according to the charge type, checking the State of Charge (SOC), and setting the charger lock mode.

Checking charge types and times

The charge types for electric vehicle are as follows:

- **AC charge:** The electric vehicle is charged via an AC charger at public charging stations. An AC charger may require an AC charging cable (sold separately).
- **DC charge:** You can charge at high speeds at public charging stations. Refer to the respective company's manual that is provided for each DC charger type.
- **Portable charge:** If the vehicle cannot be moved to a public charging station due to a lack of battery power, the vehicle can be charged with household electricity, using the 220 V/230 V portable charger (sold separately).

CAUTION

- Battery performance and life may deteriorate if the DC charger is used constantly. Use of DC charging should be minimized in order to help prolong high voltage battery life. Use AC charging unless DC charging is necessary.
 - The electrical outlet at home must comply with regulations and can safely accommodate the Voltage, Current (Amps), and Power (Watts) ratings specified on the portable charger. If not, the vehicle may not be charged or safety hazards, such as fire, may occur.
 - If the power distributor exceeds its capacity while charging the vehicle with a portable charger at home, the power to home may be cut off or a fire may occur.
 - If you use a portable charger to charge your electric vehicle with household electricity, you are charged on your household electricity bill.
-

The estimated charging time for each charging type is as follows:

Charging type		Charging time		Charge level (Minimum - Maximum)	Charging condition (Temperature)
		Standard battery	Long range battery, CROSS battery		
AC charge	230 V/16 A/3 phases	About 4 hours	About 4 hours 35 minutes	10-100 %	Battery temperature (25 °C)
	220 V/48 A	About 4 hours 15 minute	About 4 hours 45 minutes		
DC charge	150 kW	About 30 minutes	About 30 minutes	10-80 %	
	50 kW	About 55 minutes	About 55 minutes		
Portable charge	230 V/12 A	About 16 hours 55 minutes	About 19 hours 40 minutes	10-100 %	
	220 V/12 A	About 17 hours 45 minutes	About 20 hours 40 minutes		

i Information

- Depending on the condition and duration of use of the high voltage battery, charger specifications, and ambient temperature, the time required for charging the high voltage battery may vary.
- If the charger is worn out, exposed, or there exists any type of damage, charging may stop for your safety. Use another charger that works normally.
- When charging the battery, an additional 3 minutes may be required to check battery condition.

Checking the charging status

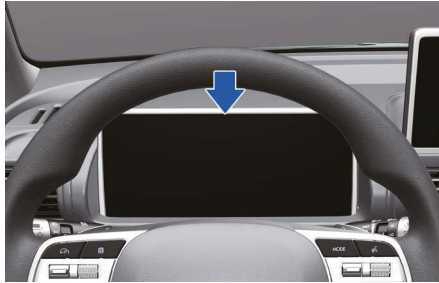

Check the charging state on the cluster display to monitor the battery capacity of the high voltage and estimated charging time.

When charging starts, the charging state will be displayed on the cluster display.

i Information

- With the vehicle on, the charging state will be displayed continuously.
- When the vehicle is off, the charging state will be displayed for up to 1 minute. The charging state will be displayed continuously when a door is opened.



Center of steering wheel

 If equipped

1. The charging light located on the center of steering wheel shows the total battery power remaining.
 - The charge level is divided into four levels, from 0 to 100 %.



Charge level indicator	Charge level
	0-24 %
	25-49 %

Charge level indicator	Charge level
	50-74 %
	75-100 %

Checking information on the charging label

Open the charging door and check the information on the charging label. The charging label shows safety symbols and the rated input specifications for charging.



No.	Name	Description
(1)	Warning for high voltage	Indicates a device with a risk of electric shock.
(2)	Warning/Caution symbol	Indicates a device that may cause property damage, serious injury or death if not operated carefully.
(3)	Rated voltage and maximum charging current	Indicates the type of input current (AC) and the rated voltage range (V) and charging current (A) when AC charging.

Setting charging connector locking mode

You can lock the charging connector during AC charging to prevent unintended detachment of the charging connector from the vehicle.

i Information

The connector is automatically locked during DC charging or while using the V2L function, regardless of the settings of charging connector locking mode applied to the vehicle.

- When DC charging is complete, the charging connector is unlocked automatically.
- After using electricity, you can unlock the charging connector by pressing the switch on the V2L connector to turn off the power and unlock the vehicle door.
- Select **User Settings > ECO Vehicle > Lock Charging Cable > Always/While charging/ Do not lock** in the instrument cluster or select **EV > ≡(MENU) > EV settings > Charging connector locking mode > Auto/ Lock/ Unlock** on the Home screen of the infotainment system, to set the locking mode of the charging connector.

The available locking mode options are as follows:

- **Always/Auto:** Locks the connector automatically whenever the charging connector is plugged into the charging inlet.
- **While charging/Lock:** Locks the connector automatically only while charging is in progress after the charging connector is properly connected to the vehicle.
- **Do not lock/Unlock:** The connector unlocks regardless of the state of charging. Press the charging connector release button, disconnect the connector. Be careful to theft of the charging cable.

Disconnecting the charging connector in an emergency

If the unlock button is not functioning properly due to a discharged battery or abnormal electrical wiring, the charging connector cannot be disconnected from the vehicle.

⚠ CAUTION

Do not disconnect the charging connector forcibly. Doing so may damage the charging connector or the charging inlet on the vehicle.

If the charging connector is not disconnected due to battery being fully discharged or a wiring failure, open the hood and pull the emergency cable.

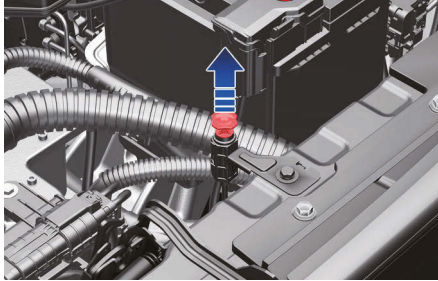

- If the charging connector does not disconnect after pulling the emergency cable, we recommend that your vehicle be inspected by an authorized HYUNDAI dealer.

Using an AC charger

AC charging is the most common charging method for electric vehicles. Charge your electric vehicle using an AC charging cable installed in public charging stations or separately purchased AC charging cable.

WARNING

Before charging the vehicle, carefully read and follow the instructions in "Safety precautions for charging your electric vehicle" to prevent property damage or injury due to electric shock, fire, explosion, etc.

CAUTION

To prevent property damage or injury due to fire or explosion, follow the instructions below.

- Only use the genuine AC charging cable provided by the manufacturer (if equipped).
- Do not use an extension cable.
- Check the rated voltage and maximum charging current required for charging, and ensure that the charger power you are using meets the requirements.
- Immediately stop charging if you discover abnormal conditions, such as odor or smoke.

Understanding the AC charging cable

The exterior and configuration of the AC charging cable are as follows:

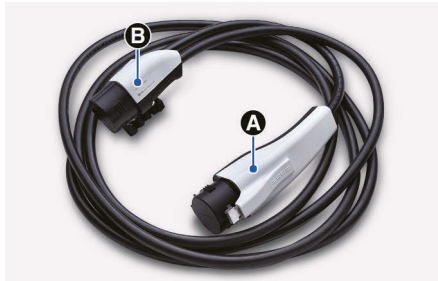

[A] Charging connector (Vehicle side)
[B] Charging plug (Charger side)

Charging with an AC charger

Follow the instructions below to charge the vehicle with an AC charger.

1. With the vehicle started, apply the Electronic Parking Brake (EPB) while pressing the brake pedal.
2. Turn all switches off, shift to P (Park), and turn off the vehicle.
3. With the door unlocked, open the charging door by pressing the sign of opening.
4. Open the charging inlet cover and check the charging connector and charging inlet for dust or other contaminants.
 - If there is any dirt or contaminants, remove it using the air gun.

⚠ WARNING

Do not touch the charging connector of the charging cable or the charging inlet on the vehicle.

5. Remove the charging connector protection cap of the AC charging cable, hold the charging connector handle, and connect it to the AC charging inlet on the vehicle. Push it until you hear a click.
6. **[If using separately purchased charging cable]** Remove the charging plug protection cap of the AC charging cable, hold the charging plug handle, and connect it to the electric outlet (220 V/230 V) of the AC charger.
 - This process is required only when using a separately purchased AC charging cable. If you use a charging cable installed in an AC charger, a separate charging plug connection is not required.

i Information

- When scheduled charging is set, "**Waiting to charge at scheduled time**" is displayed.
 - When scheduled air conditioner or heater operates while waiting for the scheduled charging, the estimated charging time is displayed as "-."
-

7. **[If using a separately purchased charging cable]** When charging is complete, hold the charging plug handle, disconnect the charging plug from the electric outlet (220 V/230 V) of the AC charger, and close the protection cap of the charging plug.
- This process is required only when using an AC charging cable purchased separately. If you use a charging cable installed in an AC charger, a separate charging plug disconnection is not required.
8. Hold the charging connector handle, and pull the charging connector to disconnect it from the charging inlet.

CAUTION

Do not forcibly disconnect the charging connector without pressing the unlock button on the charging connector. It may damage the charging connector or the charging inlet on the vehicle.

9. Close the charging inlet cover and press the charging door to completely close it.

Information

- If the charging connector locking mode is set to **Always** or **While charging**, unlock the door by pressing the button on the smart key or the button on the driver's door, and disconnect the charging connector from the charging inlet.
 - For more information, refer to the "Setting charging connector locking mode" section in this chapter.
 - During AC charging, the quality of radio reception may degrade in some areas.
-

Using a DC charger

If you need to charge the vehicle in a short time, you can charge at high speeds using a DC charger installed in public charging stations.

WARNING

Before charging the vehicle, carefully read and follow the instructions in "Safety precautions for charging your electric vehicle" to prevent property damage or injury due to electric shock, fire, explosion, etc.

CAUTION

Battery performance and life may deteriorate if the DC charger is used constantly. Use of DC charging should be minimized in order to help prolong high voltage battery life. Use AC charging unless DC charging is necessary.

Understanding the DC charging connector

The exterior of the DC charging cable is as follows:

Type A



Type B



Charging with a DC charger

Follow the instructions below to charge the vehicle with a DC charger.

1. With the vehicle started, apply the Electronic Parking Brake (EPB) while pressing the brake pedal.
2. Turn all switches off, shift to P (Park), and turn off the vehicle.
3. With the door unlocked, open the charging door by pressing the sign of opening.
4. Open the charging inlet cover and check the charging connector and charging inlet for dust or other contaminants.
 - If there is any dirt or contaminants, remove it using the air gun.

⚠ WARNING

Do not touch the charging connector of the charging cable or the charging inlet on the vehicle.

5. Remove the charging connector protection cap of the DC charging cable, hold the charging connector handle, and connect it to the DC charging inlet on the vehicle. Push it until you hear a click.

6. When charging is complete, hold the charging connector handle and pull out the charging connector to disconnect it from the charging inlet.
 - Depending on the DC charger types, some DC chargers may not have a charger connector unlock button.

CAUTION

Before disconnecting the charging connector, check if there is an unlock button on the connector handle. If the connector handle is equipped with an unlock button, forcibly disconnecting the connector without pressing the button may damage the charging connector or charging inlet on the vehicle.

NOTICE

For more information, refer to the "Setting charging connector locking mode" section in this chapter.

7. Close the charging inlet cover.
8. Press the charging door to completely close it.

Information

During DC charging, the quality of radio reception may degrade in some areas.

Using a portable charger (ICCB)

If the vehicle cannot be moved to a public charging station, you can charge the vehicle using a separately purchased In-Cable Control Box (ICCB) in places where general power (AC 220 V/230 V) is supplied.

WARNING

Before charging the vehicle, carefully read and follow the instructions in "Safety precautions for charging your electric vehicle" to prevent property damage or injury due to electric shock, fire, explosion, etc.

CAUTION

To prevent property damage or injury due to fire or explosion, follow the instructions below.

- Only use a genuine HYUNDAI portable charger (if equipped).
- Do not let children operate or touch the portable charger. Doing so may lead to unexpected accidents.
- Do not use an extension cable.
- The charger power you are using must comply with regulations and safely accommodate the voltage, current (amps), and power (watts) ratings. If not, the vehicle may not be charged or safety hazards, such as fire, may occur.

- If the power distributor exceeds its capacity while charging the vehicle with a portable charger at home, the power to the home may be cut off or a fire may occur.
- Immediately stop charging if you discover abnormal conditions, such as odor or smoke.
- Use a portable charger only in emergencies, and do not use it to fully charge the battery.
- If you charge the vehicle with household electricity, you are charged electricity bill according to the home rate system, not the electric vehicle rate system.

Understanding portable chargers

The configuration of a portable charger and the display of the operation indicator are as follows:

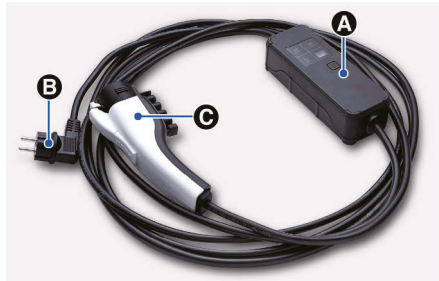

- [A] Control box
- [B] Power plug
- [C] Charging connector

Icon	Name	Color	Description
	READY	Green	Turns on when the power is on.
	CHARGE	Blue	Turns on while charging and blinks when current is limited (Forcibly switched to 6 A).
	FAULT	Red	Blinks when a leakage current, communication error, or overcurrent error occurs, or when the high-temperature protection inside the plug and charger is activated.
	CHARGE LEVEL	-	Displays the present charging current setting (6 A, 8 A, 10 A, or 12 A).

Icon	Name		Color	Description
	E1	Control pilot communication	-	Vehicle communication error
	E2	Leakage	-	Current leakage
	E3		-	Charger error
	E4	Plug temperature	-	Plug overtemperature warning
	E5		-	Plug temperature failure
	E6		-	Charger error
	E7	Overcurrent	-	Charging overcurrent warning
	E8	Internal temperature	-	Charger overheating
	E9		-	Charger error
	F1	Relay fusion	-	Charger error
	F2	Ground Monitoring/ Interrupt	-	Poor grounding of outlet
	F3	Switched mode power supply power failure	-	Switched mode power supply error (voltage failure)
	F4		-	Switched mode power supply error (abnormal voltage)
	F5	Control Pilot voltage error	-	Control Pilot (-) voltage error
	F6		-	Control Pilot (+) voltage error
F7	Temperature sensor error	-	Plug temperature sensor error	
F8		-	PCB internal temperature sensor error	

- If an error occurs, you can reset the portable charger by disconnecting and reconnecting the power plug, and then pressing the button on the control box for more than 2 seconds.
- If the same symptom repeats after resetting the portable charger, we recommend that your vehicle be inspected by an authorized HYUNDAI dealer.
- If there is no status change for more than 1 minute, the portable charger is switched to power saving mode, and the display light is turned off.

Charging with a portable charger

Follow the instructions below to charge the vehicle with a portable charger.

1. Connect the power plug of the portable charger to the electrical outlet at your home.
 - The power indicator light on the control box turns green.
2. Set the charging current by pressing the button on the control box for more than 2 seconds until the number on the charging current indicator blinks.

NOTICE

An example of a portable charger charging current setting suitable for the rated current of the power supplied is as follows. However, the appropriate charging current may vary depending on the environment, such as the power usage inside the building.

Outlet current	ICCB charge level
14-16 A	12 A
12-13 A	10 A
10-11 A	8 A
8-9 A	6 A

- The charging current is changed each time the button is pressed, in the order of '6 A - 8 A - 10 A - 12 A'.
- If 10 seconds have passed without pressing any button, the blinking stops and the charging current setting is finished.

3. With the vehicle on, apply the Electronic Parking Brake (EPB) while pressing the brake pedal.
4. Turn all switches off, shift to P (Park), and turn off the vehicle.
5. With the door unlocked, open the charging door by pressing the sign of opening.
6. Open the charging inlet cover and check the charging connector and charging inlet for dust or other contaminants.
 - If there is any dirt or contaminants, remove it using the air gun.

WARNING

Do not touch the charging connector of the charging cable or the charging inlet of the vehicle.

7. Remove the charging connector protection cap of the portable charging cable, hold the charging connector handle, and connect it to the AC charging inlet of the vehicle. Push it until you hear a click.

i Information

- When scheduled charging is set, "**Waiting to charge at scheduled time**" is displayed.
- When scheduled air conditioner or heater operates while waiting for the scheduled charging, the estimated charging time is displayed as '-'.

8. When charging is complete, hold the charging connector handle with the unlock button pressed and pull on the charging connector to disconnect it from the charging inlet.

i Information

If you have set the charging connector locking mode as **Always** or **While charging**, unlock the door by pressing the button on the smart key or the button on the driver's door, and disconnect the charging connector from the charging inlet.

- For more information, refer to the "Setting charging connector locking mode" section in this chapter.

9. Close the charging inlet cover.

10. Press the charging door to completely close it.

i Information

During portable charging, the quality of radio reception may degrade in some areas.

Using the scheduled charging function

The scheduled charging function allows you to charge your vehicle using low-cost, late-night power until the next departure time.

i Information

You can use the scheduled charging function only when using an AC charger or the portable charger (ICCB: In-Cable Control Box). For more information about connecting an AC charger and portable charger, refer to the "Using an AC charger" and "Using a portable charger (ICCB)" section in this chapter.

On the Home screen of the infotainment system, select **EV > Scheduled charging and target temperature**.

- For more information, refer to the "Setting the charging and climate" section in this chapter.
- When scheduled charging is set and the AC charger or the portable charger (ICCB) is connected for charging, the indicator lamp gradually illuminates for 3 minutes to indicate that scheduled charging is set.
- When scheduled charging is set, charging is not started immediately when the AC charger or portable charger (ICCB) is connected. To charge the vehicle immediately, select **EV > Scheduled charging and target temperature** on the screen and deactivate the scheduled charge setting.

i Information

Charging may start immediately after a charger is connected to the vehicle, depending on the charging time calculated when setting up the scheduled charging.

Checklist when charging does not start

Check the following if charging does not start after connecting the charger to the vehicle.

- Check the scheduled charging setting. If the scheduled charging is set, charging is not started after connecting an AC charger or portable charger to the vehicle until the setting conditions are met.
- Check the operation status of the AC charger, DC charger, and portable charger. Actual method for indicating the operation status may vary in accordance with the charger manufacturer.
- If a warning sign related to charging appears on the instrument cluster, check its message.
- If the charging connector and charging inlet are not connected properly, the connector may droop or vibrate. In this case, hold the charging connector handle and push it all the way in.
- Check the charging status by connecting another charger that has been approved for proper operation.
 - If the vehicle is charged normally using another charger, contact the charger manufacturer for a solution.
 - If the vehicle is not charged even when using another charger, we recommend that your vehicle be inspected by an authorized HYUNDAI dealer.

Using Electric Vehicle functions

EV(Electric vehicle) provides driving information and high voltage battery information. You can set various electric vehicle functions in **EV(Electric vehicle)**.

Checking the Electric Vehicle screen configuration



Follow the instruction below to enter EV(Electric vehicle) mode and check the screen configuration.

1. On the infotainment screen, move to Home screen and select **EV**.
2. The **Electric vehicle** mode screen appears.

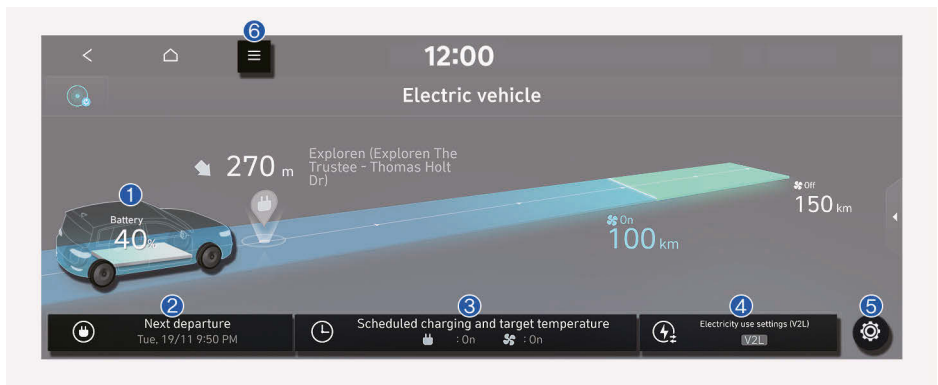
The details of the **Electric vehicle** mode screen is as follows:



No.	Name	Description
(1)	Energy information	You can check the energy consumption and energy economy history.
(2)	Next departure	You can set a scheduled departure time by which charging is complete and the cabin temperature is preconditioned.
(3)	Scheduled charging and target temperature	You can set the date and time of when to charge the battery and the climate control temperature.
(4)	V2L	You can set the battery discharging limit(%) for the high voltage battery for driving. For more information, refer to the "Setting a battery discharging limit when using Vehicle to Load (V2L)" section in this chapter.

No.	Name	Description
(5)		You can set various electric vehicle specialized functions. <ul style="list-style-type: none">• Battery conditioning• Utility mode For more information, refer to the "Setting electric vehicle specialized functions" section in this chapter.
(6)	 (Menu)	You can turn off the screen and check the energy information.

Checking energy information

You can check the energy consumption and energy economy history.

1. On the infotainment screen, move to Home screen and select **EV**.
2. Check the **Energy information**.



Checking the energy consumption

On the infotainment screen, select **Energy information**.

- You can check the current energy consumption for each vehicle system.

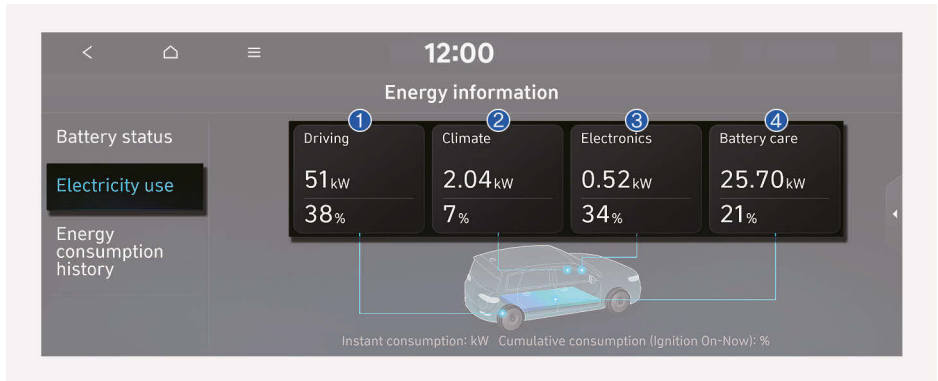

No.	Name	Description
(1)	Driving	Shows the percentage of instantaneous and regenerative energy consumed by the motor to drive the vehicle and the percentage of the power driving system used in total power used since starting the vehicle.
(2)	Climate	Shows the power and energy consumption used by the air conditioner or heater and the percentage of the power climate system used in total power used since starting the vehicle.
(3)	Electronics	Shows the power and energy consumption used by the vehicle system, including the instrument cluster, infotainment system (speaker and navigation), headlight, vehicle control unit, etc., and the percentage of the power vehicle system used in total power used since starting the vehicle.
(4)	Battery care	Shows the momentary power and energy consumption used when increasing and cooling down the battery temperature to maintain optimal battery performance and the percentage of battery temperature control mode (Battery Care mode) used in the total power used since starting the vehicle.

Setting the next departure time

You can set an anticipated departure time for scheduled charging and target temperature.

i Information

Scheduled charging and climate is activated based on the departure time.

1. On the infotainment screen, move to Home screen and select **Electric vehicle** > **Next departure**.
2. Set the anticipated departure schedule.

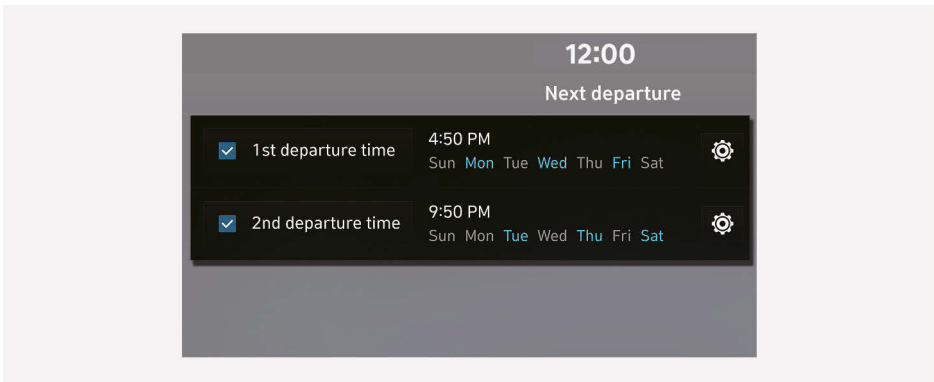

3. Set anticipated departure time (1) and select the day of the week (2).

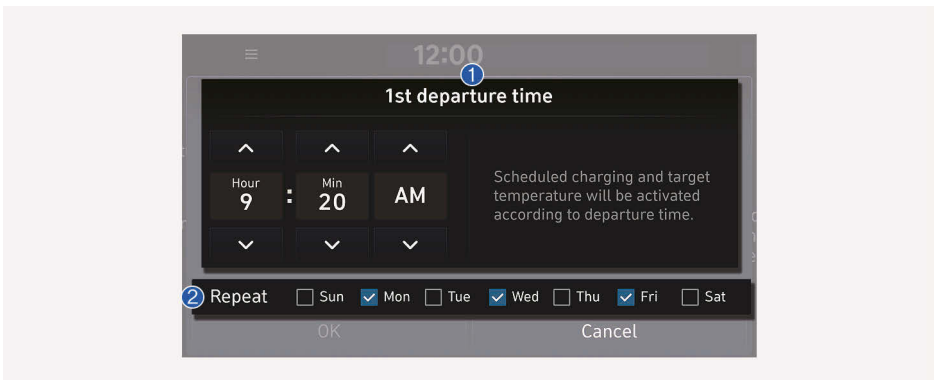

4. Scheduled charging and climate is activated based on the departure time.

Setting the charging and climate

i Information

- Vehicle must be connected with the charging connector at the pre-scheduled time for the scheduled charging and climate.
- The scheduled climate function directly uses the power of the connected charger. It can maintain a pleasant environment and enhance vehicle performance by controlling the temperature of the vehicle and the battery without using the high voltage battery power.

1. On the infotainment screen, move to Home screen and select **Electric vehicle > Scheduled charging and target temperature**.

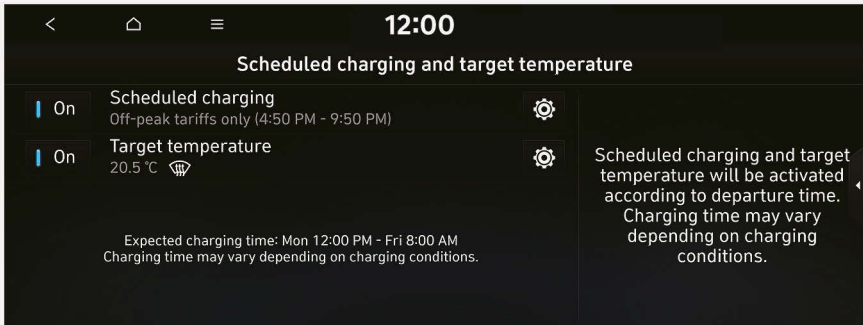

You can set the date and time of when to charge the battery and the climate control temperature. Also, you may select the time to start charging using the off-peak time setting.

2. Off-peak time settings

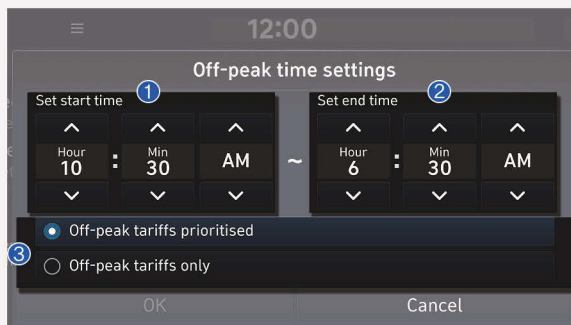

- **Set start time (1):** If selected, starts charging only on the designated off-peak time.

- **Set end time (2):** If selected, sets the most inexpensive time to complete charging.
 - You may select (3):
 - **Off-peak tariffs prioritised:** Charging is activated during the off-peak time. It may keep on charging pass off-peak time to reach the target battery charge level.
 - **Off-peak tariffs only:** Charging is activated only during the off-peak time. It may not be able to reach the target battery charge level.
3. Target temperature settings
4. Scheduled climate is activated based on the departure time.
- The scheduled climate operates 20 minutes before and 10 minutes after the departure.
 - **1st departure time (1):** Enter the time of departure.
 - **Repeat (2):** Designate the date you want to repeat.
 - **Target temperature settings (3):** Enter the desired temperature.

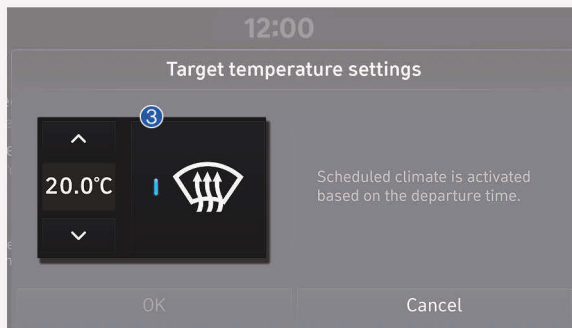
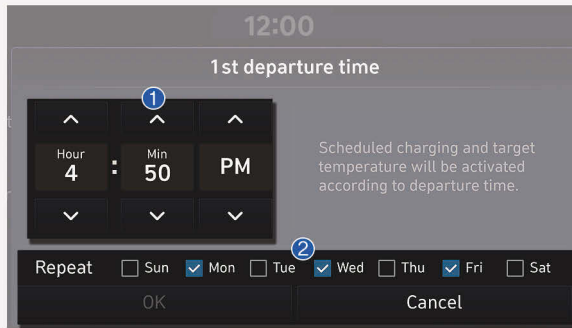

In cold weather, pre-scheduled heating helps enhance electric vehicle performance by heating the vehicle in advance.

Setting a battery discharging limit when using Vehicle to Load (V2L)

Setting battery discharging limit (%) can prevent the battery from discharging when operating home appliances or electronic devices using the high voltage battery.

- For more information about V2L function, refer to the "Using V2L function" section in this chapter.

i Information

V2L is the system provides AC power using the high voltage battery for driving to operate several electronic devices. You can operate home appliances and electronic devices, or charge another electric vehicle in emergency using the charged electricity from the vehicle's battery while camping or doing other outdoor activities.

1. On the infotainment screen, move to Home screen and select **Electric vehicle** > **V2L**.
2. Set the desired battery discharging limit (%).
 - The battery discharging limit can only be set below the current battery charge.
 - When the battery charge reaches the set battery discharging limit, V2L function cuts off automatically.

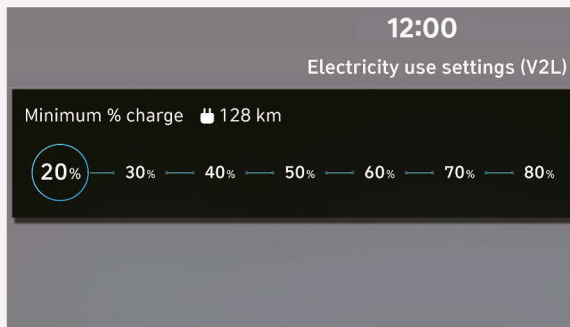

Setting electric vehicle specialized functions

You can set various EV specialized functions such as battery conditioning mode and utility mode.

Setting the target battery charge level

You can set the target battery charge level when charged with an AC charger or a DC charger.

- You can check the status of high voltage battery, estimated distance to empty, and the time required for charging the target battery level.

i Information

- The distance to empty is estimated based on the energy economy and temperatures. It may vary according to your driving style.
- The distance to empty may vary even with the same target level according to changes of your driving style.

1. On the infotainment screen, move to Home screen and select **Electric vehicle > EV settings**.
2. Set each of the target battery charge level for AC charger and DC charger.
 - The charging level can be changed by 10 %.
 - If the target battery charge level is lower than the current high voltage battery charge level, the battery is not charged.

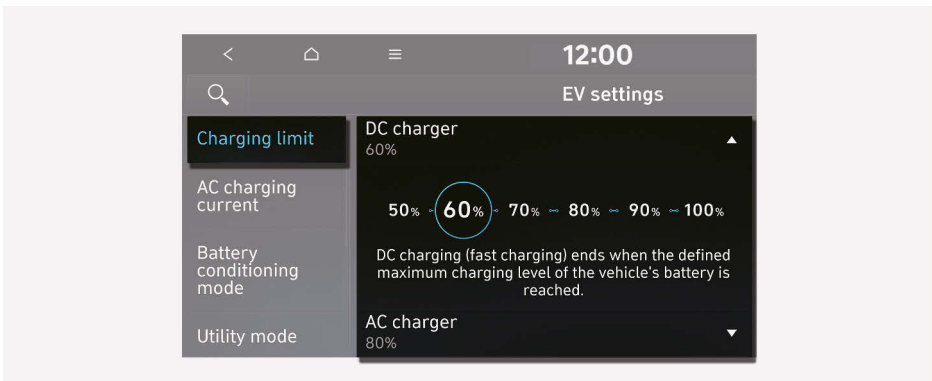

i Information

- The use of regenerative brakes is limited when the high voltage battery is fully charged. This can cause overheating or temporary breakdown of brakes when you drive on a steep or long downhill road. Make sure to charge the battery amount below 90 % when driving in a high-altitude area.
- The recommended battery charge amount when driving in a high-altitude area is displayed on the infotainment system.

Using Battery Conditioning

If the temperature of the high voltage battery is low and there is a concern that the charging and discharging performance of the battery may be deteriorated, the battery conditioning function can be used to secure the battery temperature suitable for fast charging and driving performance in conjunction with the navigation system.

When the fast charging station is set as a destination or a stopover in the navigation system, the battery conditioning function is operated to ensure an appropriate battery temperature according to the arrival time of the set fast charging station.

On the infotainment screen, move to Home screen and select **EV > Battery conditioning mode** to set the function.

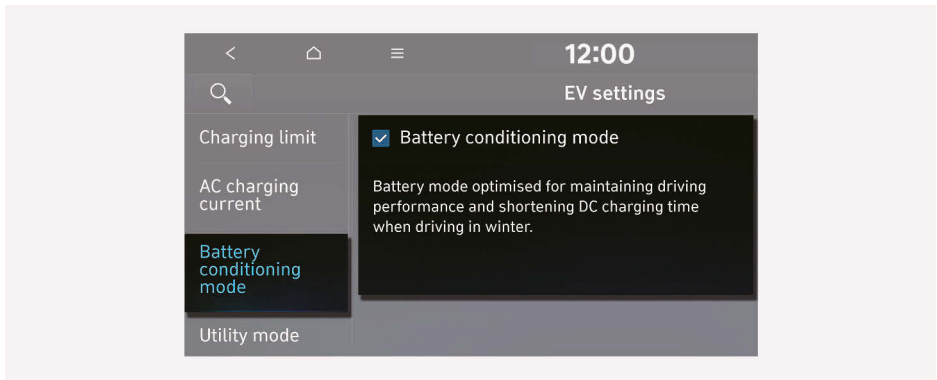

i Information

- Battery Conditioning function operates only in a vehicle equipped with a battery heater.
- Battery Conditioning function does not operate to ensure driving distance when the battery charge level is low. The function also does not operate if the temperature of the battery is ideal for driving and charging.
- The charged power used to raise the temperature of a battery may shorten the driving distance. Reaching the optimal temperature of a battery requires time.
- When you are a member of Bluelink, you can control the battery Conditioning function remotely while parking from the Bluelink app. For more information on Bluelink, refer to the separately supplied manual.
- The indicator light turns on to show that the battery conditioning is operating.

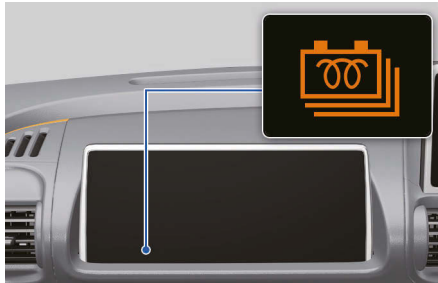

Setting Utility mode

Utility mode allows the high voltage battery to be used instead of the 12 V battery for purposes other than driving. You can use the audio and lights of the vehicle without worrying about discharging the battery and even use the indoor V2L feature.

i Information

- You cannot drive the vehicle while the utility mode is activated, and the gear can only be shifted to P (Park).
 - You can use every electric device in the vehicle while the utility mode is activated.
 - When the utility mode is activated, the Electronic Parking Brake (EPB) is applied automatically and you can release EPB by pressing the EPB switch if necessary.
-

Follow the instructions below to set the utility mode.

1. Check the operation conditions of the utility mode.
 - Check if the **READY** indicator is displayed on the instrument cluster.
 - Check if the reducer is shifted to P (Park).
2. On the infotainment screen, move to Home screen and select **EV > Utility mode**, and then select **Activate utility mode** to activate the function (Utility mode: ON).

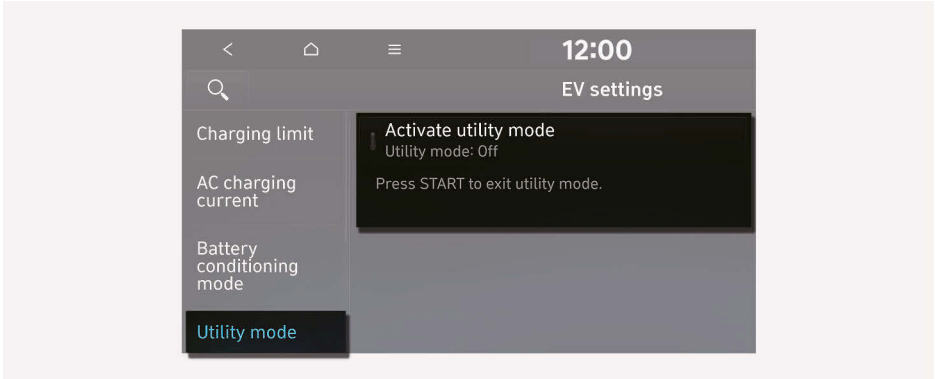

- The **READY** indicator turns off and the **UTIL** indicator illuminates on the instrument cluster and the EPB is applied.
- The utility mode can be deactivated by pressing the Start/Stop button to the OFF position.
- If you want to utilize the V2L feature in the vehicle while the utility mode is activated, refer to the "Using electricity inside the vehicle" in this chapter.

i Information

If the utility mode is not activated when the vehicle is in the ready mode (**READY** indicator ON) and the gear is shifted to P (Park), inspect the operation status of EPB.

Using V2L function

With the Vehicle to Load (V2L) feature, you can turn on electronic devices by connecting them to the high voltage battery.

Safety precautions when using the V2L function

Before using V2L function, carefully read all the safety information below and follow precisely. Failure to do so may cause electric shock or fire and result in a serious injury, death, malfunction in your vehicle or property damage.

Precautions when using the V2L function

WARNING

- Do not use the V2L function if the V2L connector, charging inlet, power plug, or cable is damaged, corroded, or rusted.
- Do not touch the V2L connector, charging inlet, or power plug with wet hands.
- Do not use the V2L function if the connection part of the V2L connector and the charging inlet is loose.
- Check if there is no water, dust, or other contaminants before connecting the connector and the plug. They may cause electric shock or fire.
- Do not put metal objects or bare hands to the V2L connector or charging inlet.
- For electric devices used outdoors in a vehicle, use a product with a waterproof function or use it in a waterproof environment. If rain or humidity intrude into electric devices, multi-outlets, extension cords, etc., it may cause electric shock or damage to the vehicle or the devices.
- If there is a risk of lightning, do not use the V2L function outside the vehicle.
- Do not use an electric heating appliances like electric kettle, toaster, or iron in the vehicle. Doing so may result in a fire and injury.

Precautions for operating the cooling fan

WARNING



When using the V2L, the cooling fan in the vehicle motor compartment can operate automatically even if the vehicle is turned off. Do not put your hand near the cooling fan in the V2L operating state.

Precautions for handling and using the V2L connector

⚠ CAUTION

- Do not remodel or disassemble the V2L connector. It may cause fire, electric shock, or injury. Damage to your vehicle caused by remodeling and disassembling is not covered by warranty.
 - When the power plug is connected or disconnected to the V2L connector or open or close the connector cover of the V2L, be careful not to be scratched on the hand or other parts of the body.
 - Be sure to disconnect the V2L connector from the vehicle when you are finished using V2L.
 - Do not charge the vehicle using the V2L connector. If you charge the vehicle arbitrarily by remodeling the power cable of the connector, etc., it may damage the vehicle.
 - Do not place objects on the V2L connector. It may damage the cable and cause electric shock or fire.
 - Do not drop the V2L connector or give a strong impact to it. Keep it clean in a dry place without water or humidity.
-

Precautions when using electric/electronic products

⚠ CAUTION

- Before using the product, check the precautions and how to use the product referring to the product manual.
- Only use products that have obtained national safety certification.
- Only use an electric device that does not exceed the maximum power capacity that the vehicle can supply. However, some of the electric devices may not operate normally even if the product has power consumption less than the maximum power capacity provided by the vehicle.
 - Electric devices that require high power during initial operation.
 - Measuring devices that need to process accurate data.
 - Electric devices that are sensitive to inverter type AC charger.
- Do not use products that require a continuous power supply, such as medical equipment. The power supply may be interrupted depending on the vehicle's condition.
- The V2L discharging mode is blocked automatically in case of overheating. When the discharging mode is blocked, check whether the V2L connector or power plug is contaminated, worn, corroded or broken.
 - If the temperature falls to a proper level after it is left unattended, you can use it again.
 - If overheating repeats when using a certain electric device, do not use the electric device.

- Do not connect more than two extension cords or multi-outlet. Also, when using the extension cable, ensure using the cable without twist. Heat from the overlapped cable may cause fire.
 - Do not hang the home appliances onto the wire.
 - Do not use if the sheath of home appliance cables is damaged or broken.
 - Put the power plug fully when connecting to the power.
 - Only use the qualified plug with ground connection that meets the standard. Do not use worn, corroded, or broken plug or improper plug that does not meet the standard.
-

Using electricity outside the vehicle

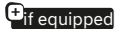
 if equipped

Before using V2L function, carefully read all the safety information and precautions on "Safety precautions when using the V2L function" and follow the instructions.

Follow the instructions below to connect the V2L connector to the charging inlet on the vehicle and supply power to an electronic product.

1. Open the cover of the V2L connector.
2. Close the cover after connecting the plug of an electronic product to the power outlet of the connector.

WARNING

Some types of plugs may not fit into the outlet cover of the V2L connector, causing incomplete closing of the cover. Do not use the V2L connector on a rainy or snowy day if the outlet cover is not completely closed. There is a risk of fire and/or injury.

3. Open the connection terminal protection cap of the connector with the open switch pressed.
4. Open the charging door and connect the V2L connector to the charging inlet on the vehicle.
 - Connect the V2L connector to the charging inlet within 60 seconds after opening the charging door.
 - Time remaining until the battery level reaches the set value, and the distance to empty at the set value appears on the instrument cluster or the infotainment system.
5. Press the power switch of the V2L connector.
 - The power is supplied and the indicator on the V2L connector is turned on.

i Information

- When the V2L connector is connected to the charging inlet of the vehicle, all doors and connectors will be automatically locked to prevent theft and separation. To disconnect the V2L connector, unlock the door and pull the connector with the open switch pressed.
- Before using the V2L function, deactivate the scheduled climate setting referring to the "Setting the charging and climate". The V2L function may be cut off depending on the scheduled climate setting.
- To check and change the V2L setting, refer to the "Setting a battery discharging limit when using Vehicle to Load (V2L)" section in this chapter.
- If an electric device that exceeds the maximum power capacity is connected, a warning message appears on the instrument cluster and the power supply shuts off immediately.

Using electricity inside the vehicle

 if equipped

You can connect home appliances or electric devices to the power outlet inside the vehicle and use them conveniently.

WARNING

Do not use an electric heating appliances like electric kettle, toaster, or iron in the vehicle. It may cause a fire and injury.

1. Press the Start/Stop button to the ON position or activate the **Utility mode**.
 - For more information about the **Utility mode**, refer to the "Setting Utility mode" in this chapter.



2. Open the power outlet cover by sliding it to the left, and connect the power plug of the electric device to the power socket.
 - Time remaining until the battery level reaches the set value, and the distance to empty at the set value appears on the instrument cluster or the infotainment system.

i Information

- The indicator on the power outlet indicates power supply status.



Indicator status	Description
Blue	Standby
Red	No power supply even the power outlet is connected.
Green	Normal power supply through the normal connection of the power outlet.

- V2L discharging mode shuts off if the vehicle is off using indoor V2L on the vehicle state of ON.
- Opening the charging door or connecting the V2L connector to the charging inlet, the V2L discharging mode shuts off.
- If you want to use the indoor and outdoor V2L simultaneously, firstly connect the V2L connector to the charging inlet and use the indoor V2L.
- When the high voltage battery charge level reaches the set discharging limit (%), the operation stops, and a warning message appears on the instrument cluster. If you want V2L operation, set the discharging limit (%) lower than the current battery charge.
 - For more information about the discharging limit, refer to the "Setting a battery discharging limit when using Vehicle to Load (V2L)" section in this chapter.
 - For more information about warnings, refer to the "Checking the warning and indicator lights" section in this chapter.

Solving V2L problems

If a problem occurs while using the V2L function, the V2L stops and a related messages appears on the instrument cluster.

Check the cause of the message and take an appropriate measure referring to the table below.

Message	Cause	Measure
V2L finished. Defined charge level reached	The high voltage battery level reaches the discharging limit set level.	To use the V2L continuously, make the discharging limit set level lower than the present battery level. (Refer to the "Setting a battery discharging limit when using Vehicle to Load (V2L)" section in this chapter.)
Energy consumption too high. V2L cancelled	An electrical appliance that exceeds the maximum power output the vehicle can supply is connected.	Check the total power consumption of the electrical appliance and replace it a product within the V2L maximum power output.
V2L conditions not met	V2L is stopped for the following reasons: <ul style="list-style-type: none"> • V2L connector switch off • V2L connector overheating • Opening the charging door while using the V2L indoor outlet 	Make sure there are no problems with the V2L connector and the vehicle indoor outlet.

Aux. Battery Saver+

WARNING

When the function is activating the indicator lamp illuminates and high voltage electricity flows into the vehicle. Follow the instruction below to prevent electrical shock or injuries.

- Do not touch the high voltage electric wire (orange), connector, and all electric components and devices.
 - Do not modify or disconnect any electronic devices in your vehicle.
-

The Aux. Battery Saver+ is a function that specialized in battery protection, prevents the failure due to fully discharge of the 12 V battery.

If the user drives or charges the vehicle, the Aux. Battery Saver+ is automatically activated to check the 12 V battery charging state. If necessary, the high voltage battery charges the 12 V battery.

CAUTION

The Aux. Battery Saver+ function cannot prevent the 12 V battery discharging in the following situations:

- The 12 V battery is damaged or worn out.
 - The 12 V battery is used as a power supply or unauthorized electronic devices are used.
-

Information

- If the Aux. Battery Saver+ function was activated, the high voltage battery level may have decreased.
 - Depending on the condition of the vehicle or high voltage battery, the Aux. Battery Saver+ function may not operate normally or stopped.
-

Driving your electric vehicle

Check how to use the devices inside the vehicle that you must know for driving, such as starting, braking, and shifting the electric vehicle.

Starting and stopping the vehicle

Follow the instructions below to start or stop the vehicle.

CAUTION

- Always fasten the seat belt before starting the vehicle for safety.
- Check if the Electronic Parking Brake (EPB) is applied before starting the vehicle.

Starting the vehicle

1. Holding the smart key, sit in the driver's seat.
2. Press the Start/Stop button while pressing the brake pedal.
 - On the instrument cluster, READY indicator is displayed.

Information

While the READY indicator is displayed, press the brake pedal, shift to D (Drive) or R (Reverse), and release the EPB and the brake pedal to start moving the vehicle forward or backward. You can start driving by pressing the accelerator pedal slowly and decelerate or stop by pressing the brake pedal.

Stopping the vehicle

1. Stop the vehicle completely by pressing the brake pedal.
2. Apply the EPB while pressing the brake pedal, and press the reduction gear's P button to shift to P (Park).
3. Press the Start/Stop button.
 - The READY indicator on the instrument cluster turns off.

Information

There are other Start/Stop button positions besides the ON/OFF. Use it appropriately paying attention to the discharging of the 12 V battery.

- **ACC:** The 12 V battery power is turned on, allowing some devices, such as infotainment system and air conditioning system to operate. Press the Start/Stop button when it is in the OFF position to turn on ACC.
- **ON:** The 12 V battery power is turned on, allowing to check the instrument cluster and use all the electric devices inside the vehicle. Press the Start/Stop button when it is in the ACC position to turn it ON.

Understanding virtual engine sound system

Electric vehicles do not use an internal combustion engine, so there is no engine noise while driving. The Virtual Engine Sound System (VESS) generates engine sound to make pedestrians aware of the approaching vehicle when driving.

- If the vehicle is in the ready mode (READY indicator ON) and the gear is not in P (Park), the VESS is operated.
- When the gear is shifted to R (Reverse), an additional warning sound is heard.

⚠ CAUTION

- Be aware that the vehicle does not make engine noise while driving.
- Pay attention to the surrounding environment and drive carefully.
- After parking or waiting for a traffic light, please check around for children, or other obstacles before departure.
- When reversing, check directly behind you before driving. Pedestrians may not be able to recognize vehicle sounds.

Checking electric vehicle driving information

During vehicle operation, the instrument cluster displays the main information, such as distance to empty, real-time energy status, battery charge level, and warning messages, via the user interface and indicators.

Factors affecting the distance to empty

The distance to empty refers to the distance that can be driven by the current charged battery level and is displayed on the bottom of the instrument cluster while driving the electric vehicle.

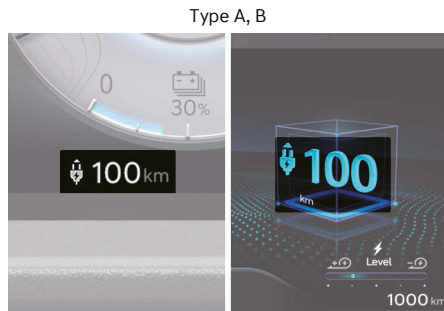

The distance to empty vary depending on many factors such as driving habits, power usage, driving conditions, and high voltage battery. The distance to empty may be increased or decreased than the certified figures as it reflects all the factors comprehensively. Check the distance to empty considering the following:

- The driving habits: The driving speed and tendency of accelerating and decelerating. High-speed driving or frequent accelerating and decelerating reduces the distance to empty.

- The power usage: Additional power use, such as the air conditioner, heater, lamps, etc. As the power usage increases, the distance to empty reduces.
- The driving conditions: The weather, temperature, and terrain. If you drive in snow/rain/strong wind or low temperature, the distance to empty will be reduced. The distance to empty will also be reduced when driving uphill or on slippery or rough roads.
- The electric energy: Proportional to the State of Charge (SOC), but may vary depending on the battery temperature and the State of Health (SOH) of a battery.

Change in the distance to empty when 100 % charged

In case the distance to empty has been reduced due to learning of the driving habit or the driving conditions, you can increase the distance to empty again by continuously driving following the "Tips for enhancing the distance to empty".

- Resetting the previously learned driving patterns at the service center may increase the distance to empty displayed on the bottom of the instrument cluster, but it does not increase the actual distance to empty. The distance to empty may not be accurate until the learning proceeds.
- If the high voltage battery temperature is low in winter, the distance to empty reduces but it is not a permanent change. The distance to empty may increase again once the temperature rises.
- If you reduce the power usage, the distance to empty may increase.
- Natural degradation may occur with the high voltage battery depending on the number of years the vehicle is used. This may reduce the distance to empty.

When setting a destination

When the destination is set, the distance to empty may change because the distance to empty is recalculated using the information of the destination instead of the learned electric energy economy history.

***i* Information**

The distance to empty may vary significantly based on traffic conditions or driving speed.

Tips for enhancing the distance to empty

The distance to empty vary depending on the charge level of the high voltage battery, weather, temperature, duration of the battery use, terrain, driving habits, etc.

You can increase the distance to empty by driving the vehicle following the instructions below.

- The air resistance increases rapidly as the electric vehicle drives faster, so avoid speeding to increase the distance to empty and the electric energy economy.
- Rapid acceleration consumes a lot of driving energy and rapid deceleration limits the regenerative braking. Gradually depress and release the accelerator pedal when accelerating or decelerating to maintain speed.
- If you operate the air conditioner or heater too much, the high voltage battery uses excessive electricity. This may reduce the distance to empty. Therefore, set the cabin temperature to 22 °C (71.6 °F) AUTO level 2. Especially in winter, reducing heating and using heated seats instead can significantly increase the distance to empty. Turn off the air conditioner or heater if you do not need them.
- When using the air conditioner or heater, the energy consumption is reduced if recirculation mode is selected instead of fresh mode. Fresh mode requires a large amount of energy consumption as the outside air has to be reheated or cooled.
- Close the windows while driving. Driving with the windows open increases air resistance and the usage of the air conditioner or heater.
- When using the air conditioner or heater while driving alone, use the DRIVER ONLY function.
- Always maintain specified tire pressures and use tires for electric vehicles.
- Do not use unnecessary electrical components while driving.
- Do not load unnecessary items in the vehicle.
- Do not mount parts that may increase air resistance.

When the distance to empty is insufficient

- When the battery warning indicator is displayed, immediately charge the vehicle at a nearby charging station.
- Drive energy efficiently following the "Tips for enhancing the distance to empty."
- When the battery level is 0 %, do not try to drive. Move to a safe place and call for help.

Checking the real-time energy status (CHARGE/POWER gauge)

The CHARGE/POWER gauge displays the charging and discharging status of the electric energy produced by the regenerative braking and the energy consumption of the electric motor.

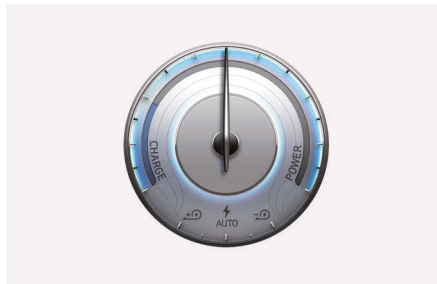

- **CHARGE:** It shows the charging status of the battery, which is charged by the generative brakes, when depressing the brake pedal or decreasing the vehicle speed due to coasting. The more electric energy is charged, the more the gauge level turns counterclockwise.
- **POWER:** It shows the discharging status of the motor when the vehicle is accelerating. The more electric energy is discharged (used), the more the gauge level turns clockwise.

Checking the State of Charge (SOC)

The SOC indicator is displayed at the bottom of the CHARGE/POWER gauge and shows the charge level of the high voltage battery as a percentage. The lower the number, the more the vehicle needs to be charged, and 100 % indicates a full charge.

Type A, B



The SOC indicator shows the state of charge of the high-voltage battery

- When the high voltage battery level is below a certain point, its warning light (🔋) illuminates.
- When the warning light is displayed, charge the vehicle.

***i* Information**

Battery capacity warning level

- Long Range: 20 %
 - Standard: 25 %
 - Cross: 20 %
-

***i* Information**

- Check if the SOC is enough before driving on highways or motorways.
 - After the warning light is displayed, immediately charge the vehicle at a nearby charging station. The vehicle may not operate properly depending on the driving speed, weather, and other driving conditions.
-

Checking the warning and indicator lights



The warning and indicator lights are displayed in the middle of the instrument cluster before or while driving, depending on the status of the electric vehicle. Understand the meaning of the warning and indicator lights referring to the instructions below and drive safely.

CAUTION

If the warning light illuminates while driving or does not go off, we recommend that your vehicle be inspected by an authorized HYUNDAI dealer.



Checking the warning lights

Check the cause of the warning lights referring to the table below and take appropriate measures.

Warning light	Cause	Measure
Service warning light 	This warning light illuminates: <ul style="list-style-type: none"> • When there is a problem with related parts of the electric vehicle control system, such as sensors, etc. • When an actuator, electric compressor for air conditioning, etc. malfunctions. 	In a normal condition, it illuminates for about 3 seconds when the Start/Stop button is in the ON position and then goes off. <ul style="list-style-type: none"> • When the warning light illuminates while driving, or does not go off after starting the vehicle, we recommend that your vehicle be inspected by an authorized HYUNDAI dealer.
High voltage battery level warning light 	This warning light illuminates when the high voltage battery level is low.	Immediately charge the vehicle. The vehicle can drive an additional 30-50 km (20-30 mi). <ul style="list-style-type: none"> • The actual distance to empty depends on the driving conditions.
Regenerative brake warning light 	This warning light illuminates when the regenerative brake does not operate and the brake does not perform well due to the malfunction of the brake system.	We recommend that your vehicle be inspected and repaired by an authorized HYUNDAI dealer <ul style="list-style-type: none"> • The operation of the brake pedal may feel deeper than normal or the braking distance may increase.

Checking the indicator lights

Check the meaning of the indicator lights referring to the table below and take appropriate measures if necessary.

Indicator light	Meaning
<p>Charging indicator light</p> 	<p>Indicates the charging connector is connected to the high voltage battery.</p> <ul style="list-style-type: none"> • When the charging connector is connected, it turns green.
<p>Ready indicator</p> 	<p>Illuminates when the electric vehicle is ready to be driven, and indicates that the vehicle is operable.</p> <ul style="list-style-type: none"> • When the vehicle malfunctions, the indicator goes off or blinks. • If the indicator is turned off or blinks, we recommend that your vehicle be inspected and repaired by an authorized HYUNDAI dealer.
<p>Power down indicator light</p> 	<p>This indicator light illuminates:</p> <ul style="list-style-type: none"> • When the high voltage battery level is too low or voltage is decreasing. (Output limit occurs when the charge level is insufficient.) • When the temperature of the high voltage battery is too high or too low. • When the driving system temperature is overheated and requires protection. <p>If it illuminates alone, it is not failure.</p> <ul style="list-style-type: none"> • If both power down indicator light and service warning light illuminate at the same time, we recommend that your vehicle be inspected by an authorized HYUNDAI dealer. • When the indicator is illuminating, immediately charge the vehicle. The driving speed may be limited and the vehicle may not properly drive uphill.

Checking warning messages

Check the meaning of the warning messages referring to the table below and take appropriate measures.

WARNING

- Do not drive with a warning message displayed.
- If a warning message does not go off after taking measures, we recommend that you have the vehicle immediately inspected and repaired by an authorized HYUNDAI dealer.

Warning message	Cause	Measure
Low EV battery	<ul style="list-style-type: none"> • Standard battery: The high voltage battery level reaches below 25 %. • Long range battery: The high voltage battery level reaches below 20 %. • Cross battery: The high voltage battery level reaches below 20 %. • The (🔋) warning light on the instrument cluster turns on simultaneously. 	Charge the vehicle immediately.
Charge immediately. Power limited	<ul style="list-style-type: none"> • Standard battery: The high voltage battery level reaches below 15 %. • Long range battery: The high voltage battery level reaches below 10 %. • Cross battery: The high voltage battery level reaches below 10 %. • The (🔋) warning light on the instrument cluster turns on simultaneously. • The vehicle's power may be reduced to minimize the energy consumption of the high voltage battery. 	Charge the battery immediately.
Check electric vehicle system	There is a problem with the electric vehicle control system.	<ul style="list-style-type: none"> • Do not drive when the warning message is displayed. • We recommend that you immediately tow the vehicle to an authorized HYUNDAI dealer and have it inspected and repaired.

Warning message	Cause	Measure
<p>Power limited</p>	<p>This warning message is displayed when the power of the vehicle is limited to ensure the safety of high-powered components for the reasons below:</p> <ul style="list-style-type: none"> • The high voltage battery level is too low or voltage is decreasing. • The temperature of the high voltage battery is too high or too low. • When the driving system is overheated and requires protection. 	<p>If it illuminates alone, it did not fail.</p> <ul style="list-style-type: none"> • Charge the vehicle if the charge level is low. • If both power down indicator light and service warning light illuminate at the same time, we recommend that your vehicle be inspected by an authorized HYUNDAI dealer. • Do not accelerate or start the vehicle suddenly when the warning message is displayed. • Be careful when the power down indicator is displayed. The vehicle may not properly drive uphill and roll back on a slope.
<p>Power limited. Low battery temperature</p>	<p>If you start or turn off the vehicle when the outside temperature is low, warning message is displayed to protect electric vehicle system.</p> <ul style="list-style-type: none"> • If the high voltage battery charge level is low and parked outside for a long time, vehicle power could be limited due to the low battery temperature. 	<ul style="list-style-type: none"> • Charging the battery before driving helps increase power. • If this warning message are still displayed even after the ambient temperature has increased, we recommend that your vehicle be inspected and repaired by an authorized HYUNDAI dealer.
<p>Battery overheated! Stop safely</p>	<p>The high voltage battery temperature is too high.</p>	<ul style="list-style-type: none"> • Stop the vehicle in a safe place and turn off the Start/Stop button and wait until the battery temperature decreases. • If these warning messages are still displayed even after turning off the vehicle and waiting for a sufficient time, we recommend that you immediately tow the vehicle to an authorized HYUNDAI dealer for inspection and repair.
<p>Stop safely and check power supply</p>	<p>A failure occurs in the power supply system.</p>	<p>Immediately stop the vehicle in a safe place. We recommend that you tow the vehicle to an authorized HYUNDAI dealer for inspection and maintenance.</p>

Warning message	Cause	Measure
Unplug vehicle to start	You started the vehicle with the charging connector plugged in.	Unplug the charging cable and start the vehicle.
Charging door open	You started the vehicle with the charging door opened.	Check if the charging door is completely closed after charging the vehicle.
Charging stopped. Please check the AC(DC) charger	<p>These warning messages are displayed when charging is stopped for the reasons below:</p> <ul style="list-style-type: none"> • There is a problem with the external AC charger or DC charger. • The external AC charger stopped the charging. • The charging cable is damaged. 	<ul style="list-style-type: none"> • Check whether there is any problem with the external AC or DC charger and charging cable. • Charge the vehicle with an AC charger that has been approved for proper operation or a genuine HYUNDAI portable charger. • If the same problem occurs, we recommend that your vehicle be inspected by an authorized HYUNDAI dealer.
Charging interrupted. Please check the cable connection	<p>These warning message is displayed when charging is stopped for the reasons below:</p> <ul style="list-style-type: none"> • The charging connector is not correctly connected to the charging inlet. • The unlock button on the charging connector is pressed. 	<ul style="list-style-type: none"> • Separate the charging connector from the vehicle and reconnect it. • Check whether there is any problem, such as external damage, foreign substances, etc., with the charging connector and charging inlet. • Charge the vehicle with a charger that has been approved for proper operation or a genuine HYUNDAI portable charger. • If the same problem occurs, we recommend that your vehicle be inspected by an authorized HYUNDAI dealer.

Countermeasures for accidents or fire

When an accident occurs while driving the electric vehicle, turn on the hazard warning flasher, move the vehicle to a safe place, and do not let other people approach the site.

WARNING

When an accident occurs, and the high voltage battery is damaged, harmful gas and electrolytes may leak.

- Be careful not to touch the leaked liquid.
 - When you suspect leakage of inflammable gas and other harmful gases, open the windows and immediately evacuate to a safe location.
 - If any leaked fluid comes in contact with your eyes or skin, immediately clean the affected area thoroughly with tap water or saline solution and have doctors inspect it as soon as possible.
-

If the electric vehicle catches fire

If a fire occurs, evacuate to a safe place and do not let other people approach the site.

- Contact the fire department, report an electric vehicle fire, and then follow its instructions.

CAUTION

- If a fire occurs, evacuate to a safe place and wait until the firefighters arrive.
 - If the lower part of the vehicle where the high voltage battery is located catches fire, large amount of water must be supplied continuously for a long time to completely extinguish the fire. It is hard to extinguish the fire without sufficient water and appropriate fire extinguishers. If you approach the vehicle carelessly, it may cause accidents, such as electric shock, and result in serious injury.
-

If the electric vehicle is submerged

If the electric vehicle is submerged while driving, follow the instructions below:

- Immediately turn off the vehicle and evacuate to a safe place with your key.
- Contact the emergency rescue service such as a fire department, or an authorized HYUNDAI dealer.

WARNING

Never touch the submerged electric vehicle. This may lead to an accident such as an electric shock or fire.

If the electric vehicle needs towing

If towing is required, lift all wheels to tow. Towing with the wheels on the ground may damage the vehicle's motor components.

CAUTION

Contact the fire department when towing the vehicle after a fire. When a vehicle fire occurs due to the battery, there is a risk of a second fire.

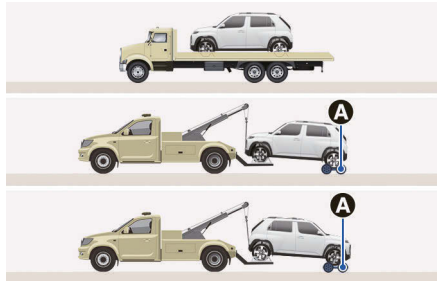

[A] Dollies

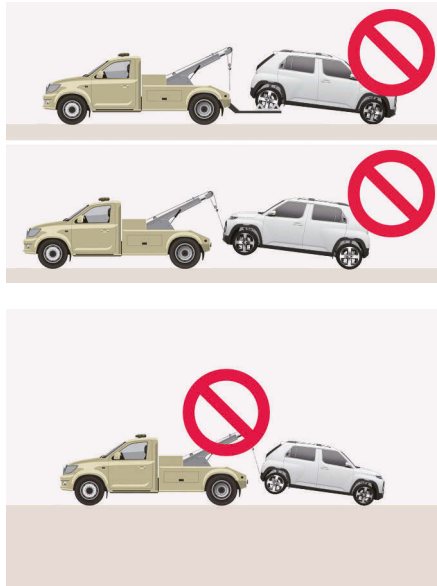

Other precautions for electric vehicle accidents

CAUTION

- Be extremely cautious for electricity safety. An electric shock accident may occur due to a short circuit in high voltage power.
 - When you paint or apply heat treatment to the vehicle as a result of an accident, the performance of the high voltage battery can be reduced. If heat treatment is required, we recommend that you contact an authorized HYUNDAI dealer.
 - Use or install only genuine parts. Third-party parts or modified parts may damage the electric power system.
-

2. Vehicle information

- Exterior overview (Front View) 2-2
- Exterior overview (Rear View) 2-4
- Interior overview..... 2-6
- Center console overview 2-9
- Steering wheel control overview..... 2-13
- Motor Compartment Overview 2-14
- Dimensions 2-15
- Electric vehicle specifications 2-15
- Bulb wattage..... 2-16
- Tires and wheels 2-18
- Load and speed capacity tires..... 2-19
- Air conditioning system 2-19
- Vehicle weight and luggage volume 2-20
- Recommended lubricants and capacities 2-20
- Vehicle Identification Number (VIN)..... 2-21
- Vehicle certification label 2-21
- Tire specification and pressure label 2-21
- Motor number 2-21
- Air conditioner compressor label 2-22
- Declaration of conformity..... 2-22
- Importer information (for Europe) 2-22
- Open source software notice 2-22
- IMPORTER & DISTRIBUTOR INFORMATION FOR EU BATTERY REGULATION (EU 2023/1542)..... 2-23

Exterior overview (Front View)

Front view

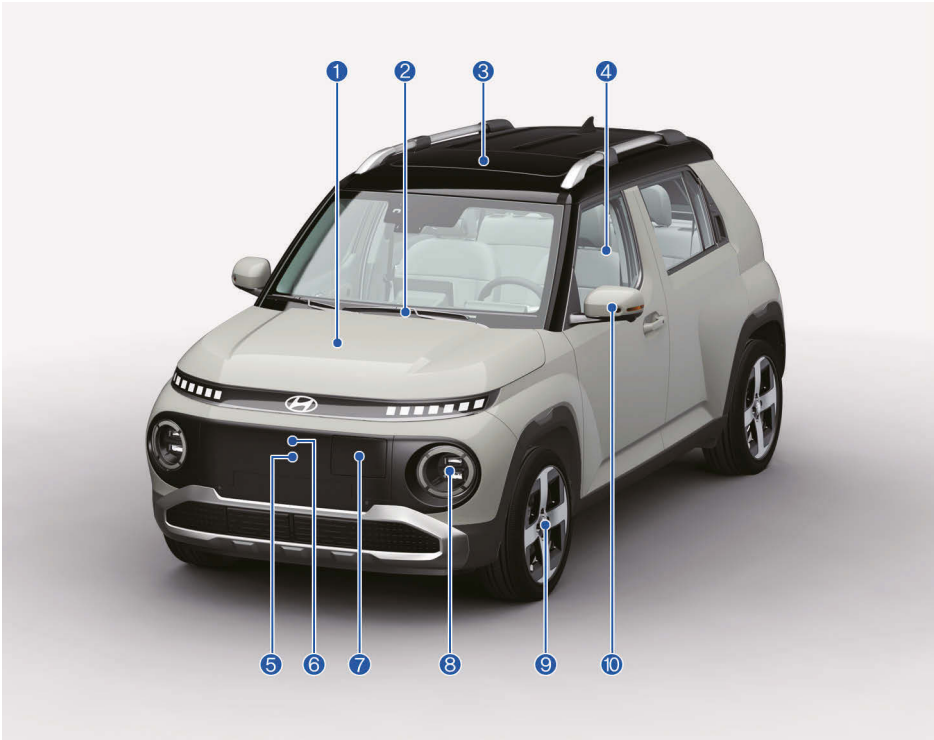

The actual shape may differ from the illustration.

(1) Hood	5-38
(2) Front windshield wiper blades	5-55, 9-17
(3) Sunroof	5-34
(4) Windows	5-31
(5) Front radar	7-17
(6) Wide-front view camera	7-4
(7) Electric charging door	5-41
(8) Headlight	5-44, 9-42
(9) Tires and wheels	9-22
(10) Outside rearview mirror	5-29

Front view - Cross



The actual shape may differ from the illustration.

(1) Hood	5-38
(2) Front windshield wiper blades	5-55, 9-17
(3) Roof basket	5-86
(4) Windows	5-31
(5) Front radar	7-17
(6) Wide-front view camera	7-4
(7) Electric charging door	5-41
(8) Headlight	5-44, 9-42
(9) Tires and wheels	9-22
(10) Outside rearview mirror	5-29

Exterior overview (Rear View)

Rear view

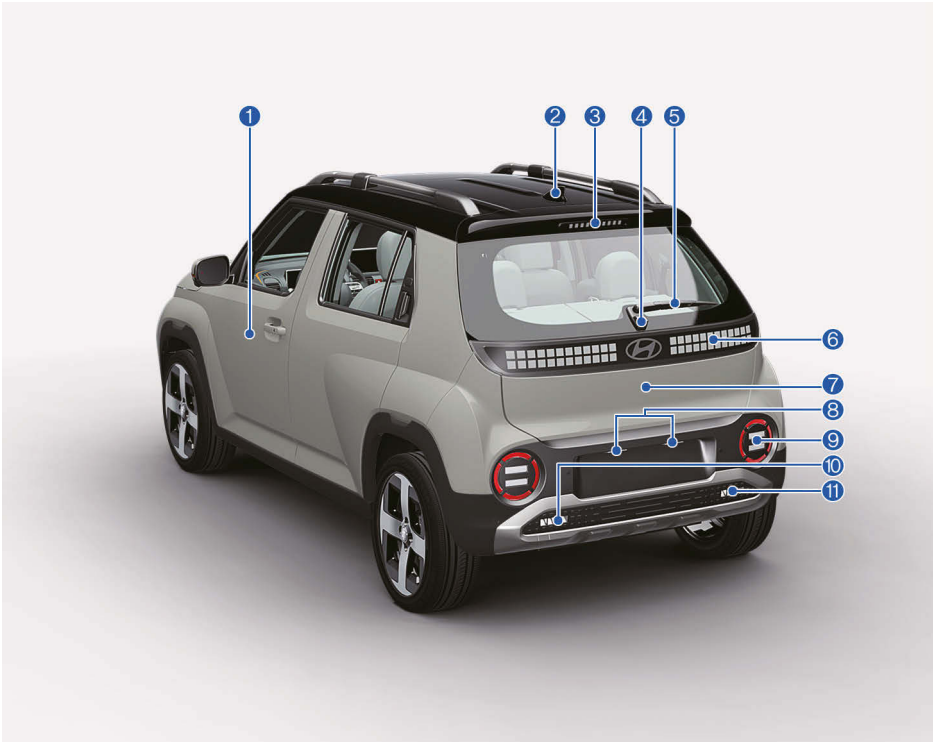

The actual shape may differ from the illustration.

(1) Door	5-19
(2) Antenna	5-88
(3) High mounted stop light	9-49
(4) Wide-rear view camera	7-124
(5) Rear window wiper blades	5-57, 9-17
(6) Rear combination light	5-44, 9-47
(7) Tailgate	5-39
(8) License plate light.....	9-47
(9) Turn signal light/Assist tail light	9-47
(10)Rear fog light (Left-hand drive) / Back up light (Right-hand drive)	9-47
(11) Back up light (Left-hand drive) / Rear fog light (Right-hand drive).....	9-47

Rear view - Cross

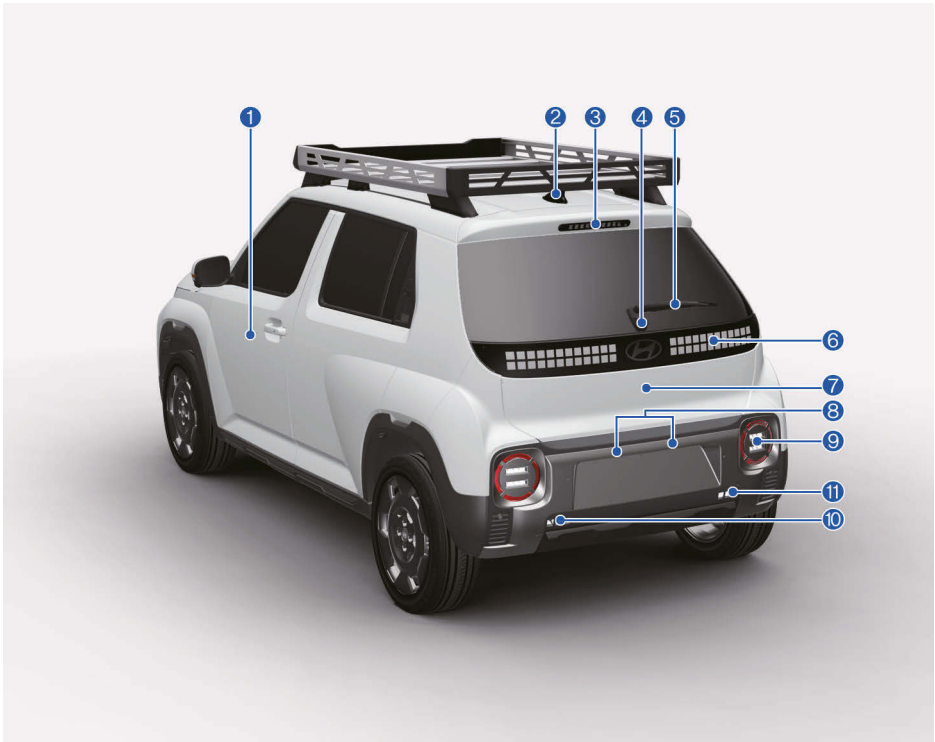

The actual shape may differ from the illustration.

(1) Door	5-19
(2) Antenna	5-88
(3) High mounted stop light	9-49
(4) Wide-rear view camera	7-124
(5) Rear window wiper blades	5-57, 9-17
(6) Rear combination light	5-44, 9-47
(7) Tailgate	5-39
(8) License plate light	9-47
(9) Turn signal light/Assist tail light	9-47
(10)Rear fog light (Left-hand drive) / Back up light (Right-hand drive)	9-47
(11) Back up light (Left-hand drive) / Rear fog light (Right-hand drive).....	9-47

Interior overview

Left-hand drive

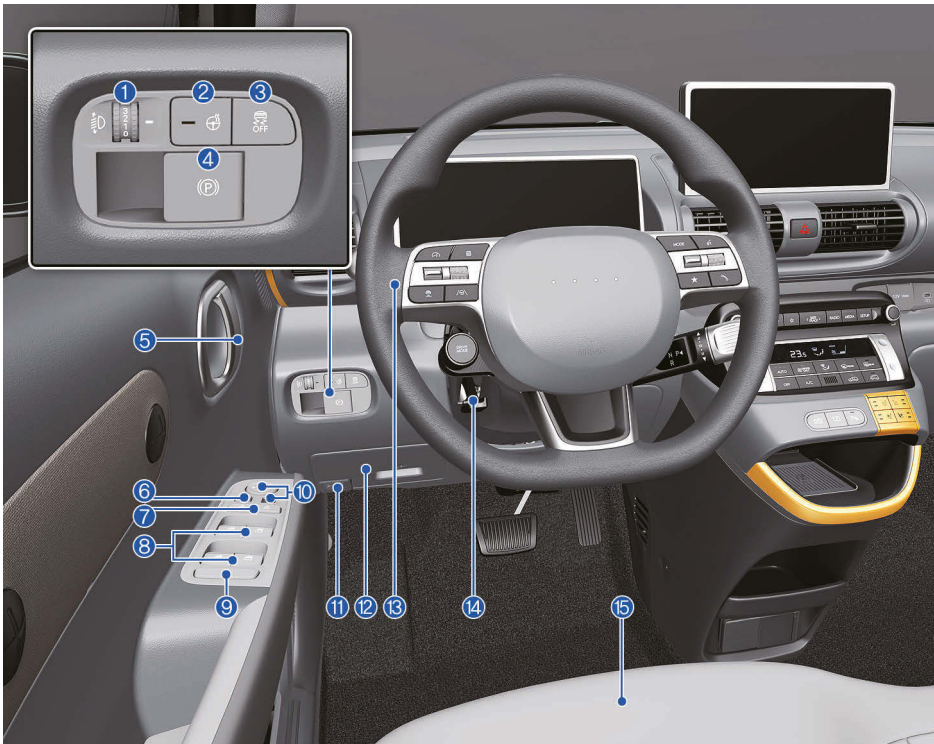

The actual shape may differ from the illustration.

(1) Headlight leveling device	5-47
(2) Steering wheel heater	5-26
(3) ESC (Electronic Stability Control) OFF button	6-31
(4) EPB (Electronic Parking Brake) switch	6-24
(5) Inside door handle	5-20
(6) Outside rearview mirror folding button	5-29
(7) Central door lock switch	5-20
(8) Power window switches	5-31
(9) Power window lock button	5-33
(10) Outside rearview mirror control switch	5-29
(11) Hood release lever	5-38
(12) Fuse box	9-30
(13) Steering wheel	5-25

(14)Steering wheel tilt/telescopic switch	5-25
(15)Seat	3-5

Right-hand drive

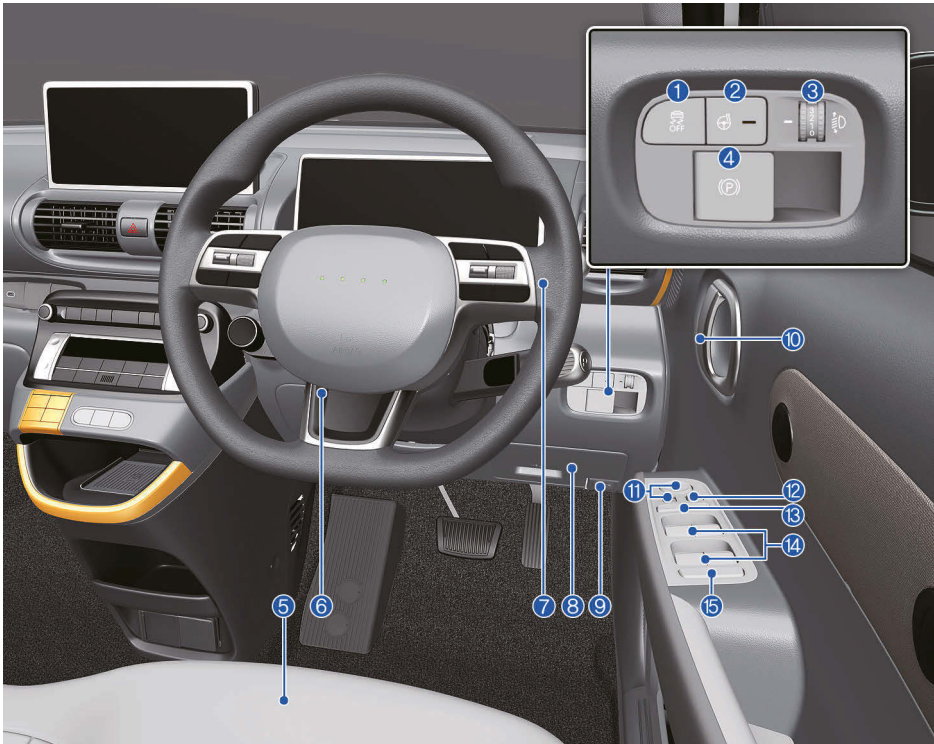

The actual shape may differ from the illustration.

(1) ESC (Electronic Stability Control) OFF button	6-31
(2) Steering wheel heater	5-26
(3) Headlight leveling device	5-47
(4) EPB (Electronic Parking Brake) switch	6-24
(5) Seat	3-5
(6) Steering wheel tilt/telescopic switch	5-25
(7) Steering wheel	5-25
(8) Fuse box	9-30
(9) Hood release lever	5-38
(10) Inside door handle	5-20
(11) Outside rearview mirror control switch	5-29
(12) Outside rearview mirror folding button	5-29
(13) Central door lock switch	5-20
(14) Power window switches	5-31
(15) Power window lock button	5-33

Center console overview



The actual shape may differ from the illustration.

(1) Horn	5-27
(2) Instrument cluster	4-2
(3) Driver's front air bag	3-40
(4) Start/Stop button	6-4
(5) Hazard warning flasher switch	8-2
(6) Infotainment system	5-89
(7) Automatic climate control system	5-58
(8) Glove box	5-75
(9) Passenger's front air bag	3-40
(10) Auto Hold button	6-27
(11) Parking/View button	7-122
(12) Parking Safety button	7-151
(13) Seat warmer	3-16

Vehicle information

(14)Air ventilation seat	3-17
(15)Wireless smartphone charging system	5-79
(16)USB Port	5-87
(17)Power outlet	5-77
(18)USB Charger (C type)	5-78

Right-hand drive

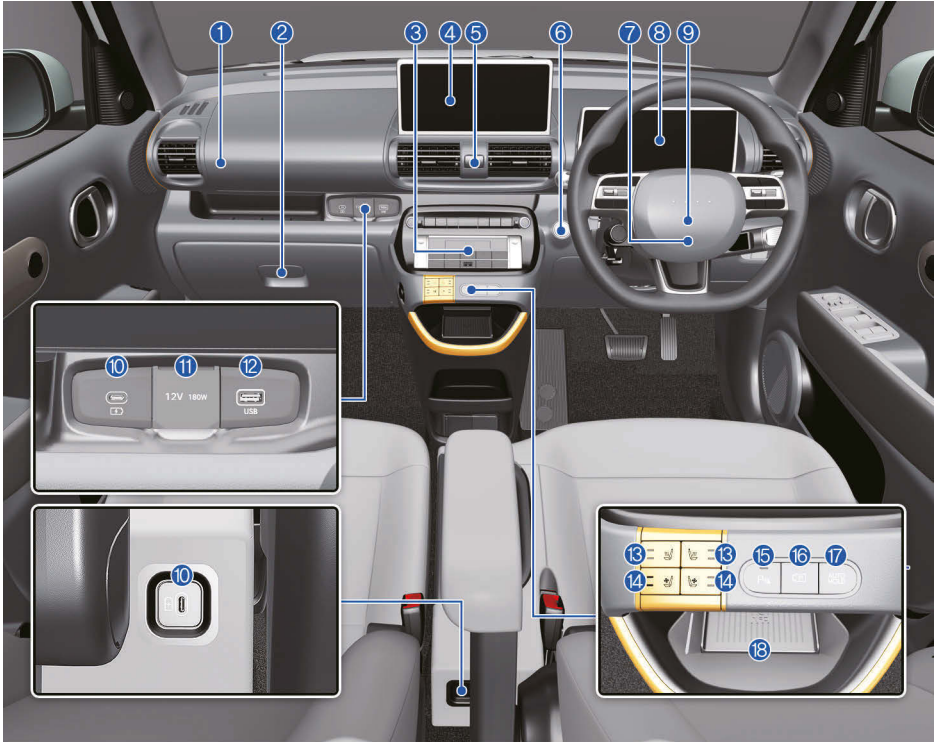

The actual shape may differ from the illustration.

(1) Passenger's front air bag	3-40
(2) Glove box	5-75
(3) Automatic climate control system	5-58
(4) Infotainment system	5-89
(5) Hazard warning flasher switch	8-2
(6) Start/Stop button	6-4
(7) Driver's front air bag	3-40
(8) Instrument cluster	4-2
(9) Horn	5-27
(10) USB Charger (C type)	5-78
(11) Power outlet	5-77
(12) USB Port	5-87
(13) Seat warmer	3-16
(14) Air ventilation seat	3-17
(15) Parking Safety button	7-151

Vehicle information

(16) Parking/View button	7-122
(17) Auto Hold button	6-27
(18) Wireless charging system indicator	5-79

Steering wheel control overview

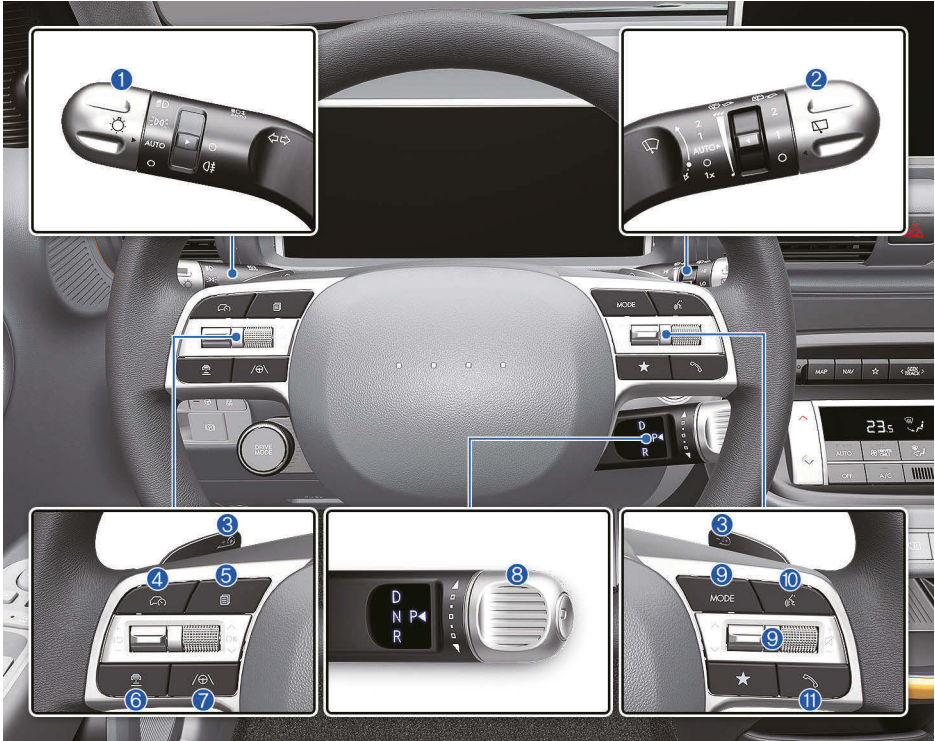

The actual shape may differ from the illustration.

(1) Lighting control lever	5-44
(2) Wiper and washer control lever	5-55
(3) Paddle shifter	6-14
(4) Driving Assist button	7-90
(5) Cluster display controls	4-31
(6) Vehicle Distance button	7-90
(7) Lane Driving Assist button	7-36
(8) Rotary shifter (Rotary gear shift dial)	6-8
(9) Audio remote control buttons	5-88
(10) Voice recognition button	5-89
(11) Bluetooth® hands-free phone button	5-89

Motor Compartment Overview

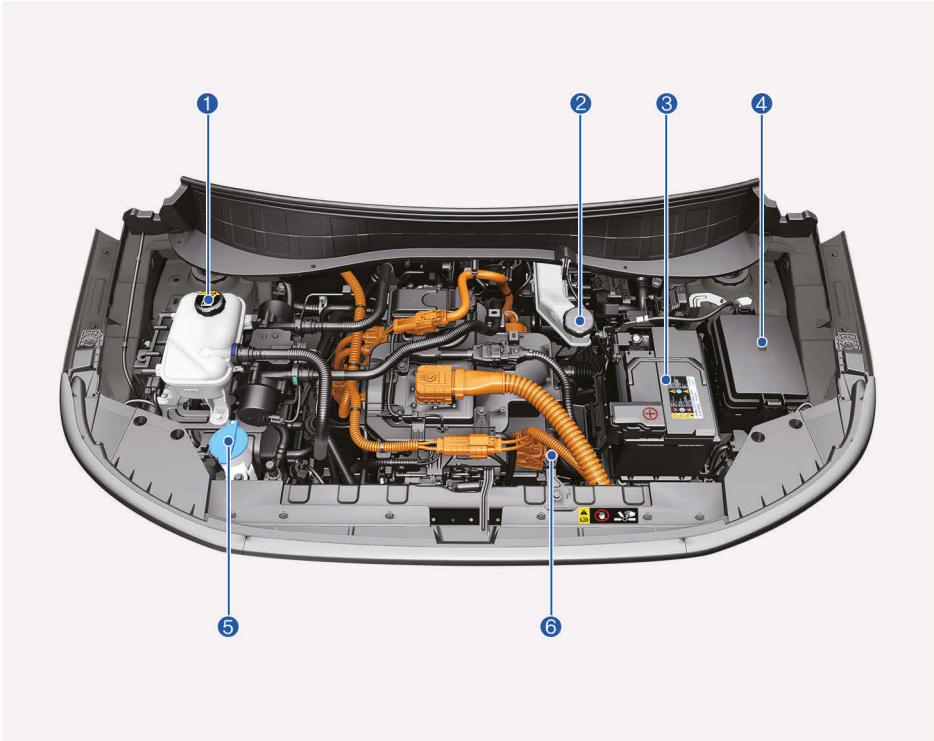

The actual motor compartment in the vehicle may differ from the illustration.

(1) Coolant reservoir	9-12
(2) Brake fluid reservoir	9-14
(3) Battery (12 V)	9-19
(4) Fuse box	9-29
(5) Windshield washer fluid reservoir	9-15
(6) Emergency cable	1-20

Dimensions

Items		mm (in.)	
		INSTER	INSTER Cross
Overall length		3,825 (150.59)	3,845 (151.38)
Overall width		1,610 (63.39)	1,610 (63.39)
Overall height		1,575 (62.01) / 1,610 (63.39) *1	1,575 (62.01) / 1,610 (63.39) *1 / 1,715 (67.52) *2
Front tread	185/65 R15	1,414 (55.67)	1,414 (55.67)
	205/45 R17	1,402 (55.20)	1,402 (55.20)
Rear tread	185/65 R15	1,425 (56.10)	1,425 (56.10)
	205/45 R17	1,413 (55.63)	1,413 (55.63)
Wheelbase		2,580 (101.57)	2,580 (101.57)

*1 with roof side rails

*2 with roof basket

Electric vehicle specifications

Items		Standard	Long range
Motor	Max. output (kW)	71.1	84.5
	Max. torque (N·m)	147	147
Battery (Lithium-ion)	Capacity (kWh)	42	49
	Power output (kW)	85.4	96.5
	Voltage (V)	266	310
Charger (OBC: On-Board Battery Chargers [with 3-phase current])	Max. output (kW)	10.5	10.5

Bulb wattage

Light bulb		Bulb type	Wattage	
Front	Headlight (Low/High)	Type A	H19	55/60W
		Type B	LED	LED
	Turn signal light		LED	LED
	Position light		LED	LED
	Daytime running light		LED	LED
	Side repeater light (Fender)		WY5W	5W
	Side repeater light (Outside mirror)		LED	LED
Rear	Stop light	Type A	P21/5W	21/5W
		Type B	LED	LED
	Tail light	Type A	W5W	5W
		Type B	LED	LED
	Turn signal light		LED	LED
	Backup light		LED	LED
	High mounted stop light	Type A	W5W	5W
		Type B	LED	LED
	Fog light		LED	LED
	License plate light	Type A	W5W	5 W
Type B		LED	LED	

Light bulb		Bulb type	Wattage	
Interior	Map lamp	Type A	W10W	10W
		Type B	FESTOON	8W
		Type C	LED	LED
	Room lamp	Type A	FESTOON	8W
		Type B	LED	LED
	Cargo area lamp	Type A	FESTOON	10W
		Type B	LED	LED
	Vanity mirror lamp	Type A	FESTOON	5 W
		Type B	LED	LED
	Mood lamp (Front seat door lamp, Passenger seat open tray lamp)		LED	LED

Tires and wheels

Items	Tire size	Wheel size	Inflation pressure kPa (psi)				Wheel nut torque kgf-m (lbf-ft, N·m)
			Normal load		Maximum load		
			Front	Rear	Front	Rear	
Full size tire	185/65 R15	5.5JX15	250 (36)	250 (36)	250 (36)	260 (38)	11-13 (79-94, 107-127)
	205/45 R17	6.5JX17	250 (36)/ 255 (37) *1	235 (34)/ 235 (34) *1	250 (36)/ 260 (38) *1	260 (38)/ 260 (38) *1	

*1 Cross

NOTICE

- It is permissible to add 20 kPa (3 psi) to the standard tire pressure specification if colder temperatures are expected soon.
Tires typically lose 7 kPa (1 psi) for every 7 °C (12 °F) temperature drop. If extreme temperature variations are expected, recheck your tire pressure as necessary to keep them properly inflated.
- Tire inflation pressures may differ depending on changes in elevation (about 10 kPa (2.4 psi) for every 1 km (1 mi.) elevation change). If driving in areas of higher or lower elevation, be sure to check and adjust for proper tire inflation.
- Do not exceed the maximum inflation pressure, as found on the sidewall of the tire(s).
- No spare tire is provided as this vehicle provides Tire Mobility Kit (TMK).

CAUTION

When replacing tires, ALWAYS use the same size, type, brand, construction, and tread pattern supplied with the vehicle. If not, it can damage the related parts or make it work irregularly.

Load and speed capacity tires

Items	Tire size	Wheel size	Load capacity		Speed capacity	
			LI*1	kg	SS*2	km/h
Full size tire	185/65 R15	5.5JX15	88	560	H	210
	205/45 R17	6.5JX17	88	560	V	240

*1 LOAD INDEX

*2 SPEED SYMBOL

Air conditioning system

Item		Weight of volume	Classification
Refrigerant	Type A	Heat pump	550±25 g (19.4±0.9 oz.)
		Without heat pump	475±25 g (16.75±0.9 oz.)
	Type B	Heat pump	600±25 g (21.16±0.9 oz.)
		Without heat pump	525±25 g (18.52±0.9 oz.)
Compressor lubricant		180±10 g (6.35±0.35 oz.)	REF POE-1

We recommend that you contact an authorized HYUNDAI dealer for more information.

Vehicle weight and luggage volume

Item		Value
Gross vehicle weight	Standard	1,730 kg (3,813 lbs.)
	Long range	1,745 kg (3,847 lbs.)
	Long range Cross	1,790 kg (3,946 lbs.)
Luggage volume	Max. with TMK	1,059 ℓ (37.40 cu ft.)
	Min. with TMK	280 ℓ (9.89 cu ft.)

Recommended lubricants and capacities

To help achieve proper vehicle performance and durability, use only lubricants of the proper quality.

These lubricants and fluids are recommended for use in your vehicle.

Lubricant			Volume	Classification
Reduction gear fluid			0.75 ± 0.03 ℓ (0.79 ± 0.03 US qt.)	HK ATF 65 SP4M-1
Coolant	Standard	with heat pump	8.79 ℓ (9.29 US qt.)	Mixture of antifreeze and water (Phosphate-based Ethylene glycol coolant Battery for aluminum radiator)
		without heat pump	8.68 ℓ (9.17 US qt.)	
	Long range	with heat pump	8.79 ℓ (9.29 US qt.)	
		without heat pump	8.68 ℓ (9.17 US qt.)	
	Long range Cross	with heat pump	8.79 ℓ (9.29 US qt.)	
		without heat pump	8.68 ℓ (9.17 US qt.)	
Brake fluid			As needed	SAE J1704 DOT-4 LV, FMVSS 116 DOT-4, ISO 4925 CLASS-6

Vehicle Identification Number (VIN)

Frame number



The vehicle identification number (VIN) is the number used in registering your vehicle and in all legal matters pertaining to its ownership, etc.

The number is punched on the floor under the right front seat. To check the number, open the cover.

Vehicle certification label



The vehicle certification label attached on the driver's (or front passenger's) side center pillar gives the vehicle identification number (VIN).

Tire specification and pressure label



The tires supplied on your new vehicle are chosen to provide the best performance for normal driving.

The tire label located on the driver's side center pillar gives the tire pressures recommended for your vehicle.

Motor number



The motor numbers can be checked at the bottom of the vehicle.

Air conditioner compressor label

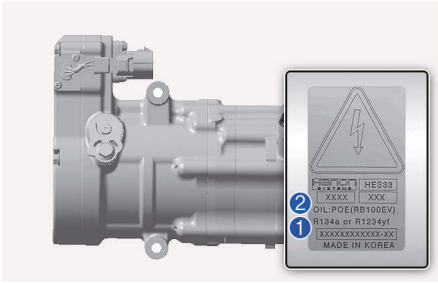

A compressor label informs you the type of compressor your vehicle is equipped with such as model, supplier part number, production number, refrigerant (1) and refrigerant oil (2).

Declaration of conformity

 if equipped

Example



The radio frequency components of the vehicle comply with requirements and other relevant provisions of Directive 1995/5/EC.

Further information including the manufacturer's declaration of conformity is available on HYUNDAI website as follows;

<http://service.hyundai-motor.com>

Importer information (for Europe)

Hyundai Motor Europe GmbH
Kaiserleipromenade 5, 63067 Offenbach,
Germany.
T +49 (0) 69 27 1472 -0
www.hyundai.com/eu

Open source software notice

This vehicle contains software with open source licenses. Open source software information including the source code, copyright notices and referred license terms may be obtained on the website

<https://www.hyundai.com/worldwide/opensource>

HYUNDAI Motor Company will provide the open source code to you in storage medium such as CD-ROM for minimum charge covering the cost of performing source distribution upon email request to opensource@hyundai.com within a period of 3 years from the date of product purchase.

IMPORTER & DISTRIBUTOR INFORMATION FOR EU BATTERY REGULATION (EU 2023/1542)

Provide importer and distributor information on the battery parts below.

Battery Type (If equipped)	
Electric vehicle battery	SLI battery
Portable battery	Portable battery of General use

1. Name of Importer & Distributor:
Hyundai Motor Europe GmbH
2. Trade Name: Hyundai
3. Address: Kaiserleipromenade 5, 63067 Offenbach, Germany
4. Single contact point: +49 (0) 69 271472 -0
5. Web address: www.hyundai.com/eu
6. E-mail:
customercare@hyundai-europe.com

Manufacturer Information EV High Voltage Battery



Manufacturer

Valeo Kapec Co., Ltd

- Address: 22, SeongjuSaneopdanjiro 2-gil, Seongju-eup, Seongjugun, Gyeongsangbuk-do, Republic of Korea (40031)

Manufacturer Information SLI Battery



Manufacturer

HYUNDAI SUNGWOOLITE Co..LTD.

- Battery Type: SLI Battery
- Address: 609, Bongeunsa-ro, Gangnam-gu, Seoul, Republic of Korea 183-12, Yongmyenggongdan-gil, Geongcheon-eup, Gyeongju-si, Gyeongsangbuk-do, Korea

Manufacturer Information (if equipped) Smart key



Manufacturer

Energy Device Business Division
Panasonic Energy Co., Ltd.

- Battery Type: CR 2032
- Address: 1-1 Matsushita, Moriguchi City, Osaka, 570-8511, Japan, Tel+81-6-6991-1141
- Website: <https://www.panasonic.com/global/energy.html>

Manufacturer

SM BEXEL

- Battery Type: CR 2032
- Address: 168, Sanho-daero, Gumisi, Gyeongsangbuk-do, Republic of Korea
- Website: <https://www.bexel.co.kr/html/index/index.php>

Manufacturer

Energy Device Business Division
Panasonic Energy Co., Ltd.

- Battery Type: CR2450
- Address: 1-1 Matsushita, Moriguchi City, Osaka, 570-8511, Japan, Tel+81-6-6991-1141
- Website: <https://www.panasonic.com/global/energy.html>

Manufacturer Information (if equipped) Remote key precautions



Manufacturer

Energy Device Business Division
Panasonic Energy Co., Ltd.

- Battery Type: CR 2032
- Address: 1-1 Matsushita, Moriguchi City, Osaka, 570-8511, Japan, Tel+81-6-6991-1141
- Website: <https://www.panasonic.com/global/energy.html>

Manufacturer

SM BEXEL

- Battery Type: CR 2032
- Address: 168, Sanho-daero, Gumisi, Gyeongsangbuk-do, Republic of Korea
- Website: <https://www.bexel.co.kr/html/index/index.php>

Manufacturer Information eCall system (if equipped)



Manufacturer

TWS

- Battery Type: Portable Battery
- Address: No.39 Nanyunsan Road, Science Park, Hi-Tech Industrial Development Zone, Guangzhou, China
- Tel: + 86-20-2221 5006
- Website: www.tws.com
- Email: Linda.Xu@tws.com

Manufacturer

SkyPower Enterprise Co., Ltd / 元泰發實業有限公司

- Battery Type: Portable Battery
- Address: 28F, No. 289, Sec 2 Wen-Hua Rd., Ban-Ciao District, New Taipei City, Taiwan
- Tel: +886 2 2258 2986 EXT.265
- Website: www.skypowertek.com
- Email: sean_yang@skypowertek.com

Manufacturer Information TPMS Battery (if equipped)



Manufacturer

EVE Energy co., Ltd.

Murata Manufacturing Co., Ltd.

Maxell, Ltd.

Panasonic Energy Co., Ltd.

- Battery Type: CR2032 or CR2050 or CR2450

complies with the essential requirements of Regulation (EU)2023/1542

- Address:

- EVE Energy co., Ltd.: NO.38, Hui Feng 7th Road, Zhongkai Hi-Tech Zone, HuiZhou, Guangdong, China
- Murata Manufacturing Co., Ltd.: 10-1, Higashikotari 1-chome, Nagaokakyo-shi, Kyoto 617-8555, Japan
- Maxell, Ltd.: Takumidai 5, Ono-shi, Hyogo, 675-1322 Japan
- Panasonic Energy Co., Ltd: 1-1 Matsushita-cho, Moriguchi City, Osaka 570-8511, Japan

3. Seats & Safety system

- Important safety precautions 3-3
 - Always wear your seat belt..... 3-3
 - Restrain all children 3-3
 - Airbag hazards..... 3-3
 - Driver distraction 3-3
 - Never drink or take drugs and drive 3-3
 - Control your speed 3-4
 - Keep your vehicle in safe condition..... 3-4
- Seats 3-5
 - Safety precautions 3-7
 - Front seats 3-8
 - Rear seats 3-10
 - Folding the seats..... 3-11
 - Headrest 3-13
- Seats warmers 3-16
- Air ventilation seats 3-17
- Seat belts..... 3-18
 - Seat belt safety precautions 3-18
 - Seat belt warning light..... 3-19
 - Seat belt restraint system..... 3-20
 - Additional seat belt safety precautions..... 3-23
 - Care of seat belts 3-25
- Child Restraint System (CRS) 3-26
 - Our recommendation: Children always in the rear 3-26
 - Selecting a Child Restraint System (CRS) 3-27
 - Installing a Child Restraint System 3-28
- Airbag - supplemental restraint system..... 3-36
 - SRS Components 3-39
 - Where are the airbags? 3-40
 - How does the airbags system operate? 3-43
 - What to expect after an airbag inflates 3-46
 - Do not install a Child Restraint System on the front passenger's seat 3-47
 - SRS warning light..... 3-47
 - Why didn't my airbag go off in a collision? 3-48
 - SRS care..... 3-51

Additional safety precautions.....	3-51
Airbag warning labels.....	3-52

Important safety precautions

You will find many safety precautions and recommendations throughout this section, and throughout this manual. The safety precautions in this section are among the most important.

Always wear your seat belt

A seat belt is your best protection in all types of accidents. Airbags are designed to supplement seat belts, not to replace them. So even though your vehicle is equipped with airbags, always make sure you and your passengers wear your seat belts, and wear them properly.

Restrain all children

All children under age 13 should ride in your vehicle properly restrained in a rear seat, not the front seat. Infants and small children should be restrained in an appropriate Child Restraint System. Larger children should use a booster seat with the lap/shoulder belt until they can use the seat belt properly without a booster seat.

Airbag hazards

While airbags can save lives, they can also cause serious or fatal injuries to occupants who sit too close to them, or who are not properly restrained. Infants, young children, and short adults are at the greatest risk of being injured by an inflating airbag. Follow all instructions and warnings in this manual.

Driver distraction

Driver distraction presents a serious and potentially deadly danger, especially for inexperienced drivers. Safety should be the primary concern when behind the wheel and drivers need to be aware of the wide array of potential distractions, such as drowsiness, reaching for objects, eating, personal grooming, other passengers, and using mobile phones.

Drivers can become distracted when they take their eyes and attention off the road or their hands off the wheel to focus on activities other than driving. To reduce your risk of distraction and an accident:

- Set up your mobile devices (For example, MP3 players, phones, navigation units, etc.) **ONLY** when your vehicle is parked or safely stopped.
- **ONLY** use your mobile device when allowed by laws and conditions permit safe use. **NEVER** text or email while driving. Most countries have laws prohibiting drivers from texting. Some countries and cities also prohibit drivers from using handheld phones.
- **NEVER** let the use of a mobile device distract you from driving. You have a responsibility to your passengers and others on the road to always drive safely, with your hands on the wheel as well as your eyes and attention on the road.

Never drink or take drugs and drive

Drinking alcohol or taking drugs can reduce your ability to respond to changing conditions and emergencies. Do not drink or take drugs and drive, and do not let your friends drink or take drugs and drive.

Control your speed

Excessive speed is a major factor in crash injuries and deaths. Generally, the higher the speed, the greater the risk, but serious injuries can also occur at lower speeds. Never drive faster than is safe for current conditions, regardless of the maximum speed posted.

Keep your vehicle in safe condition

Having a tire blowout or a mechanical failure can be extremely hazardous. To reduce the possibility of such problems, check your tire pressures and condition frequently, and perform all regularly scheduled maintenance.

Seats

4-seater



- (1) Front seat warmer (if equipped)
- (2) Front Air ventilation seat (if equipped)
- (3) Front forward or rearward
- (4) Front seat height
- (5) Front seatback angle/seatback folding lever (if equipped)
- (6) Headrest (Front)
- (7) Headrest (Rear)
- (8) Rear seatback angle/seatback folding lever (if equipped)
- (9) Rear forward or rearward (if equipped)

2-seater (VAN)

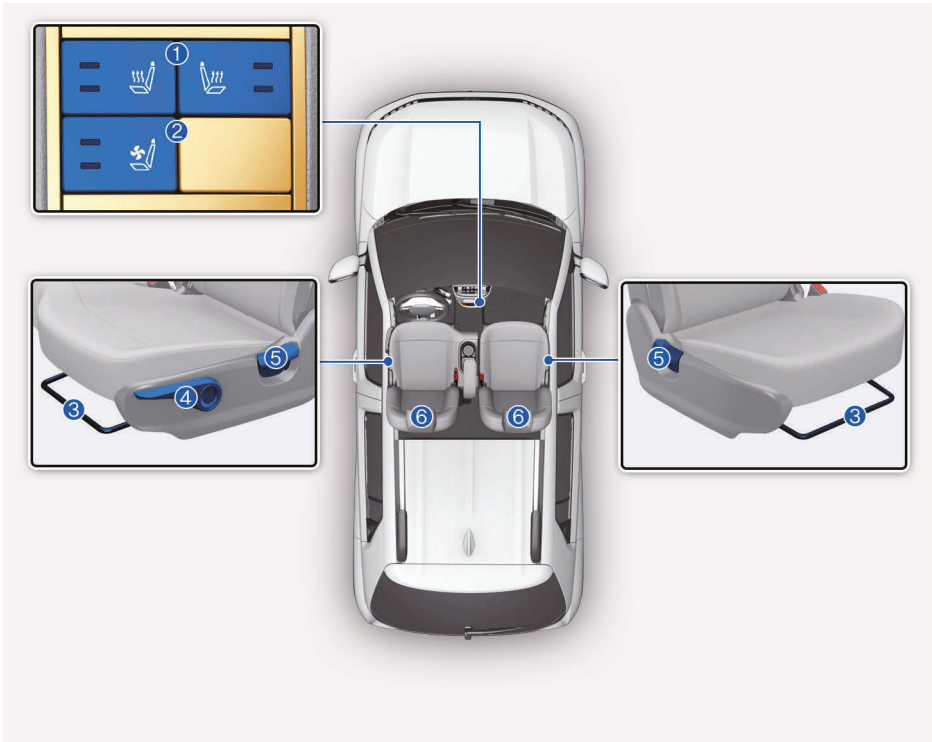

- (1) Seat warmer (if equipped)
- (2) Driver air ventilation seat (if equipped)
- (3) Forward or rearward
- (4) Seat height
- (5) Seatback angle/Seatback folding lever (if equipped)
- (6) Headrest

***i* Information**

The information provided may differ depending on which functions are applicable to your vehicle.

Safety precautions

Adjusting the seats so that you are sitting in a safe and comfortable position plays an important role for the safety of the driver and passengers, as much as seat belts and airbags when in an accident.

WARNING

Do not use a cushion that reduces friction between the seat and the passenger. The passenger's hips may slide under the lap portion of the seat belt during an accident or a sudden stop.

Serious or fatal internal injuries could result because the seat belt cannot operate properly.

Airbags

You can take steps to reduce the risk of being injured by an inflating airbag. Sitting too close to an airbag greatly increases the risk of injury in the event the airbag inflates. Move your seat as far back as possible from front airbags, while still maintaining control of the vehicle.

WARNING

To reduce the risk of serious injury or death from an inflating airbag:

- Adjust the driver's seat as far to the rear as possible while maintaining your ability to control the vehicle.
 - Adjust the front passenger seat as far to the rear as possible.
 - Hold the steering wheel by the rim with your hands at the 9 o'clock and 3 o'clock positions to minimize the risk of injuries to your hands and arms.
 - Never place anything or anyone between you and the airbag.
 - Do not allow the front passenger to place feet or legs on the dashboard to minimize the risk of leg injuries.
-

Seat belts

Always fasten your seat belt before starting any trip. At all times, passengers should sit upright and be properly restrained with a seat belt. Infants and small children must be restrained in appropriate Child Restraint Systems. Children who have outgrown a booster seat and adults must be restrained using the seat belts.

WARNING

To prevent serious injury or death:

- Never use one seat belt for more than one occupant.
 - Always position the seatback upright with the lap portion of the seat belt snug and low across the hips.
 - Never allow children or small infants to ride on a passenger's lap.
 - Do not route the seat belt across your neck, across sharp edges, or reroute the shoulder strap away from your body.
 - Do not allow the seat belt to become caught or jammed.
-

Front seats

WARNING

To prevent serious injury or death:

- Never attempt to adjust the seat while the vehicle is moving. The seat could respond with unexpected movement and may cause loss of vehicle control resulting in a collision.
 - Do not place anything under the front seats. Loose including unsecured floor mats, in the driver's foot area could interfere with the operation of the foot pedals.
 - Do not allow anything to interfere with the normal position and proper locking of the seatback.
 - Do not place a cigarette lighter on the floor or seat.
 - Use extreme caution when picking up small objects trapped under the seats or between the seat and the center console. Your hands might be cut or injured by the sharp edges of the seat mechanism.
 - If there are occupants in the rear seats, be careful while adjusting the front seat.
 - Make sure that the seat is locked in place after the adjustment. If not, the seat might move unexpectedly.
-

Reclining seatback

Sitting in a reclined position when the vehicle is moving can be dangerous. Even when buckled up, the protections of your restraint system (seat belts and/or airbags) is greatly reduced by reclining your seatback.

Seat belts must be snug against your hips and chest to work properly.

The more the seatback is reclined, the greater the chance for the passenger's hips to slide under the lap belt or the passenger's neck to strike the shoulder belt.

WARNING

Never ride with a reclined seatback when the vehicle is moving.

Riding with a reclined seatback increases your chance of serious or fatal injuries in the event of a collision or sudden stop.

Driver and passengers should always sit well back in their seats, properly belted, and with the seatbacks upright.

Seat belts must be snug against your hips and chest to work properly. When the seatback is reclined, the shoulder belt cannot do its job because it will not be snug against your chest. Instead, it will be in front of you. During a collision, you could be thrown into the seat belt, causing neck or other injuries.

The more the seatback is reclined, the greater chance the passenger's hips will slide under the lap belt or the passenger's neck will strike the shoulder belt.

Seat adjustment

The front seat can be adjusted by using the levers located underneath the front part of the seat or on the outer side of the seat.

Forward and rearward adjustment



To move the seat forward or rearward:

1. Pull up the seat slide adjustment lever [A] and hold it.
2. Slide the seat to the desired position.
3. Release the lever [A] and make sure the seat is locked in place. Move forward and rearward without using the lever. If the seat moves, it is not locked properly.

Seatback angle

if equipped



To recline the seatback:

1. Lean forward slightly and lift up the seatback lever [A].
2. Carefully lean back on the seat and adjust the seatback to the desired position.
3. Release the lever [A] and make sure the seatback is locked in place.

Seat height



To change the height of the seat cushion:

- Push down on the lever [A] several times, to lower the seat cushion.
- Pull up on the lever [A] several times, to raise the seat cushion.

Armrest

 if equipped



The armrest is located in the driver's seat. Pull the armrest down to use it.

CAUTION

Do not sit on the armrest.

WARNING

- Do not adjust while driving.
- Lift the armrest and return it to its original position. Make sure the armrest has been firmly fixed. Otherwise, the armrest may fall if you make a sudden stop, which could result in injury.

Rear seats

Seat adjustment

 if equipped

Forward and rearward adjustment



To move the seat forward or rearward:

1. Pull up the seat slide adjustment lever [A] and hold it.
2. Slide the seat to the position you desire.
3. Release the lever and make sure the seat is locked in place.

Information

For the optimal safety, slide the rear seat to the rearmost position.

Seatback angle

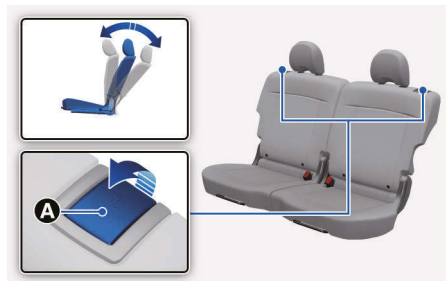

To recline the seatback:

1. Pull up the seatback recline lever [A].

2. Hold the lever and adjust the seatback of the seat to the position you desire.
3. Release the lever and make sure the seatback is locked in place. (The lever MUST return to its original position for the seatback to lock.)

Folding the seats

 if equipped

Folding the front seats

1. Locate the seat belt to each side.
2. Lower the headrest to the lowest position.
 - When folding down the driver seat, disassemble the headrest to avoid interference with the steering wheel.
 - When disassembling the headrest, recline the seatback with the seatback recline lever. Disassemble the headrest while pressing the unlock button on the headrest.
3. Pull the front lever located on the seat cushion and adjust the seat backward.
4. Lift the seatback angle lever [A] upward and fold the seatback forward. Make sure the seatback is locked in place.

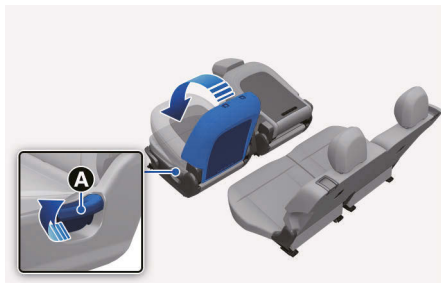

5. When using it as a seat, pull the angle lever to lift the seatback to the position you desire. The seat will be locked once you release the lever.

6. Lightly shake the seatback to check whether the seatback is firmly locked
 - When installing the headrest of a driver seat, use the seatback angle lever to recline the seatback. Install the headrest while pressing the unlock button of a headrest.

CAUTION

When folding the front seat to increase luggage capacity, make sure to turn off the seat warmer.

Folding the rear seats

The rear seatbacks can be folded to facilitate carrying long items or to increase the rear cargo volume in the vehicle.

WARNING

- Never allow passengers to sit on top of the folded down seatback while the vehicle is moving. This is not a proper seating position and no seat belts are available for use. This could result in serious injury or death in a collision or sudden stop.
- Objects carried on the folded down seatback should not extend higher than the top of the front seatbacks. This can allow cargo to slide forward and cause property damage or serious injury or even death during a collision or sudden stop.

To fold down the rear seatback:

1. Adjust the front seatback to the upright position and if necessary, slide the front seat forward.
2. Lower the rear headrests to the lowest position by pushing and holding the release button [A] and pushing down on the headrest.

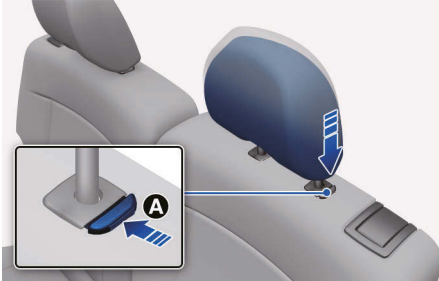

3. Route the seat belt webbing to the both sides of the rear seat to prevent the belts from being damaged.



4. Lift seatback angle lever [A] upward to fold the seatback forward. Make sure the seatback is locked in place.



5. Pull up the seatback folding lever [A], then fold the seat toward the front of the vehicle.



! WARNING

Lock the seatback properly. In a collision or sudden stop, an unlocked seatback may allow cargo to move forward with great force and may result in serious injury or death.

! WARNING

Cargo should always be secured to prevent it from moving in a collision and causing serious injury or death to the vehicle occupants. Do not place objects in the rear seats, because they cannot be properly secured and may hit the front seat occupants in a collision.

Headrest

The vehicle's front and rear seats have adjustable headrests. The headrests provide comfort for passengers, but more importantly they are designed to help protect passengers from whiplash and other neck and spinal injuries during an accident, especially in a rear impact collision. When there are no occupants in the rear seats, adjust the rear headrests to the lowest height to improve the driver's visibility.

WARNING

To reduce the risk of serious injury or death in an accident, take the following precautions when adjusting your headrests:

- Always adjust the headrests properly for all passengers BEFORE starting the vehicle.
- Never let anyone ride in a seat with the headrest removed or reversed.
- Adjust the headrests so that the middle of the headrest is at the same height as the top of the eyes.



- Never adjust the headrest position of the driver's seat when the vehicle is in motion.
- Adjust the headrest as close to the passenger's head as possible. Do not use a seat cushion that holds the body away from the seatback.
- Make sure the headrest locks into position after adjusting it.

WARNING

When passengers are sitting on the rear seats, always raise the headrests above the lowest stored position.

Front seat headrests



The driver's and front passenger's seats are equipped with adjustable headrests for the passengers safety and comfort.

Forward and rearward adjustment



The headrest may be adjusted forward to 3 different positions by pulling the headrest forward to the desired detent. To adjust the headrest to its furthest rearwards position, pull it fully forward to the farthest position and release it.

Adjusting the height up and down

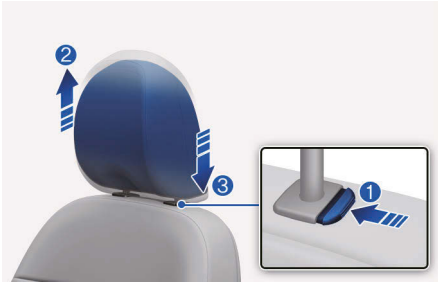

To raise the headrest:

1. Pull it up to the desired position (2).

To lower the headrest:

1. Press and hold the release button (1) on the headrest support.
2. Lower the headrest to the desired position (3).

NOTICE



If you recline the seatback towards the front with the headrest and seat cushion raised, the headrest may come in contact with the sunvisor or other parts of the vehicle.

Removal/Reinstall

To remove the headrest:



1. Recline the seatback (2) with the seatback angle lever or switch (1).
2. Pull up the headrest to the upmost position and press the release button (3) to remove the headrest (4).

⚠ WARNING

Never allow anyone to travel in a seat with the headrest removed.

To reinstall the headrest:



1. Recline the seat back by pressing seatback angle lever or switch (3).
2. Put the headrest poles (2) into the holes while pressing the release button (1).
3. Adjust the headrest to the appropriate height.
4. Adjust the seatback angle (4) with the seatback angle lever or switch (3).

WARNING

Always make sure the headrest locks into position after reinstalling and adjusting it properly.

Rear seat headrests



The rear seats are equipped with headrests in all the seating positions for the passenger's safety and comfort.

Adjusting the height up and down

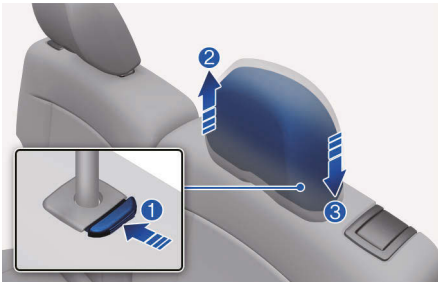

To raise the headrest:

1. Pull it up to the desired position (1).

To lower the headrest:

1. Press and hold the release button (2) on the headrest support.
2. Lower the headrest to the desired position (3).

Removal/Reinstallation

To remove the headrest:

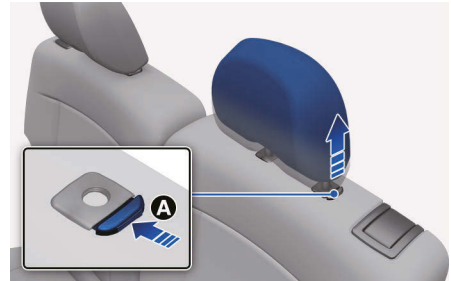

1. Raise the headrest as far as it can go.
2. Press the headrest release button [A] while pulling up the headrest.

To reinstall the headrest:

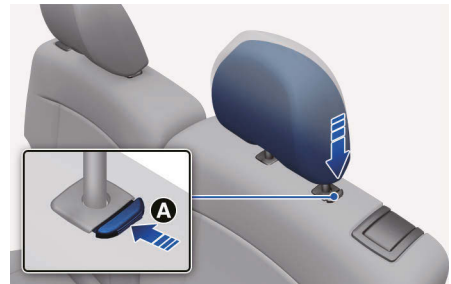

1. Press the seatback angle switch to recline the seatback forward.
2. Put the headrest poles into the holes while pressing the release button [A].
3. Adjust the headrest to the appropriate height.

Seats warmers

 If equipped

Seat warmers are provided to warm the seats during cold weather.

During mild weather or under conditions where the operation of the seat warmer is not needed, keep the seat warmers off.

WARNING

The seat warmers can cause a serious burns, even at low temperatures and especially if used for long periods of time. Passengers must be able to feel if the seat is becoming too warm so they can turn it off, if needed.

Seat warmers consumes huge amount of electricity. Please avoid using seat warmers while the vehicle is off in order to prevent the battery discharge.

People who cannot detect temperature change or pain to the skin should use extreme caution, especially the following types of passengers:

- Infants, children, elderly or disabled persons, or hospital outpatients.
- People with sensitive skin or who burn easily.
- Fatigued individuals.
- Intoxicated individuals.
- People taking medication that may cause drowsiness or sleepiness.

Never place anything on the seat that insulates against heat when the seat warmer is operating, such as a blanket or seat cushion.

NOTICE

To prevent damage to the seat warmers and seats:

- Never use a solvent such as paint thinner, benzene, alcohol or gasoline to clean the seats.

- Do not place heavy or sharp objects on seats equipped with seat warmers.
- Do not change the seat cover. It may damage the seat warmer.

Front seat warmers



While the vehicle is running, press the switch to warm the driver's seat or front passenger's seat.

- Pressing the switch each time changes the temperature in turn from high to low, and off.
- The seat warmer temperature is lowered automatically and then goes off after a certain time to prevent low temperature burns. If high temperature is selected again after the seat warmer turns off, the temperature is controlled automatically again.
- The seat warmer defaults to the OFF position whenever the Start/Stop button is pressed to the ON position.

Information

Select **Settings > Vehicle > Seat** from the settings menu in the infotainment system. You may use various convenience functions.

- **Warmer/Ventilation features**
Warmer/ventilation based on climate settings: The seat temperature is automatically controlled.

Air ventilation seats

+ if equipped

The air ventilation seats cool the front seats by blowing air through small vent holes on the surface of the seat cushions and seatbacks.

When the operation of the air ventilation seat is not needed, keep the air ventilation seats off.

NOTICE

To prevent damage to the air ventilation seats:

- Never use a solvent such as paint thinner, benzene, alcohol, or gasoline to clean the seats.
- Avoid spilling liquids on the surface of the front seats and seatbacks. This may cause the air vent holes to become blocked and not to work properly.
- Do not place materials such as plastic bags or newspapers under the seats. They may block the air intake causing the air vents not to work properly.
- Do not change the seat covers.
- If the air vents do not operate, restart the vehicle. If there is no change, we recommend that your vehicle be inspected by an authorized HYUNDAI dealer.

Front air ventilation seats



While the vehicle running, press the switch to cool the driver's seat or front passenger's seat.

- Press the button repeatedly to cycle through the airflow speeds from high to low, and off.

i Information

- It may take 3-5 minutes after switching operation to feel the temperature change.
- The air ventilation seat remains off once you turn off the vehicle.

However, if the Auto. Controls that use climate control setting function is on, the driver's seat air ventilation will turn on and off depending on the ambient temperature.

CAUTION

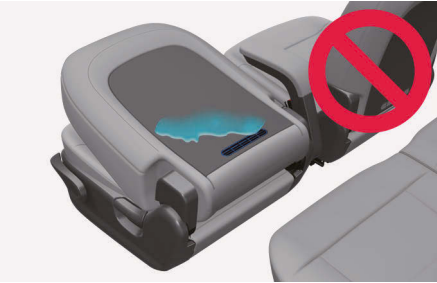

Avoid any foreign substances entering the rear air ventilation inlet when the front seatback is folded. This may damage the air ventilation system. Be careful not to spill your drink in the inlet.

Information

Select **Settings > Vehicle > Seat** from the settings menu in the infotainment system. You may use various convenience functions

- **Warmer/Ventilation features**
Warmer/ventilation based on climate settings: The seat temperature is automatically controlled.

Seat belts

This section describes how to use the seat belts properly. It also describes some of the things not to do when using seat belts.

Seat belt safety precautions

Always fasten your seat belt and make sure all passengers have fastened their seat belts before starting any trip. Airbags are designed to supplement the seat belt as an additional safety device, not a replacement. Most countries require all vehicle occupants to wear seat belts.

WARNING

Seat belts must be used by ALL passengers whenever the vehicle is moving. To prevent serious injury or death:

- Children under the age of 13 should be properly restrained in the rear seats.
- Never allow children to ride in the front passenger seat, unless the airbag is deactivated. If a child is seated in the front passenger seat, move the seat as far back as possible. And the child must always be restrained in the seat properly.
- NEVER allow an infant or child to be carried on an occupant's lap.
- NEVER ride with the seatback reclined when the vehicle is moving.
- Do not allow children to share a seat or seat belt.
- Do not wear the shoulder belt under your arm or behind your back.
- Do not use the seat belt if it is twisted. A twisted seat belt will not protect you properly in a collision.
- Do not use a seat belt if the webbing or hardware is damaged.

- Do not latch the seat belt into the buckles intended for other seating positions.
- Never unfasten the seat belt while driving. This may cause loss of vehicle control resulting in a collision.
- Make sure there is nothing in the buckle that could interfere with the seat belt latch mechanism from fastening securely.
- Never modify seatbelt or install devices that may prevent seatbelt assembly from removing slack.
- Do not use a seat belt if the webbing or hardware is damaged. We recommend that the seat belt be replaced by an authorized HYUNDAI dealer.

WARNING

Damaged seat belts and seat belt assemblies do not operate properly. Always replace:

- Frayed, contaminated, or damaged webbing.
- Damaged hardware.
- The entire seat belt assembly after it has been worn in an accident, even if damage to webbing or assembly is not apparent.

Seat belt warning light

Driver's seat belt warning

Instrument cluster



As a reminder to the driver, the driver's seat belt warning lights illuminates for about 6 seconds each time the Start/Stop button is in the ON position regardless of seatbelt fastening.

If continue not to fasten the seat belt or unfasten the seat belt while driving under 20 km/h (12 mph), the seat belt warning light illuminates.

If you continue not to fasten the seat belt or unfasten the seat belt while driving 20 km/h (12 mph) or faster, the seat belt warning chime sounds for certain period of time and the warning light blinks.

Front passenger's seat belt warning

As a reminder to the front passenger, the front passenger's seat belt warning lights illuminates for about 6 seconds each time the Start/Stop button is turned on regardless of seatbelt fastening.

If the passenger continues to not fasten their seat belt or unfasten their seat belt and you drive under 20 km/h (12 mph), the seat belt warning light illuminates.

If the passenger continues to not fasten their seat belt or unfasten their seat belt and you drive 20 km/h (12 mph) or faster, the seat belt warning chime sounds for certain period of time and the corresponding warning light blinks.

WARNING

Riding in an improper position may adversely affect the front passenger's seat belt warning system. Instruct the passenger to properly be seated when the vehicle is moving.

Information

- If the front passenger seat is not occupied, the seat belt warning light blinks or illuminate for 6 seconds.
- The front passenger's seat belt warning may operate when luggage is placed on the front passenger seat.

Rear passenger's seat belt warning



- As a reminder to the rear passenger, the rear passenger's seat belt warning lights will illuminate for approximately 6 seconds each time the Start/Stop button is in the ON position regardless of belt fastening.
- If the seat belt is not fastened when the Start/Stop button is turned on, the seat belt warning light will illuminate for approximately 70 seconds.
- If you start to drive without the seat belt fastened or you unfasten the seat belt when you drive under 20 km/h (12 mph), the corresponding warning light will continue to illuminate for approximately 70 seconds.

- If you continue to drive without the seat belt fastened or you unfasten the seat belt when you drive over 20 km/h (12 mph), the seat belt warning chime will sound for approximately 35 seconds and the corresponding warning light will blink.

Seat belt restraint system

Lap/shoulder belt

To fasten your seat belt:

1. Pull the belt out of the retractor and insert the metal tab into the buckle (1). There An audible "click" sounds when the tab locks into the buckle. Make sure the seat belt is not twisted.
2. Place the lap belt (2) portion across your hips and the shoulder belt (3) portion across your chest.
3. Adjust the height of the shoulder belt anchor to the height of your shoulder.
 - To raise the height adjuster, pull it up.
 - To lower it, put it down while pressing the height adjuster button [A].

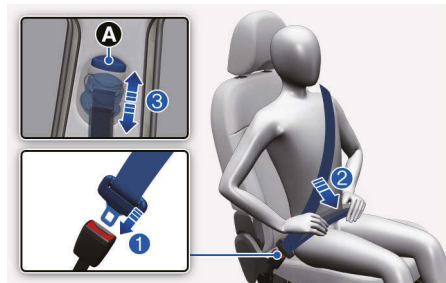

The seat belt automatically adjusts to the proper length after the lap belt portion is adjusted manually so that it fits snugly around your hips. If you lean forward in a slow, easy motion, the belt extends and moves with you.

If there is a sudden stop or impact, the belt will lock into position. It will also lock if you try to lean forward too quickly.

NOTICE

If you cannot smoothly pull the seat belt out from the retractor, firmly pull the seat belt out and release it. After release, the belt may be pulled out smoothly.

⚠ WARNING

Improperly positioned seat belts may increase the risk of serious injury in an accident. Take the following precautions when adjusting the seat belt:

- Position the lap portion of the seat belt as low as possible across your hips, not on your waist, so that it fits snugly. This allows your strong pelvic bones to absorb the force of the crash, reducing the chance of internal injuries.
- Position one arm under the shoulder belt and the other over the belt, as shown in the illustration.
- Always position the shoulder belt anchor into the locked position at the appropriate height.
- Never position the shoulder belt across your neck or face.

Height adjustment

Adjust the height of the shoulder belt so that it lies across your chest and midway over your shoulder nearest the door, not over your neck.

To adjust the height of the seat belt anchor:

- Pull it up (1) to raise the height. To lower it, push it down (2) while pressing the height adjuster button [A]. Release the button to lock the anchor in place. Try pushing the height adjuster down to make sure that it is locked in place.

Front seat

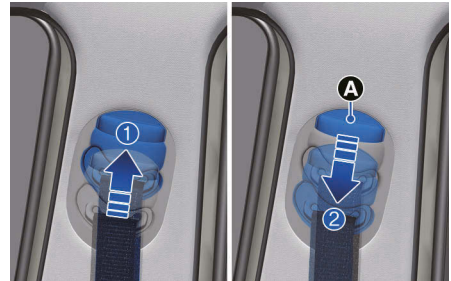

i Information

Rear seat belt



The buckles of rear seats are stored in the seat cushions.

- To use the seatbelt, take out the buckles.
- Be careful not to be confused with the other buckles.
- Restore the buckle between the seatback cushions after unfastening the seatbelt.
- If you cannot pull the seatbelt, pull the belt hard, release it, then pull it again.
- To prevent the metal plate from hitting the window, hold the plate and slowly retract the seatbelt.

To release your seat belt:

Press the release button [A] in the locking buckle.

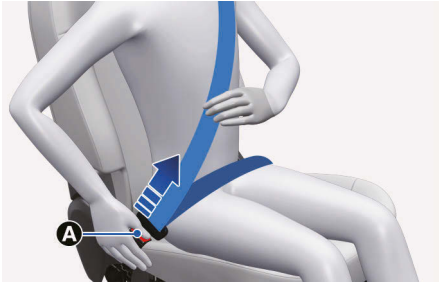

Once released, the belt should automatically draw back into the retractor. If this does not happen, check the belt to be sure it is not twisted, then try again.

Pretensioner seat belt

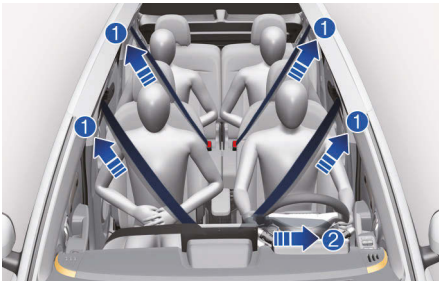

- (1) Retractor pretensioner seat belt
- (2) Emergency Fastening Device (EFD)

Your vehicle is equipped with driver's, front and rear side passenger's pretensioner seat belts (retractor pretensioner). The pretensioner makes sure the seat belts fit tightly against your body in certain frontal or side collision(s). The pretensioner seat belts may be activated in some crashes where the frontal or side collision(s) is severe enough, together with the airbags.

When the vehicle stops suddenly, or if the occupant tries to lean forward too quickly, the seat belt retractor will lock into position. In certain frontal or side collision(s), the pretensioner will activate and pull the seat belt into tighter contact against the occupant's body.

(1) Retractor Pretensioner

The purpose of the retractor pretensioner is to make sure that the shoulder belts fit in tightly against the occupant's upper body in certain frontal or side collision(s).

(2) Emergency Fastening Device System

The purpose of the Emergency Fastening Device System is to make sure that the pelvis belts fit in tightly against the occupant's lower body in certain frontal or side collision(s).

If the system senses excessive tension on the driver or passenger's seat belt when the pretensioner system activates, the load limiter inside the retractor pretensioner will release some of the pressure on the affected seat belt. (if equipped with load limiter).

WARNING

To prevent serious injury or death:

- Always wear your seat belt and sit properly in your seat.
- Do not use the seat belt if it is loose or twisted.
- Do not place anything near the buckle.
- Always replace your pretensioners after activation or an accident.
- NEVER inspect, service, repair or replace the pretensioners by yourself. We recommend that the pretensioners be inspected, serviced, repaired, or replaced by an authorized HYUNDAI dealer.
- Do not hit the seat belt assemblies.

⚠ WARNING

Do not touch the pretensioner seat belt assemblies for several minutes after they have been activated. When the pretensioner seat belt mechanism deploys during a collision, the pretensioner can become hot and can burn you.

⚠ CAUTION

Body work on the front area of the vehicle may damage the pretensioner seat belt system. Therefore, we recommend the system to be serviced by an authorized HYUNDAI dealer.

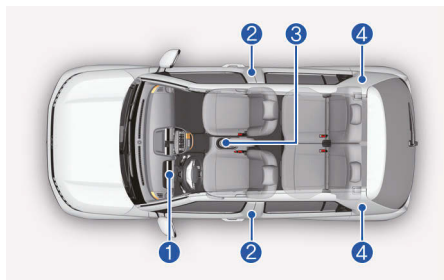

The pretensioner seat belt system consists mainly of the following components. Their locations are shown in the illustration above:

- (1) SRS airbag warning light
- (2) Front retractor pretensioner
- (3) SRS control module
- (4) Rear retractor pretensioner

NOTICE

The sensor that activates the SRS control module is connected with the pretensioner seat belt. The SRS airbag warning light on the instrument cluster illuminates for about 3-6 seconds after the Start/Stop button is in the ON position, and then turns off.

If the pretensioner is not working properly, the warning light illuminates even if the SRS airbag is not malfunctioning. If the warning light does not illuminate when starting the vehicle or stays illuminated while driving, we recommend the pretensioner seat belts and/or SRS control module be inspected by an authorized HYUNDAI dealer as soon as possible.

i Information

- Pretensioner seat belts may be activated in certain frontal or side collisions or rollover situations.
- When the pretensioner seat belts are activated, a loud noise may be heard and fine dust, which may appear to be smoke, may be visible in the passenger compartment. These are normal operating conditions and are not hazardous.
- Although it is non-toxic, the fine dust may cause skin irritation and should not be inhaled for prolonged periods. Wash all exposed skin areas thoroughly after an accident in which the pretensioner seat belts were activated.

Additional seat belt safety precautions**Seat belt use during pregnancy**

The seat belt should always be used during pregnancy. The best way to protect your unborn child is to protect yourself by always wearing the seat belt.

Pregnant women should always wear a lap-shoulder seat belt. Place the shoulder belt across your chest, routed between your breasts and away from your neck. Place the lap belt below your belly and pull the shoulder portion so that it fits **SNUGLY** across your hips and pelvic bone, under the rounded part of your belly.

WARNING

- Pregnant women and patients are more vulnerable to any impacts on the abdomen during an abrupt stop or collision. If you are in an accident while pregnant, consult your doctor.
- To reduce the risk of serious injury or death to an unborn child during an accident, pregnant women should NEVER place the lap portion of the seat belt above or over the area of the abdomen where the unborn child is located.

Seat belt use and children

Infant and small children

Most countries have Child Restraint System laws that require children to travel in approved Child Restraint System devices, including booster seats. The age at which seat belts can be used instead of Child Restraint System may be different among countries, so you should be aware of the specific requirements in your country, and where you are travelling. Infant and Child Restraint System must be properly placed and installed in a rear seat.

For more information refer to the "Seat belt safety precautions" section in this chapter.

WARNING

Always properly restrain infants and small children in a Child Restraint System appropriate for the child's height and weight.

To reduce the risk of serious injury or death to a child and other passengers, never hold a child in your lap or arms when the vehicle is moving. Violent forces during a collision may tear the child from your arms and throw the child against the interior or to be ejected from the vehicle.

Small children are best protected from injury in an accident when properly restrained in the rear seat by a Child Restraint System that meets the requirements of the Safety Standards of your country. Before buying any Child Restraint System, make sure that it has a label certifying that it meets the applicable Safety Standards.

The Child Restraint System must be appropriate for your child's height and weight. Check the label on the Child Restraint System for this information. Refer to the "Child Restraint System (CRS)" section in this chapter.

Larger children

Children under age 13 and who are too large for a booster seat should always occupy the rear seat and use the available lap/shoulder belts. A seat belt should be snug against the hips and be snug across the shoulder and chest to restrain the child safely. A child's squirming could move the belt out of position. Adults should frequently check belt fit. In a collision, the safest place for children is in the rear seats, using a Child Restraint System appropriate for the child.

If a larger child over age 13 must be seated in the front seat, the child must be securely restrained by the available seat belt and the seat should be placed in the rearmost position.

If the shoulder belt portion slightly touches the child's neck or face, try placing the child closer to the center of the vehicle. If the shoulder belt still touches their face or neck, the child needs to return to an appropriate booster seat in the rear seat.

WARNING

- Always make sure larger children's seat belts are buckled and properly adjusted.
- Never allow the shoulder belt to contact the child's neck or face.
- Do not allow more than one child to use a single seat belt.

Seat belt use and injured people

A seat belt should still be used when an injured person is being transported. Consult a physician for specific recommendations.

One person per belt

When two people (children or adults) are sitting together, never attempt to use a single seat belt. This could increase the severity of injuries in a collision.

Do not lie down

Sitting in a reclined position when the vehicle is moving can be dangerous. Even when buckled up, the protections of your restraint system (seat belts and/or airbags) is greatly reduced by reclining your seatback.

Seat belts must be snug against your hips and chest to work properly.

During a collision, you could be thrown into the seat belt, causing neck or other injuries.

The more the seat back is reclined, the greater the chance for the passenger's hips to slide under the lap belt or the passenger's neck to strike the shoulder belt.

WARNING

- Never ride with a reclined seatback when the vehicle is moving.
- Riding with a reclined seatback increases your chance of serious or fatal injuries in the event of a collision or sudden stop.
- Driver and passengers should always sit well back in their seats with the seatbacks upright and should be belted properly.

Care of seat belts

Seat belt systems should never be disassembled or modified.

Periodic inspection

All seat belts should be inspected periodically for wear or damage of any kind. Any damaged parts should be replaced as soon as possible.

Keep belts clean and dry

Seat belts should be kept clean and dry. If belts become dirty, they can be cleaned by using a mild soap solution and warm water. Bleach, dye, strong detergents, or abrasives should not be used because they may damage and weaken the fabric.

When to replace seat belts

The entire seat belt assembly or assemblies should be replaced if the vehicle has been involved in an accident. This should be done even if no damage is visible. We recommend that you consult an authorized HYUNDAI dealer for assistance.

Child Restraint System (CRS)

Our recommendation: Children always in the rear

WARNING

Always properly restrain children in the vehicle. Children of all ages are safer when riding in the rear seats. Never place a rearward-facing Child Restraint System on the front passenger seat, unless the airbag is deactivated.

Children under age 13 should always ride in the rear seats and must always be properly restrained to minimize the risk of injury in a collision, sudden stop, or sudden maneuver.

According to accident statistics, children are safer when properly restrained in the rear seat than in the front seat. Children too large for a Child Restraint System must use the seat belts provided.

Most countries have child restraint regulations that require children to travel in approved Child Restraint Systems.

The laws governing the age or height/weight restrictions at which seat belts can be used instead of Child Restraint System differs among countries, so you should be aware of the specific requirements where you are travelling.

Child Restraint Systems must be properly installed in the vehicle seat. Use a commercially available Child Restraint System that meets the requirements of the Safety Standards of your country.

Child Restraint Systems are generally designed to be secured in a vehicle seat by a lap/shoulder seat belt, or by a top tether and/or ISOFIX anchorage in the rear seats of the vehicle.

Child Restraint System

Infants and younger children must be restrained in an appropriate rearward-facing or forward-facing Child Restraint System that has first been properly secured to the seats of the vehicle. Read and comply with the instructions for installation and use provided by the manufacturer of the Child Restraint System.

WARNING

Do not use an improperly secured Child Restraint System. It may increase the risk of serious injury or death in a collision. When using a Child Restraint System:

- Always follow the Child Restraint System manufacturer's instructions for installation and use.
 - Always properly restrain your child in the Child Restraint System.
 - Do not use an infant carrier or a child safety seat that "hooks" over a seatback. It may not provide adequate protection in an accident.
 - After an accident, we recommend that your vehicle be inspected by an authorized HYUNDAI dealer to check the Child Restraint System, seat belts, ISOFIX anchorages, and top tether anchorages.
-

Selecting a Child Restraint System (CRS)

When selecting a Child Restraint System for your child, always:

- Make sure the Child Restraint System has a label certifying that it meets applicable Safety Standards of your country.
A Child Restraint System may only be installed if it was approved in accordance with the requirements of ECE-R44 or ECE-R129.
- Select a Child Restraint System based on your child's height and weight. The required label or the instructions for use typically provide this information.
- Select a Child Restraint System that fits the vehicle seating position where it is to be used.
- Read and comply with the warnings and instructions for installation and use provided with the Child Restraint System.

Child Restraint System types

There are three main types of Child Restraint Systems: rearward-facing, forward-facing, and booster seat Child Restraint Systems.

They are classified according to the child's age, height, and weight.

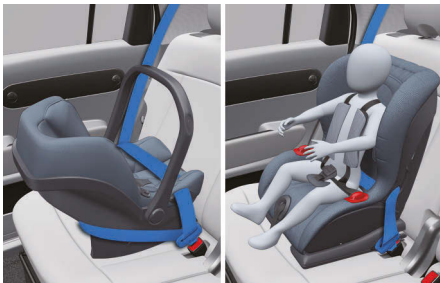

Rearward-facing Child Restraint System

With a rearward-facing Child Restraint System, the collision forces are absorbed by its shell instead of the child's body. The shell also supports the system's cradles and protects the head, neck and spine of the child. All children under the age of one year must always ride in a rearward-facing Child Restraint System. Convertible and 3-in-1 Child Restraint Systems typically have higher height and weight limits for the rearward-facing position, allowing you to keep your child rearward-facing for a longer period of time.

Continue using the Child Restraint Systems in the rearward-facing position as long as the child is within the height and weight limits allowed by the Child Restraint System's manufacturer. It's the best way to keep them safe. Once your child has outgrown the rearward-facing Child Restraint System, your child is ready for a forward-facing Child Restraint System with a harness.

Forward-facing Child Restraint System

A forward-facing Child Restraint System provides restraint for the child's body with a harness. Keep children in a forward-facing Child Restraint System with a harness until they reach the top height or weight limit allowed by your Child Restraint System's manufacturer.

Once your child outgrows the forward-facing Child Restraint System, your child is ready for a booster seat.

Booster seats

A booster seat is a Child Restraint System designed to improve the fit of the vehicle's seat belt system. A booster seat positions the seat belt so that it fits properly over the stronger parts of your child's body. Keep your children in booster seats until they are big enough to fit in a seat belt properly.

For a seat belt to fit properly, the lap belt must lie snugly across the upper thighs, not the stomach. The shoulder belt should lie snug across the shoulder and chest and not across the neck or face. Children under age 13 must always be properly restrained to minimize the risk of injury in an accident, sudden stop, or sudden maneuver.

Installing a Child Restraint System

WARNING

Before installing your Child Restraint System, always read and follow the instructions provided by the manufacturer of the Child Restraint System and in this manual to prevent serious injury or death if a collision occurs.

WARNING

If the vehicle headrest prevents proper installation of a Child Restraint System (as described in the Child Restraint System manual), readjust or remove the headrest for that seating position.

After selecting a proper Child Restraint System for your child and checking that the Child Restraint System fits properly in a seating position, there are three general steps for a proper installation:

- **Properly secure the Child Restraint System to the vehicle.** All Child Restraint Systems must be secured to the vehicle with a lap/shoulder belt or with an ISOFIX top tether and/or ISOFIX anchorage and/or with a support leg.
- **Make sure the Child Restraint System is firmly secured.** After installing a Child Restraint System to the vehicle, push and pull the seat forwards and backwards and from side to side to verify that it is securely attached to the seat. A child restraint secured with a seat belt should be installed as firmly as possible. However, Some side-to-side movement can be expected.
- **Secure the child in the Child Restraint System.** Make sure the child is properly strapped in the Child Restraint System according to the Child Restraint System manufacturer's instructions.

CAUTION

Check the seating surface and buckles before placing your child in the Child Restraint System to prevent burns. A Child Restraint System in a closed vehicle can become very hot.

Suitability of each seating position for belted & ISOFIX Child Restraint Systems according to UN regulations

(Information for vehicle users and CRS manufacturers)

- Yes: Suitable for fitment of the designated category of CRS.
- No: Not suitable for fitment of the designated category of CRS.
- -: Not applicable.
- The table is based on left-hand drive vehicle. Except for the front passenger seat, the table is valid for right-hand drive vehicle. For right-hand drive vehicle front passenger seat, use information for the seating position number 3.

CRS categories		Seating positions				
		1,2	3		4	5
			Airbag ON	Airbag OFF		
Universal belted CRS	All mass groups	-	No	Yes ^{*1} F, R	Yes F, R	Yes F, R
i-size CRS	ISOFIX CRF: F2, F2X, R1, R2	-	No	No	Yes F, R	Yes F, R
Carry-cot (ISOFIX lateral facing CRS)	ISOFIX CRF: L1, L2	-	No	No	No	No
ISOFIX infant* CRS (*: ISOFIX baby CRS)	ISOFIX CR: R1	-	No	No	Yes R	Yes R
ISOFIX toddler CRS - small	ISOFIX CRF: F2, F2X, R2, R2X	-	No	No	Yes F, R	Yes F, R
ISOFIX toddler CRS - large* (*: not booster seats)	ISOFIX CRF: F3, R3	-	No	No	Yes F, R	Yes F, R
Booster Seat - reduced width	ISO CRF: B2	-	No	No	Yes	Yes
Booster Seat - full width	ISO CRF: B3	-	No	No	Yes	Yes

*1 To install Universal CRS, 1st row passenger seat should be adjusted to the appropriate position which do not interfere with stable installation (adjust to possible height or upright position)

i Information

F: Forward facing, R: Rearward facing

i Information

- If the vehicle headrest prevents proper installation of a CRS, the headrest of the seating position shall be readjusted or entirely removed.
- Never place a rearward facing Child Restraint System on the front passenger seat, unless the airbag is deactivated.
- For semi-universal or vehicle specific CRS (ISOFIX or belted CRS), please see the vehicle list provided in the manual of CRS.
- When Installing Child Restraint system on 2nd row seats, move the seat to mid-position.

i Information

- If the headrests prevent proper installation of a CRS, the headrests of the seating position shall be readjusted or entirely removed
- Never place a rearward facing Child Restraint System on the front passenger seat, unless the airbag is deactivated.

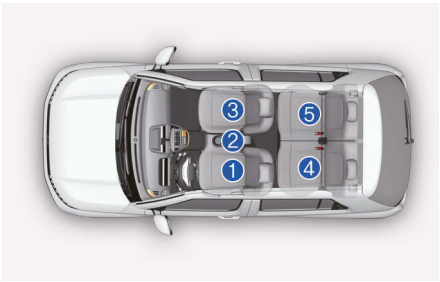
Seat number	Position in the vehicle	Seating positions
1	Front left	
2	Front center	
3	Front right	
4	2nd row left	
5	2nd row right	

Recommended Child Restraint Systems

Child Height	Name	Manufacturer	Type of Fixation
40 – 83 cm	BABY-SAFE 3 i-Size with FLEX BASE i-Sense	Britax	ISOFIX with supported leg (RWF)
76 – 105 cm	Trifix2 i-Size	Britax	ISOFIX mounted with top-tether
100 – 150 cm	Solution T i-Fix	Cybex	ISOFIX
135 – 150 cm	Booster Basic R129	Graco	Vehicle Belt

CRS Manufacturer information

Britax: <https://www.britax-roemer.com/>

Cybex: <https://www.cybex-online.com/>

Graco: <https://www.graco.com>

ISOFIX anchorage and top tether anchorage (ISOFIX anchorage system) for children

The ISOFIX system connects a Child Restraint System to the vehicle during driving and in a collision. This system is designed to make installation of the Child Restraint System easier and reduce the possibility of improperly installing your Child Restraint System. The ISOFIX system uses anchors in the vehicle and attachments on the Child Restraint System. The ISOFIX system eliminates the need to use seat belts to secure the Child Restraint System to the rear seats.

ISOFIX anchorages are metal bars built into the vehicle. There are two lower anchors for each ISOFIX seating position that accommodates a Child Restraint System with lower attachments.

To use the ISOFIX system in your vehicle, install a Child Restraint System with ISOFIX attachments. (An ISOFIX Child Restraint System may only be installed if it has vehicle specific or universal approval in accordance with the requirements of ECE-R44 or ECE-R129.)

The Child Restraint System manufacturer provides you with instructions on how to use the Child Restraint System with its attachments for the ISOFIX anchorages.

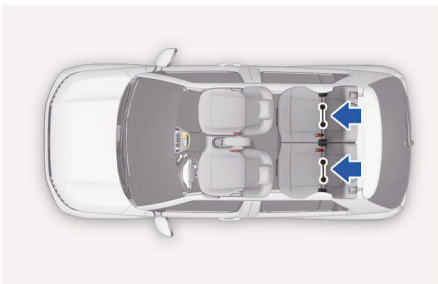

ISOFIX anchorages have been provided in the left and right outboard rear seating positions. Their locations are shown in the illustration.

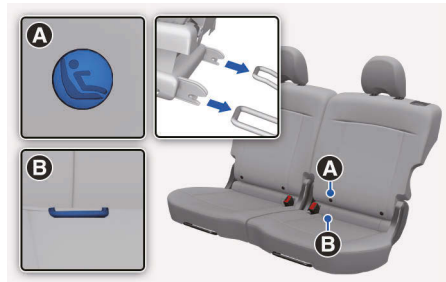

[A] ISOFIX anchorage position indicator (☉)
[B] ISOFIX anchorage

The ISOFIX anchorage position indicator symbols are located on the left and right rear seatbacks to identify the positions of the lower anchors in your vehicle.

Both rear outboard seats are equipped with a pair of ISOFIX anchorages as well as a corresponding top tether anchorage on the back side of the rear seats.

(Child Restraint Systems with universal approval according to ECE-R44 or ECE-R129 need to be fixed additionally with a top tether connected to the back side of the rear seats.)

The ISOFIX anchorages are located between the seatback and the seat cushion of the rear seat left and right outboard seating positions.

⚠ WARNING

Before installing the Child Restraint System, make sure that there are no objects (for example, toys, pens, wires) near the ISOFIX anchorage area. Those objects may damage either the seat belt system or the Child Restraint System during installation. If necessary, we recommend that the vehicle be inspected by an authorized HYUNDAI dealer.

Securing a Child Restraint System with the ISOFIX Anchorage System

To install an i-Size or ISOFIX-compatible Child Restraint System in either of the rear outboard seating positions:

1. Move the seat belt buckle away from the ISOFIX anchorages.
2. Move any other objects away from the anchorages that could prevent a secure connection between the Child Restraint System and the ISOFIX anchorages.
3. Place the Child Restraint System on the vehicle seat, then attach the seat to the ISOFIX anchorages according to the instructions provided by the Child Restraint System manufacturer.
4. Follow the instructions of the Child Restraint System's manufacturer for proper installation and connection of the ISOFIX attachments on the Child Restraint System to the ISOFIX anchorages.

WARNING

Take the following precautions when using the ISOFIX system:

- Read and follow all installation instructions provided with your Child Restraint System.
 - To prevent the child from reaching and taking hold of unretracted seat belts, buckle all unused rear seat belts and retract the seat belt webbing behind the child. The child can be strangled if a shoulder belt becomes wrapped around their neck and the seat belt tightens.
 - Never attach more than one Child Restraint System to a single anchorage. This may cause the anchorage or attachment to come loose or break.
 - Always have the ISOFIX system inspected by your dealer after a collision. A collision can damage the ISOFIX system and may not properly secure the Child Restraint System.
-

Securing a Child Restraint System seat with Top Tether Anchorage system

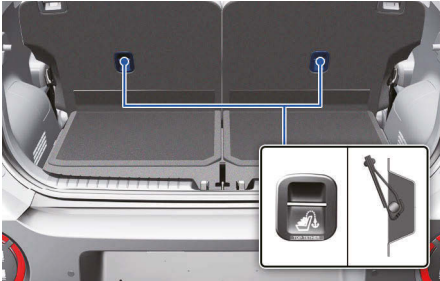

First secure the child restraint with the ISOFIX anchorages or the seat belt. If the child restraint manufacturer recommends that the top tether strap be attached, attach and tighten the top tether strap to the top tether strap anchorage.

Top tether anchorages are located on the rear of the seatbacks.



To install the top tether anchor:

1. Route the Child Restraint System top tether strap over the seatback. Route the tether strap under the headrest and between the headrest posts, or route the top tether strap over the top of the vehicle seatback. Make sure the strap is not twisted.

2. Connect the top tether strap hook to the top tether anchorage, then tighten the top tether strap according to the instructions of your Child Restraint System's manufacturer to firmly secure the Child Restraint System.
3. Check the Child Restraint System is secure by pushing and pulling the seat forward and back and side-to-side.

WARNING

Take the following precautions when installing the top tether anchorage:

- Read and follow all installation instructions provided with your Child Restraint System.
- Never attach more than one Child Restraint System to a single ISOFIX top tether anchorage. This could cause the anchorage or attachment to come loose or break.
- Only attach the top tether strap to the correct top tether anchorage for that seating position.
- Child Restraint System anchorages are designed to withstand only those loads imposed by correctly fitted Child Restraint System.

Under no circumstances are they to be used for adult seat belts or harnesses or for attaching other items or equipment to the vehicle.

Securing a Child Restraint System with a lap/shoulder belt

When not using the ISOFIX system, all Child Restraint Systems must be secured to a rear seat using the lap/shoulder belt.



Installing a Child Restraint System with a lap/shoulder belt

To install a Child Restraint System on the rear seats:

1. Place the Child Restraint System on a rear seat and route the lap/shoulder belt around or through the Child Restraint System, following the Child Restraint System manufacturer's instructions. Make sure the seat belt webbing is not twisted.
2. Fasten the lap/shoulder belt latch into the buckle. Listen for the distinct "click" sound.



***i* Information**

Position the release button so that it is easy to access in an emergency.

3. Remove as much slack from the belt as possible by pushing down on the Child Restraint System while feeding the shoulder belt back into the retractor.
4. Push and pull on the Child Restraint System to confirm that the seat belt is holding it firmly in place.



If your Child Restraint System manufacturer instructs or recommends you to use a top tether anchorage with the lap/shoulder belt, refer to "Securing a Child Restraint System seat with Top Tether Anchorage system" section for more information.

To remove the Child Restraint System, press the release button on the buckle and then pull the seat belt out of the Child Restraint System and allow the seat belt to retract fully.

Airbag - supplemental restraint system

Left-hand drive

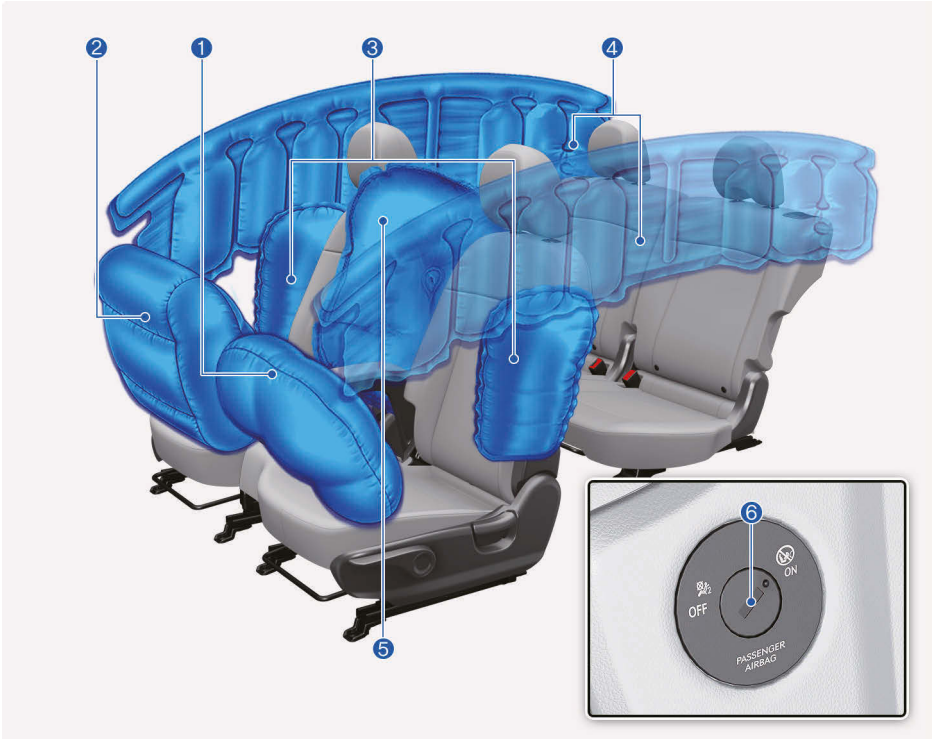

The actual airbags in the vehicle may differ from the illustration.

- (1) Driver's front airbag
- (2) Passenger's front airbag
- (3) Side airbag
- (4) Curtain airbag
- (5) Front center side airbag
- (6) Passenger's airbag ON/OFF switch (if equipped)

Right-hand drive

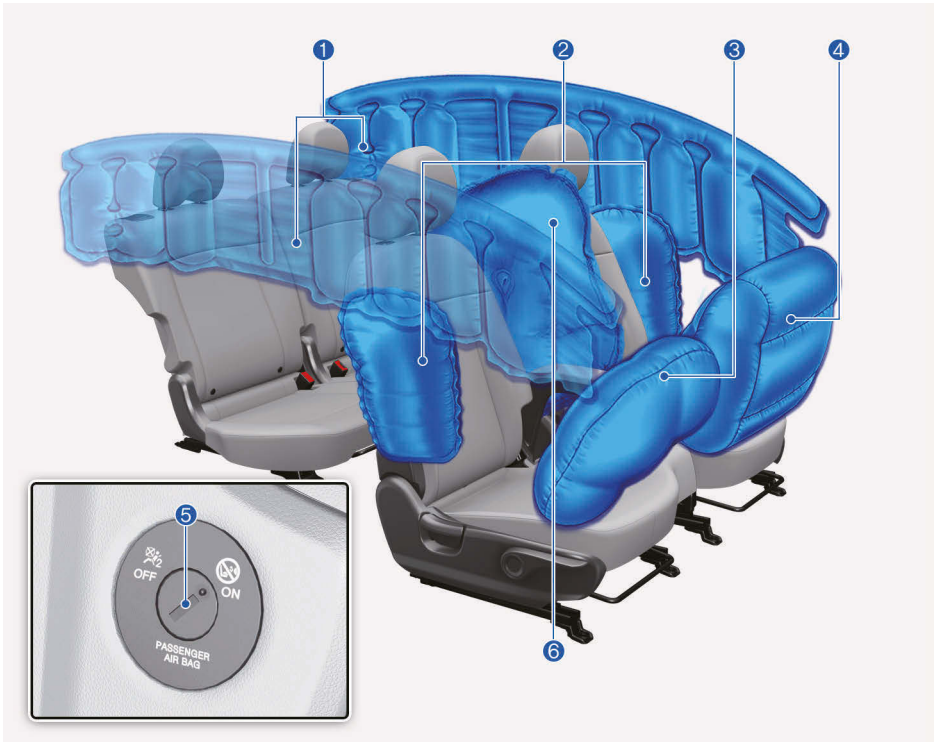

The actual airbags in the vehicle may differ from the illustration.

- (1) Curtain airbag
- (2) Side airbag
- (3) Driver's front airbag
- (4) Passenger's front airbag
- (5) Passenger's airbag ON/OFF switch (if equipped)
- (6) Front center side airbag

Your vehicle is equipped with a Supplemental Airbag System for the driver's and front passenger's seats.

The front airbags are designed to supplement the three-point seat belts. For these airbags to provide protection, seat belts must be properly worn at all times when driving.

You can be severely injured or killed in an accident if you are not wearing a seat belt.

Airbags are built into the vehicle as a supplementary system. They are not intended as a replacement for wearing 3-point seat belts. Also, airbags are not designed to deploy in every collision. In some accidents, the seat belts are the only restraint protecting you.



WARNING

AIRBAG SAFETY PRECAUTIONS

- Always use seat belts Child Restraint Systems - every trip, every time, everyone! Even with airbags, you can be seriously injured or killed in a collision if you are improperly belted or not wearing your seat belt when the airbag inflates.
 - Never place a child in any Child Restraint System or booster seat in the front passenger seat, unless the airbag is deactivated. An inflating airbag could forcefully strike the infant or child causing serious or fatal injuries.
 - ABC - Always Buckle Children under age 13 in the back seat. It is the safest place for children of any age to ride. If a child age 13 or older must be seated in the front seat, he or she must be properly belted and the seat should be moved as far back as possible.
 - Make sure that all occupants sit upright with the seatback in an upright position, centered on the seat cushion with their seat belt on, legs comfortably extended, and their feet on the floor until the vehicle is parked and the vehicle is turned off. If an occupant is out of position during an accident, the rapidly deploying airbag may forcefully contact the occupant causing serious or fatal injuries.
 - Never sit or lean unnecessarily close to the airbags or lean against the door or center console.
 - Move your seat as far back as possible from front airbags, while still maintaining control of the vehicle.
-

SRS Components

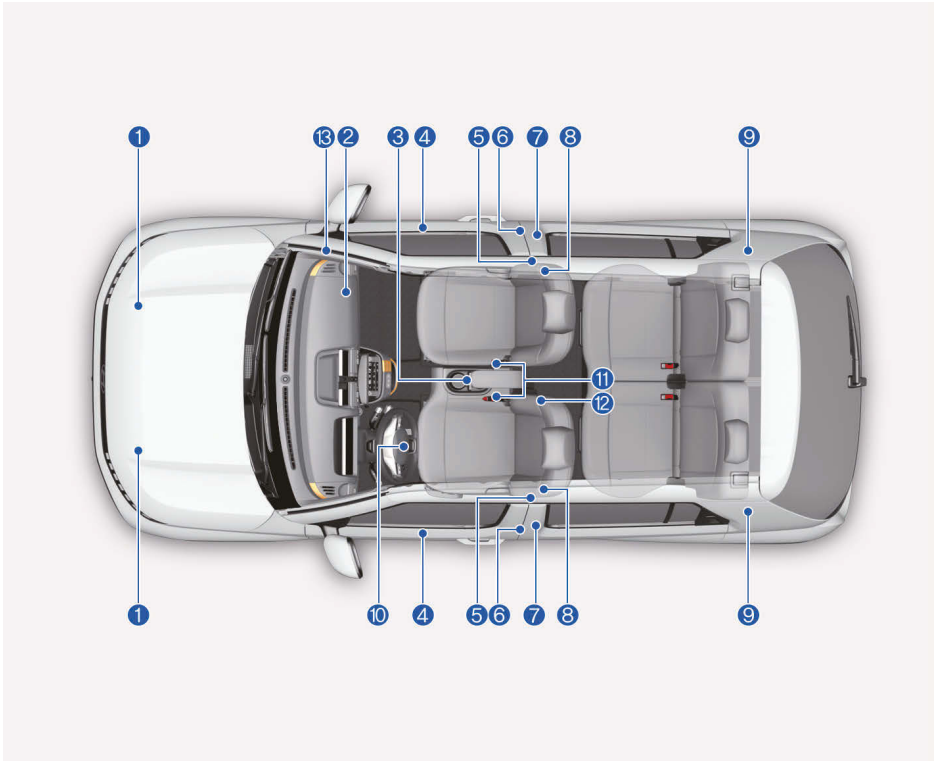

The SRS consists of the following components:

- (1) Front impact sensors
- (2) Passenger's front airbag module
- (3) SRS control module (SRSCM) / Rollover sensor
- (4) Side impact sensors (pressure)
- (5) Curtain airbag modules
- (6) Front retractor pretensioner
- (7) Side impact sensors (acceleration)
- (8) Side airbag modules
- (9) Rear retractor pretensioner
- (10) Driver's front airbag module
- (11) Driver's and front passenger's seat belt buckle sensors
- (12) Front center side airbag module
- (13) Front passenger's airbag ON/OFF switch (if equipped)

i Information

Front Passenger's airbag ON/OFF indicator is located on the center of the dashboard.

Where are the airbags?

Driver's and passenger's front airbags

Driver's front airbag



Passenger's front airbag

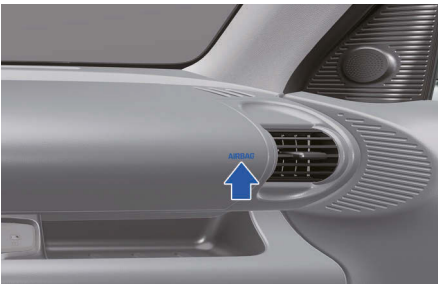

The SRS consists of airbags located in the center of the steering wheel and the passenger's side front panel pad above the glove box.

The airbag locations are embossed with the letters, "AIRBAG".

The purpose of the SRS is to provide the vehicle's driver and front passenger with additional supplemental protection that the seat belt system does not provide in case of a frontal impact of sufficient severity.

WARNING

To reduce the risk of serious injury or death from inflating front airbags:

- Seat belts must be worn at all times to help keep occupants positioned properly.
- Move your seat as far back as possible from front airbags, while still maintaining control of the vehicle.
- Never lean against the door or center console.
- Hold the steering wheel at the 9 o'clock and 3 o'clock positions, to minimize the risk of injuries to your hands and arms.
- Do not allow the front passenger to place their feet or legs on the dashboard.
- Never place any objects (such as dashboard cover, mobile phone holder, cup holder, perfume or stickers) over or near the airbag modules on the steering wheel, instrument panel, windshield glass, and the front passenger's panel above the glove box. Such objects may cause harm if the vehicle is in a crash severe enough to cause the airbags to deploy.
- Do not attach any objects on the front windshield and inside mirror.

Passenger's front airbag ON/OFF switch

+ if equipped

The purpose of the switch is to disable the passenger's front airbag to help reduce the risk of injury or death from an inflating airbag to certain front passenger seat occupants due to age, size, or medical condition.

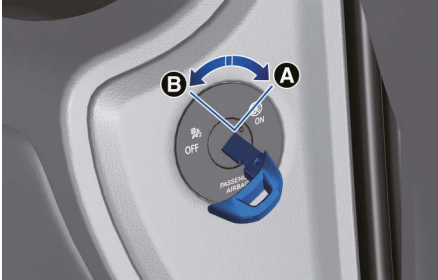

[A] Passenger airbag ON
[B] Passenger airbag OFF



Insert the key or a similar rigid device into the passenger's front airbag ON/ OFF switch and turn it to the OFF position [B]. The passenger airbag OFF indicator (Ⓞ) illuminates and stays on until the passenger's front airbag is reactivated.

To reactivate the passenger's front airbag:



Insert the key or a similar rigid device into the passenger's front airbag ON/OFF switch and turn it to the ON position [A]. The passenger airbag ON indicator (Ⓞ) illuminates.

i Information

The passenger's front airbag ON/OFF indicator illuminates for about 4 seconds after the Start/Stop button is in the ON position [A]. If the Start/Stop button is pressed to the ON position within 3 minutes after the vehicle was turned off, the indicator does not illuminate.

! WARNING

Never allow an adult passenger to ride in the front passenger seat when the passenger airbag OFF indicator is illuminated. During a collision, the airbag does not inflate if the indicator is illuminated. Turn on the passenger's front airbag or have your passenger move to the rear seat.

Side airbags

Front seat



Front center side airbag (Driver seat)

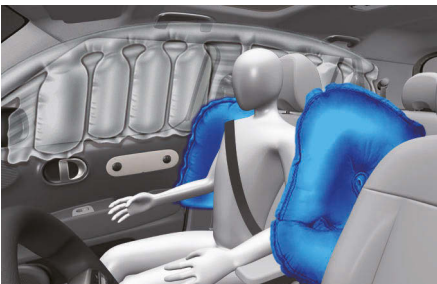

Side airbags are located in each front seat.

The side airbags are designed to deploy during certain side impact collisions, depending on the crash severity.

For the vehicle equipped with a rollover sensor, side and/or curtain airbags and pretensioners on both sides of the vehicle are designed to deploy if a rollover or possible rollover is detected.

The side airbags are not designed to deploy in all side impact or rollover situations.

WARNING

To reduce the risk of serious injury or death from an inflating side airbag:

- Seat belts must be worn at all times to help keep occupants positioned properly.
- Do not allow passengers to lean their heads or bodies onto doors, put their arms on the doors, stretch their arms out of the window, or place objects between the doors and seats.
- Do not use any accessory seat covers. It may reduce or prevent the effectiveness of the system.
- Do not hang other objects except clothes. In an accident it may cause vehicle damage or personal injury especially when air bag is inflated.
- Do not place any objects over the airbag location or between the airbag and yourself. Also, do not attach any objects around the area the airbag inflates such as door, side door glass, and front and rear pillar.
- Do not place any objects between the door and the seat. They may become dangerous projectiles if the side airbag inflates.
- Do not install any accessories on the side or near the side airbags.
- Do not cause an impact to the doors when the Start/Stop button is in the ON or START position because the side airbags can inflate.
- If the seat or seat cover is damaged, we recommend that your vehicle be inspected by an authorized HYUNDAI dealer.

Curtain airbags

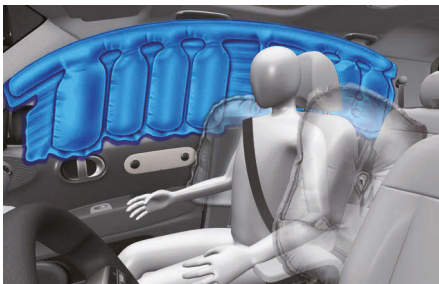

Curtain airbags are located along both sides of the roof rails above the front and rear doors.

They are designed to help protect the heads of the front seat occupants and the rear outboard seat occupants in certain side impact collisions.

The curtain airbags are designed to deploy during certain side impact collisions, depending on the crash severity.

For the vehicle equipped with a rollover sensor, the side and/or curtain airbags and pretensioners on both sides of the vehicle may deploy if a rollover or possible rollover is detected.

The curtain airbags are not designed to deploy in all side impact or rollover situations.

WARNING

To reduce the risk of serious injury or death from an inflating curtain airbag:

- Seat belts must be worn at all times to help keep occupants positioned properly.
- Properly secure a Child Restraint System as far away from the door as possible.
- Do not place any objects over the air bag. Also, do not attach any objects around the area the air bag inflates such as door, side door glass, front and rear pillar, and roof side rail.
- Do not hang other objects except clothes, especially hard or breakable objects near air bag locations. In an accident, it may cause vehicle damage or personal injury.
- Do not allow passengers to lean their heads or bodies onto doors, put their arms on the doors, stretch their arms out of the window, or place objects between the doors and seats.
- Do not open or repair the side curtain airbags yourself. If necessary, we recommend that the airbag be inspected by an authorized HYUNDAI dealer.

How does the airbags system operate?

The SRSCM (Supplemental Restraint System Control Module) continually monitors all SRS components while the Start/Stop button is ON to determine if a crash impact is severe enough to require airbag deployment or pretensioner seat belt deployment.

During a moderate to severe frontal collision, sensors detect the vehicle's rapid deceleration. If the rate of deceleration is high enough, the SRSCM inflates the front airbags with the force needed.

The front airbags help protect the driver and front passenger by responding to frontal impacts in which seat belts alone cannot provide adequate restraint. When needed, the side airbags help provide protection in the event of a side impact or rollover by supporting the side upper body area.

- Airbags are activated (able to inflate if necessary) only when the Start/Stop button is in the ON or START position, and it may be activated within 3 minutes after the vehicle is turned off.
- Airbags inflate in the event of certain frontal or side collisions to help protect the occupants from serious physical injury.
- There is no single speed at which the airbags will inflate. Generally, airbags are designed to inflate based upon the severity of a collision and its direction. Airbag deployment also depends on a number of other factors including vehicle speed, angles of impact and the density and stiffness of the vehicles or objects which your vehicle impacts during a collision. The determining factors are not limited to those mentioned above.
- The front airbags completely inflate and deflate in an instant. It is virtually impossible for you to see the airbags inflate during an accident. It is much more likely that you simply see the deflated airbags hanging out of their storage compartments after the collision.
- In addition to inflating in serious side collisions, vehicles equipped with a rollover sensor, side and/or curtain airbags inflate if the sensing system detects a rollover.

When a rollover is detected, curtain airbags remain inflated longer to help provide protection from ejection, especially when used in conjunction with the seat belts.

- To help provide protection, the airbags must inflate rapidly. The speed of airbag inflation is a consequence of extremely short time in which the airbag inflates between the occupant and the vehicle structures before the occupant impacts those structures. This speed of inflation reduces the risk of serious or life-threatening injuries and is thus a necessary part of airbag design.

However, the rapid airbag inflation may also cause injuries that include facial abrasions, bruises, and broken bones because the inflation speed also causes the airbags to expand with great force.

- There are even circumstances under which contact with the airbag may cause fatal injuries, especially when the occupant is positioned excessively close to the airbag.

WARNING

To reduce the risk of serious injury or death from an inflating airbag:

- Never place a child restraint in the front passenger seat. Always properly restrain children under age 13 in the rear seats of the vehicle.
 - Adjust the front passenger's and driver's seats as far to the rear as possible while allowing you to maintain full control of the vehicle.
 - Hold the steering wheel with hands at the 9 o'clock and 3 o'clock positions.
 - Never place anything or anyone between the airbag and the seat occupant.
 - Do not allow the front passenger to place their feet or legs on the dashboard.
-

Driver's front airbag (1)



When the SRSCM detects a sufficiently severe impact to the front of the vehicle, it automatically deploys the front airbags.

Driver's front airbag (2)



Upon deployment, tear seam in the pad cover separates from the expansion of the airbags.

A fully inflated airbag, in combination with a properly worn seat belt, slows the driver's or the front passenger's forward motion, reducing the risk of head and chest injury.

Driver's front airbag (3)



Passenger's front airbag (4)



After complete inflation, the airbag immediately starts deflating, enabling the driver to maintain forward visibility and steer or operate other controls.

WARNING

To prevent objects from becoming dangerous projectiles when the passenger's airbag inflates:

- Do not install or place any objects (drink holder, CD holder, stickers, etc.) on the front passenger's panel above the glove box where the passenger's airbag is located.
- Do not install a container of liquid air freshener near the instrument cluster or on the instrument panel surface.

What to expect after an airbag inflates

After a frontal or side airbag inflates, it deflates very quickly. Airbag inflation does not prevent the driver from seeing out of the windshield or being able to steer. Curtain airbags may remain partially inflated for some time after they deploy.

WARNING

After an airbag inflates, take the following precautions:

- Open your windows and doors as soon as possible after impact to reduce prolonged exposure to the powder released by the inflating airbag.
 - Do not touch the airbag storage area's internal components immediately after an airbag has inflated. The parts that come into contact with an inflating airbag may be very hot.
 - Always wash exposed skin areas thoroughly with cold water and mild soap.
 - We recommend to have an authorized HYUNDAI dealer inspect your vehicle and replace components as required before operating your vehicle again. Airbags are designed to be used only.
-

Noise and smoke from inflating airbag

When the airbags inflate, they make a loud noise and may release powder inside the vehicle. After the airbag inflates, you may feel discomfort while breathing. This may be due to the impact of the airbag or the seat belt with your chest and it may also be due to breathing residual powder in the air and around your vehicle. The powder may aggravate asthma for some people. If you experience breathing problems after an airbag deployment, seek medical attention immediately.

Though the powder is nontoxic, it may cause irritation to the skin, eyes, nose, throat, etc. If this is the case, wash and rinse with cold water immediately and seek medical attention if the symptoms persist.

Do not install a Child Restraint System on the front passenger's seat

Type A



Type B

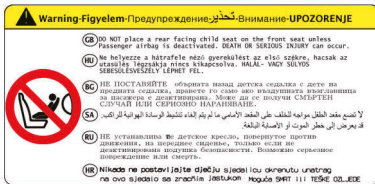

Never install a Child Restraint System in the front passenger seat, unless the airbag is deactivated.

WARNING

NEVER use a rearward facing Child Restraint on a seat protected by an ACTIVE AIRBAG in front of it, DEATH or SERIOUS INJURY to the CHILD can occur.

SRS warning light



The SRS (Supplemental Restraint System) airbag warning light on the instrument panel displays the airbag symbol in the illustration. The light indicates if there is a potential problem with your airbag system, which could include your side and/or curtain airbags used for rollover protection.

WARNING

If your SRS malfunctions, the airbags may not inflate properly during a collision increasing the risk of serious injury or death.

Your SRS malfunctions in the following conditions:

- The light does not turn on for about 3-6 seconds when the Start/Stop button is in the ON position.
- The light stays on after illuminating for about 3-6 seconds.
- The light comes on while the vehicle is moving.
- The light blinks when the vehicle is running.

We recommend that an authorized HYUNDAI dealer inspect the SRS as soon as possible.

Why didn't my airbag go off in a collision?

There are certain types of accidents in which the airbag would not deploy including rear impacts and second or third collisions in multiple impact accidents, as well as low speed impacts. Damage to the vehicle indicates a collision energy absorption, and is not an indicator of whether or not an airbag should have inflated.

Airbag collision sensors

WARNING

To reduce the risk of an airbag deploying unexpectedly and causing serious injury or death:

- Do not hit or allow any objects to impact the locations where airbags or sensors are installed.
- Do not perform maintenance on or around the airbag sensors. If the location or angle of the sensors is changed, the air bags may deploy when they should not or may not deploy.
- Do not install bumper guards with non genuine HYUNDAI or non-equivalent parts. It may adversely affect the collision and airbag deployment performance.
- Move the Start/Stop button to the OFF or ACC position and wait for 3 minutes before the vehicle is towed to prevent unintended air bag deployment.
- We recommend that all air bag repairs are conducted by an authorized HYUNDAI dealer.

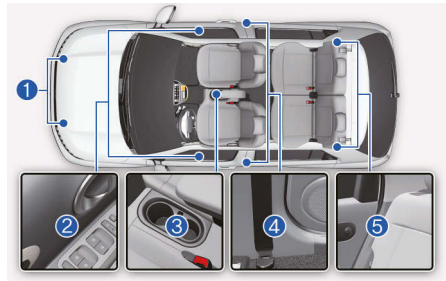

- (1) Front impact sensor
- (2) Side impact sensor (Pressure)
- (3) SRS control module/Rollover sensor
- (4) Side impact sensor (Acceleration)
- (5) Side impact sensor (Acceleration)

Airbag inflation conditions

Front airbags



Front airbags are designed to inflate in a frontal collision depending on the severity of impact.

Side and curtain airbags

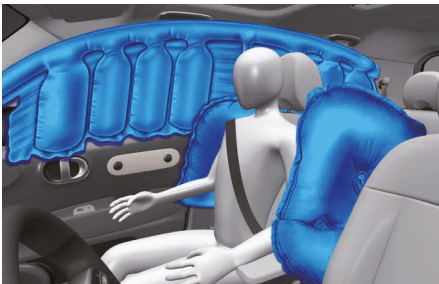

Side and curtain airbags are designed to inflate when an impact is detected by side collision sensors depending on the severity of impact resulting from a side impact collision.

Although the driver's and front passenger's airbags are designed to inflate in frontal collisions and side and curtain airbags are designed to inflate in side impact collisions, airbags may inflate in other types of collisions if the sensors detect a sufficient impact.

Also, the side and curtain airbags inflate when a rollover is detected by a rollover sensor.

If the vehicle chassis is impacted by bumps or objects on unimproved roads, the airbags may deploy. Drive carefully on unimproved roads or on surfaces not designed for vehicle traffic to prevent unintended airbag deployment.

Airbag non-inflation conditions



In certain low-speed collisions, the airbags may not deploy. The airbags are designed not to deploy in such cases because they may not provide benefits beyond the protection of the seat belts.

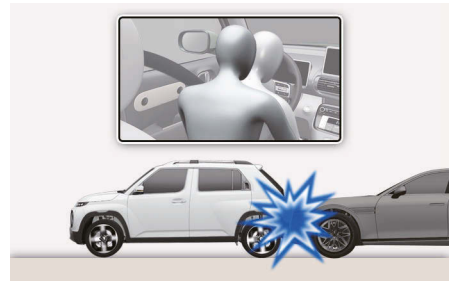

Front airbags are not designed to inflate in rear collisions, because occupants are moved backward by the force of the impact.

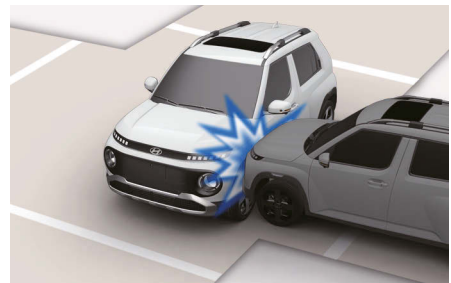

Front airbags may not inflate in side impact collisions, because occupants move in the direction of the collision.

Side and curtain airbags may inflate depending on the severity of impact.

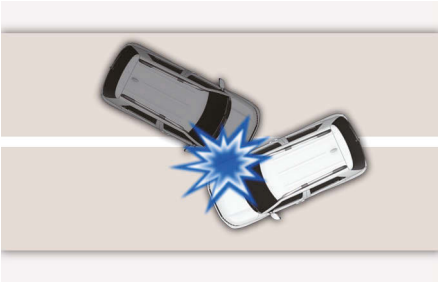

In an angled collision, the force of impact may direct the occupants in a direction where the airbags would not be able to provide any additional benefit, and thus the sensors may not deploy any airbags.



Just before impact, drivers often brake heavily. Such heavy braking lowers the front portion of the vehicle causing it to "nosedive". This is particularly important when the vehicle in front has a higher ground clearance. Airbags may not inflate if your vehicle is in a "nosedive" condition because the collision forces detected by the sensors may have been significantly reduced.



Front airbags may not inflate in rollover accidents because front airbag deployment would not provide additional occupant protection.

i Information

The side and curtain airbags may inflate in a rollover situation, when detected by the rollover sensor.



Airbags may not inflate if the vehicle collides with objects such as utility poles or trees, where the point of impact is concentrated and the collision energy is absorbed by the vehicle structure.

SRS care

The SRS is virtually maintenance-free and there are no parts you can safely service by yourself. If the SRS airbag warning light does not illuminate when the Start/Stop button is in the ON position or continuously remains on, we recommend that the system be immediately inspected by an authorized HYUNDAI dealer.

We recommend any work on the SRS system, such as removing, installing, repairing, or any work on the steering wheel, the front passenger's panel, front seats, and roof rails should be performed by an authorized HYUNDAI dealer. Improper handling of the SRS system may result in serious personal injury or death.

WARNING

To reduce the risk of serious injury or death:

- Do not attempt to modify or disconnect the SRS components or wiring, including the addition of any kind of badges to the pad covers or modifications to the body structure.
- Do not place objects over or near the airbag modules on the steering wheel, instrument panel, and the front passenger's panel above the glove box.
- Clean the airbag pad covers with a soft cloth moistened with water. Solvents or cleaners may adversely affect the airbag covers and proper deployment of the system.
- We recommend that inflated airbags be replaced by an authorized HYUNDAI dealer.
- If components of the airbag system must be discarded, or if the vehicle must be scrapped, observe safety precautions. We recommend that you consult an authorized HYUNDAI dealer for the necessary information.

Additional safety precautions

Passengers should not move out of or change seats while the vehicle is moving. A passenger who is not wearing a seat belt during a collision or emergency stop can be thrown against the inside of the vehicle, against other occupants, or be ejected from the vehicle.

Do not use any accessories on seat belts.

Devices claiming to improve occupant comfort or reposition the seat belt can reduce the protection provided by the seat belt and increase the chance of serious injury in a collision.

Do not modify the front seats.

Modification of the front seats may interfere with the operation of the Supplemental Restraint System sensing components or side airbags.

Do not place items under the front seats.

Placing items under the front seats may interfere with the operation of the Supplemental Restraint System sensing components and wiring harnesses.

Do not cause impact to the doors.

Impact to the doors when the Start/Stop button is in the ON or START position may cause the airbags to inflate.

Adding equipment to or modifying your airbag equipped vehicle

If you modify your vehicle by changing your vehicle's frame, bumper system, front end or side sheet metal, or ride height, this may affect the operation of your vehicle's Supplemental Restraint System.

Airbag warning labels



Airbag warning labels are attached to alert the driver and passengers of potential risks of the airbag system. Be sure to read all of the information about the airbags that are installed on your vehicle in this Owners Manual.

4. Instrument Cluster

Instrument cluster	4-2
Instrument cluster control.....	4-3
Gauges and meters.....	4-3
Reduction gear shift indicator	4-5
Warning and indicator lights.....	4-6
Cluster display messages.....	4-16
Cluster display (Type A)	4-20
Cluster display control.....	4-20
Cluster display modes	4-21
User settings mode.....	4-23
Trip computer.....	4-29
Cluster display (Type B)	4-31
Cluster display control.....	4-31
View modes.....	4-31
Vehicle settings (infotainment system)	4-34
Setting your vehicle.....	4-34

Instrument cluster

Type A

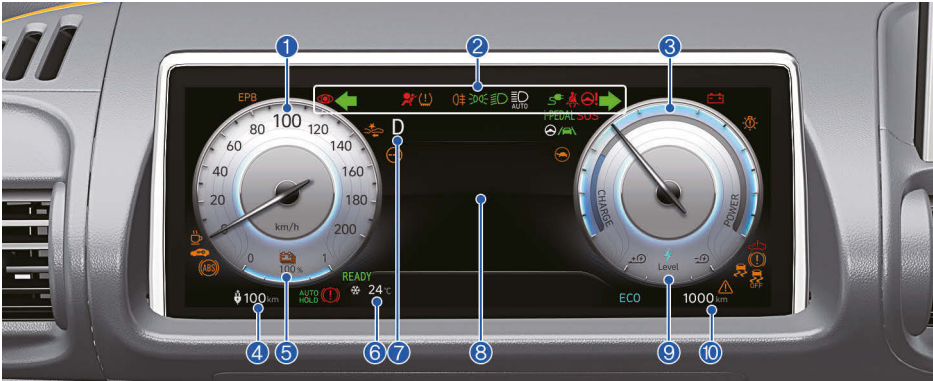

Type B

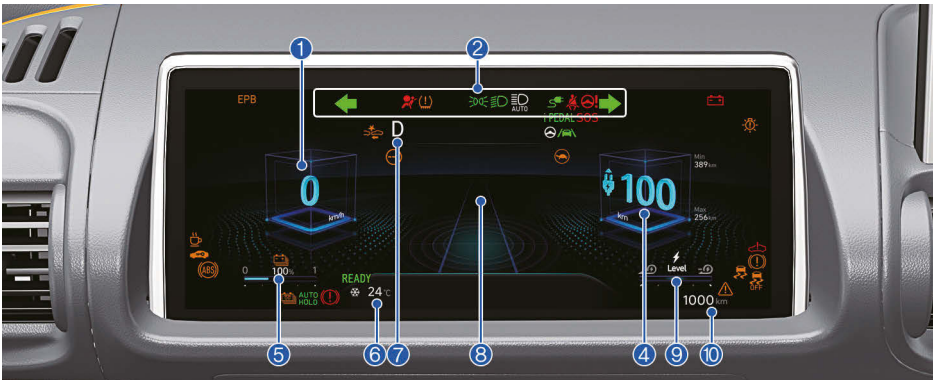

The actual cluster in the vehicle may differ from the illustration. For more information, refer to the "Gauges and meters" section in this chapter.

- (1) Speedometer
- (2) Warning and indicator lights
- (3) Power/Charge gauge
- (4) Distance to empty
- (5) Battery SOC (State of Charge) gauge
- (6) Outside temperature gauge
- (7) Reduction gear shift indicator
- (8) Cluster display
- (9) Regenerative braking level indicator
- (10) Odometer

Instrument cluster control

Instrument cluster theme selection

You can adjust the theme of the instrument cluster in the instrument cluster or infotainment system. Select **Cluster > Theme Selection**

Instrument panel illumination

You can adjust the brightness of the instrument cluster, Select **Light > Illumination** in the instrument cluster or **Light > Brightness** in the infotainment system.

i Information

The infotainment system may change after software updates. For more information, refer to the manual provided in the infotainment system and the quick reference guide.

! WARNING

Never adjust the instrument cluster while driving. This could result in loss of control and lead to an accident that may cause death, serious injury, or vehicle damage.

Gauges and meters

Speedometer

Type A, B

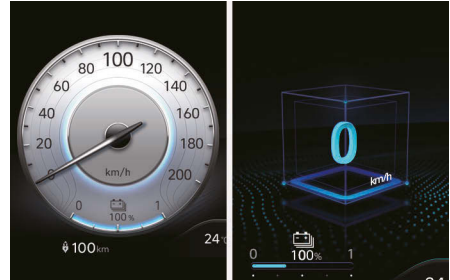

The speedometer indicates the speed of the vehicle and is calibrated in kilometers per hour (km/h) and/or miles per hour (MPH).

Power/charge gauge

Type A

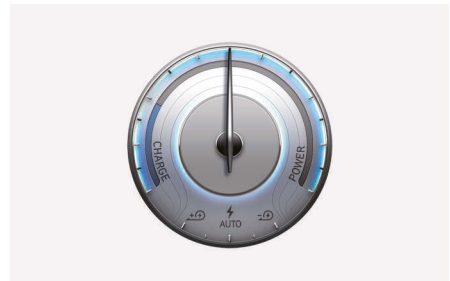

The Power/Charge Gauge shows the energy consumption rate of the vehicle and the charge/discharge status of the regenerative brakes.

- **CHARGE:** It shows the charging status of the battery, which is charged by the generative brakes, when depressing the brake pedal or decreasing the vehicle speed due to coasting. The more electric energy is charged, the more the gauge level turns counterclockwise.

- **POWER:** It shows the discharging status of the motor when the vehicle is accelerating. The more electric energy is discharged (used), the more the gauge level turns clockwise.

State of charge (SOC) gauge for high voltage battery

Type A,B

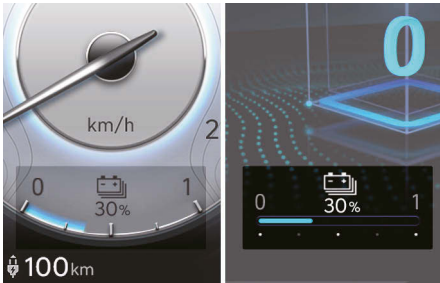

- The SOC gauge shows the charging status of the high voltage battery.
- The low percentage number on the indicator indicates that there is not enough energy in the high voltage battery. 100 % indicates that the driving battery is fully charged.
- When the high voltage battery level is lower than the certain point, its warning light (🔋) illuminates. When the warning light illuminates, charge your vehicle.
- When driving on highways or motorways, make sure to check in advance if the driving battery is charged enough.

i Information

Battery capacity warning level

- Long Range: 20 %
- Standard: 25 %
- Cross: 20 %

NOTICE

When the high voltage battery level is low, the Power Down indicator light illuminates and the vehicle power is limited.

Charge the battery immediately since your vehicle may not be driven, or may roll back on a slope with the indicator light illuminated.

Outside temperature gauge

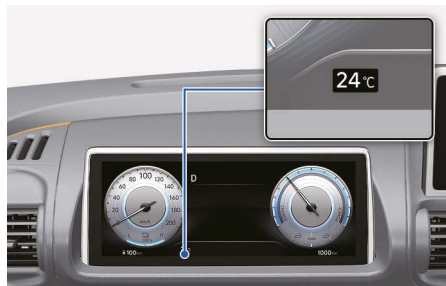

The outside ambient temperature appears in the lower portion of the cluster display. The temperature reads in Celsius or Fahrenheit depending on the units selected from in the instrument cluster or infotainment system.

Select **Units > Temperature Unit**.

Both the temperature unit on the cluster display and climate control screen will change.

i Information

The infotainment system may change after software updates. For more information, refer to the manual provided in the infotainment system and the quick reference guide.

Odometer



The odometer indicates the total distance that the vehicle has been driven and is used to determine when periodic maintenance is required.

Distance to empty

Type A, B

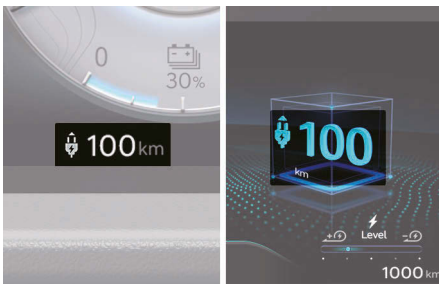

The distance to empty is the estimated distance the vehicle can be driven with the remaining electric energy.

For more information, refer to the "Factors affecting the distance to empty" section in chapter 1.

i Information

- The distance to empty may differ from the actual driving distance as it is an estimate of the available driving distance.
- The distance to empty may differ significantly based on driving conditions, driving habits, and condition of the vehicle.

- If the vehicle is not on level ground or the battery power has been interrupted, the distance to empty function may not operate correctly.

Reduction gear shift indicator

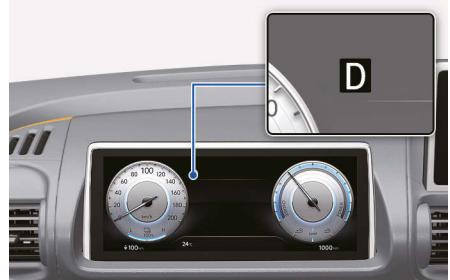

The reduction gear shift indicator in the upper corner of the cluster display indicates the current gear or P (Park).

Regenerative braking level indicator



The regenerative brake indicates the level of the regenerative braking that you set. And it also indicates Smart regenerative system's operation status.

For more information, refer to the "Regenerative braking system" section in chapter 6.

Warning and indicator lights

i Information

Make sure that all warning lights are OFF after starting the vehicle. If any light is still ON, this indicates a situation that needs attention.

Ready indicator

READY

This indicator illuminates:

When the vehicle is ready to be driven.

- ON: Normal driving is possible.
- OFF: Normal driving is not possible, or a problem has occurred.
- Blinking: Emergency driving.

When the ready indicator goes OFF or blinks, there is a problem with the system. If this occurs, we recommend that your vehicle be inspected by an authorized HYUNDAI dealer.

Service warning light



This warning light illuminates:

- When the Start/Stop button is in the ON position. It illuminates for about 3 seconds and then goes off.
- When there is a problem with related parts of the electric vehicle control system, such as sensors, etc.

When the warning light illuminates while driving, or does not go OFF after starting the vehicle, we recommend that your vehicle be inspected by an authorized HYUNDAI dealer.

Power down indicator light



This indicator light illuminates:

When the power is limited for the safety of the high-powered parts of an electric vehicle. The power is limited for the following reasons.

- The high voltage battery level is too low or voltage is decreasing.
- The temperature of the high voltage battery is too high or too low.
- The temperature of the motor is high.

NOTICE

- Do not accelerate or start the vehicle suddenly when the Power Down indicator light is ON.
- Your vehicle may not be driven, or may roll back on a slope with the indicator light ON due to the limitation of vehicle power.

i Information

Unless both the Service warning light and Power down indicator light illuminate at the same time, it is not a failure.

Charging connector indicator light



This warning light illuminates:

This warning light indicates the connection status of the charging connector. When the charging connector is connected to the vehicle, the green light illuminates for charging.

High voltage battery level warning light



This warning light illuminates:

When the high voltage battery level is low.

Charge the high voltage battery immediately.

Seat belt warning light



This warning light informs the driver that the seat belt is not fastened.

For more information, refer to the "Seat belts" section in chapter 3.

Airbag warning light



This warning light illuminates:

- When the Start/Stop button is in the ON position. It illuminates for 3-6 seconds and then goes off.
- When there is a malfunction with the Safety Restraint System (SRS).

If the Airbag warning light remains illuminated while driving, we recommend that your vehicle be inspected by an authorized HYUNDAI dealer.

Regenerative brake warning light



This warning light illuminates:

When the regenerative brake does not operate and the brake does not perform well. This causes the Parking Brake warning light (red) and Regenerative Brake warning light (yellow) to illuminate simultaneously.

If this occurs, drive safely and we recommend that you have your vehicle inspected by an authorized HYUNDAI dealer.

The operation of the brake pedal may be more difficult than normal and the braking distance may increase.

Parking brake and brake fluid warning light



This warning light illuminates:

- When the Start/Stop button is in the ON position. It illuminates for about 3 seconds and then goes off once the parking brake is released.
- Whenever the parking brake is applied.
- Whenever the brake fluid level in the reservoir is low.
 - If the warning light illuminates with the parking brake released, it indicates the brake fluid level in the reservoir is low.

If the brake fluid level in the reservoir is low:

1. Drive carefully to the nearest safe location and stop your vehicle.
2. With the vehicle stopped, check the brake fluid level immediately and add fluid as required (For more information, refer to the "Brake fluid" section in chapter 9). After adding brake fluid, check all brake components for fluid leaks. If a brake fluid leak is found, or if the warning light remains on, or if the brakes do not operate properly, do not drive the vehicle. We recommend that your vehicle be inspected by an authorized HYUNDAI dealer.

Dual-diagonal braking system

Your vehicle is equipped with the dual-diagonal braking system. This means you still have braking on two wheels even if one of the dual systems should fails.

With only one of the dual systems working, more than normal pedal travel and greater pedal force are required to stop the vehicle.

Also, the vehicle does not stop in a short distance if only a portion of the braking system is working.

WARNING

If the parking brake warning light illuminates with the parking brake released, it indicates that the brake fluid level is low. We recommend that your vehicle be inspected by an authorized HYUNDAI dealer.

Anti-lock Brake System (ABS) warning light



This warning light illuminates:

- When the Start/Stop button is in the ON position. It illuminates for about 3 seconds and then goes off.
- Whenever there is a malfunction with the ABS.

The hydraulic braking system still operates even if there is a malfunction with the ABS. If the ABS warning light remains illuminated while driving, we recommend that your vehicle be inspected by an authorized HYUNDAI dealer.

Electronic Brake Force Distribution (EBD) System warning light



These two warning lights illuminate at the same time while driving:

When the ABS and brake system does not work normally.

If both the ABS warning light and the Parking Brake warning light remain illuminated while driving, we recommend that your vehicle be inspected by an authorized HYUNDAI dealer.

WARNING

When both ABS and Parking Brake warning lights are on, the braking system does not work normally and you may experience an unexpected and dangerous situation during sudden braking.

Avoid high speed driving and abrupt braking.

We recommend that your vehicle be inspected by an authorized HYUNDAI dealer as soon as possible.

i Information

When the ABS warning light is on or both ABS and Parking Brake warning lights are on, the speedometer, odometer, or tripmeter may not work. Also, the MDPS warning light may illuminate and the steering effort may increase or decrease.

Motor Driven Power Steering (MDPS) warning light



This warning light illuminates:

- When the Start/Stop button is in the ON position. It illuminates for about 3 seconds and then goes off.
- Whenever there is a malfunction with the Motor Driven Power Steering.

If the MDPS warning light remains illuminated while driving, we recommend that your vehicle be inspected by an authorized HYUNDAI dealer.

Master warning light



This warning light illuminates:

When there is a malfunction in operation in any of the following systems:

- Forward Collision-Avoidance Assist malfunction
- Forward Collision-Avoidance Assist radar blocked
- Blind-Spot Collision-Avoidance Assist malfunction (if equipped)
- Blind-Spot Collision-Avoidance Assist radar blocked (if equipped)
- Rear Cross-Traffic Collision-Avoidance Assist malfunction (if equipped)
- Rear Cross-Traffic Collision-Avoidance Assist radar blocked (if equipped)
- Exterior light malfunction
- LED headlight malfunction (if equipped)
- High Beam Assist malfunction (if equipped)
- Smart Cruise Control malfunction (if equipped)
- Smart Cruise Control radar blocked (if equipped)
- Lane Following Assist malfunction (if equipped)
- Low washer fluid (if equipped)
- Tire Pressure Monitoring System (TPMS) malfunction

If the issue is resolved, the Master Warning Light turns off.

Electronic Parking Brake (EPB) warning light

EPB

This warning light illuminates:

- When the Start/Stop button is in the ON position. It illuminates for about 3 seconds and then goes off.
- Whenever there is a malfunction with EPB.

If the EPB warning light remains illuminated while driving, we recommend that your vehicle be inspected by an authorized HYUNDAI dealer.

i Information

The Electronic Parking Brake (EPB) warning light may illuminate when the Electronic Stability Control (ESC) indicator light comes on to indicate that ESC is not working properly. This does not indicate malfunction of EPB.

12 V Battery charging system warning light



This warning light illuminates:

When there is a malfunction with electrical charging system.

If there is a malfunction with electrical charging system:

1. Drive carefully to the nearest safe location and stop your vehicle.
2. Turn the vehicle off and check the electrical charging system.

If the Charging system warning light remains illuminated while driving, we recommend that your vehicle be inspected by an authorized HYUNDAI dealer.

Low tire pressure warning light



This warning light illuminates:

- When the Start/Stop button is in the ON position. It illuminates for about 3 seconds and then goes off.
- When one or more tires are significantly under-inflated. (The location of the under-inflated tire appears on the cluster display.)

This warning light remains on after blinking for about 70 seconds or repeatedly blinks on and off at about 4 second intervals:

- When there is a malfunction with the TPMS.

In this case, we recommend that you have the vehicle inspected by an authorized HYUNDAI dealer as soon as possible.

WARNING

Safe Stopping

- The TPMS cannot alert you to severe and sudden tire damage caused by external factors.
- If you notice any vehicle instability, immediately take your foot off the accelerator pedal, apply the brakes gradually with light force, and slowly move to a safe position off the road.

For more information, refer to the "Tire pressure monitoring system (TPMS)" section in chapter 8.

Forward Safety warning light



This warning light illuminates:

- When the Start/Stop button is in the ON position. It illuminates for about 3 seconds and then goes off.
- Yellow: When Forward Safety of Forward Collision-Avoidance Assist is deselected, disabled, or a malfunction is detected.

If the yellow warning light remains on after the sensor has been uncovered or unblocked when the Forward Safety is set, we recommend that your vehicle be inspected by an authorized HYUNDAI dealer.

This warning light blinks:

- Red: When Forward Safety function is operating.

For more information, refer to the "Forward Collision-Avoidance Assist (FCA) (Front view camera only)" or "Forward Collision-Avoidance Assist (FCA) (Sensor fusion)" section in chapter 7.

Inattentive Driving Warning light

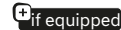
 if equipped



This warning light illuminates:

- When the Start/Stop button is in the ON position. It illuminates for about 3 seconds and then goes off.
- Yellow: When Driver Attention Warning is disabled or a malfunction is detected.

If the yellow warning light remains on after the front view camera has been uncovered or unblocked, we recommend that your vehicle be inspected by an authorized HYUNDAI dealer.

This warning light blinks:

- Yellow: Driver Attention Warning recommends to take a break.

For more information, refer to the "Driver Attention Warning (DAW)" section in chapter 7.

Forward Attention Warning light

 if equipped



This warning light illuminates:

- When the Start/Stop button is in the ON position. It illuminates for about 3 seconds and then goes off.
- Red: When Forward Attention Warning is disabled or a malfunction is detected. If the red warning light remains on after the in-cabin camera has been uncovered or unblocked, we recommend that your vehicle be inspected by an authorized HYUNDAI dealer.

This warning light blinks:

- Red: When Forward Attention Warning warns the driver to keep eyes on the road.

For more information, refer to the "Forward Attention Warning (FAW)" section in chapter 7.

Intelligent Speed Limit Assist indicator light

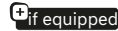
 if equipped



This indicator light illuminates:

- When the Start/Stop button is in the ON position. It illuminates for about 3 seconds and then goes off.
- Yellow: When Intelligent Speed Limit Assist is disabled, the front view camera is blocked, or a malfunction is detected.

If the yellow indicator light remains on after the front view camera has been uncovered or unblocked, we recommend that your vehicle be inspected by an authorized HYUNDAI dealer.

For more information, refer to the "Intelligent Speed Limit Assist (ISLA)" section in chapter 7.

Lane Safety indicator light

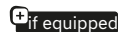
 if equipped



This indicator light illuminates:

- When the Start/Stop button is in the ON position. It illuminates for about 3 seconds and then goes off.
- Gray: When Lane Keeping Assist operating conditions are not satisfied.
- Green: When Lane Keeping Assist operating conditions are satisfied.

- Yellow: When Lane Safety is deselected, disabled, or a malfunction is detected.

If the yellow warning light remains on after the sensor has been uncovered or unblocked when Lane Safety is set, we recommend that your vehicle be inspected by an authorized HYUNDAI dealer.

This indicator light blinks:

- Green: When Lane Keeping Assist is operating.

For more information, refer to the "Lane Keeping Assist (LKA)" section in chapter 7.

Lane Following Assist indicator light



This indicator light illuminates:

- Green: When Lane Following Assist operating.
- Yellow: When Lane Following Assist operating conditions are not satisfied.

This indicator light blinks:

- White: When Lane Following Assist is cancelled.

For more information, refer to the "Lane Following Assist (LFA)" section in chapter 7.

LED headlight warning light

 if equipped



This warning light illuminates:

- When the Start/Stop button is in the ON position. It illuminates for about 3 seconds and then goes off.
- Whenever there is a malfunction with a LED headlight.

If the LED headlight warning light remains illuminated while driving, we recommend that your vehicle be inspected by an authorized HYUNDAI dealer.

This warning light blinks:

Whenever there is a malfunction with a LED headlight related part.

If this occurs, we recommend that your vehicle be inspected by an authorized HYUNDAI dealer as soon as possible.

NOTICE

Driving with the LED headlight warning light on or blinking may reduce LED headlight life.

Electronic Stability Control (ESC) indicator light



This indicator light illuminates:

- When the Start/Stop button is in the ON position. It illuminates for about 3 seconds and then goes off.
- Whenever there is a malfunction with ESC system.
If this occurs, we recommend that your vehicle be inspected by an authorized HYUNDAI dealer as soon as possible.

This indicator light blinks:

While ESC is operating.

For more information, refer to the "Electronic Stability Control (ESC)" section in chapter 6.

Electronic Stability Control (ESC) OFF indicator light



This indicator light illuminates:

- When the Start/Stop button is in the ON position. It illuminates for about 3 seconds and then goes off.
- When you deactivate ESC system by pressing the ESC OFF button.

For more information, refer to the "Electronic Stability Control (ESC)" section in chapter 6.

Immobilizer indicator light



This indicator light illuminates for up to 30 seconds:

When the vehicle detects the smart key in the vehicle with the Start/Stop button in the ACC or ON position.

- At this time, you can start the vehicle.
- The indicator light goes off after starting the vehicle.

This indicator light blinks for a few seconds:

When the smart key is not in the vehicle, you cannot start the vehicle.

This indicator light illuminates for a few seconds and goes off:

If the smart key is in the vehicle and the Start/Stop button is ON, but the vehicle cannot detect the smart key.

If this occurs, we recommend that your vehicle be inspected by an authorized HYUNDAI dealer.

This indicator light blinks:

Whenever there is a malfunction with the immobilizer system.

If this occurs, we recommend that your vehicle be inspected by an authorized HYUNDAI dealer.

Turn signal indicator light



This indicator light blinks:

When you operate the turn signal lever. If any of the following occur, there may be a malfunction with the turn signal system.

- The turn signal indicator light illuminates but does not blink.
- The turn signal indicator light blinks rapidly.
- The turn signal indicator light does not illuminate at all.

If any of these occur, we recommend that your vehicle be inspected by an authorized HYUNDAI dealer.

Rear fog indicator light

 if equipped



This indicator light illuminates:

When the rear fog lights are on.

Low beam indicator light

 if equipped



This indicator light illuminates:

When the headlights are on.

High beam indicator light



This indicator light illuminates:

- When the headlights are on and the turn signal lever is moved to the high beam position.
- When the turn signal lever is pulled into the Flash-to-Pass position.

Light ON indicator light



This indicator light illuminates:

When the position lights or headlights are on.

High Beam Assist indicator light



This indicator light illuminates:

When the high beam is on with the light switch in the AUTO position.

- White: When High Beam Assist is ready to operate.
- Green: When High Beam Assist is operating.

If your vehicle detects oncoming or preceding vehicles, High Beam Assist switches the high beam to low beam automatically.

For more information, refer to the "High Beam Assist (HBA)" section in chapter 5.

Battery conditioning mode indicator light



This indicator light illuminates:

On when battery conditioning mode is engaged.

AUTO HOLD indicator light



This indicator light illuminates:

- White: When you activate Auto Hold by pressing the AUTO HOLD button.
- Green: When you stop the vehicle completely by depressing the brake pedal with Auto Hold activated.
- Yellow: Whenever a malfunction with the Auto Hold is detected.

If the ^{AUTO}_{HOLD} indicator light remains yellow while driving, we recommend that your vehicle be inspected by an authorized HYUNDAI dealer.

For more information, refer to the "Electronic Parking Brake (EPB)" section in chapter 6.

Cluster display messages

Low EV charge

- Standard battery: The high voltage battery level reaches below 25 %.
- Long range battery: The high voltage battery level reaches below 20 %.
- Cross battery: The high voltage battery level reaches below 20 %.
- The (⚡) warning light on the instrument cluster turns on simultaneously.

Charge immediately. Power limited.

- Standard battery: The high voltage battery level reaches below 15 %.
- Long range battery: The high voltage battery level reaches below 10 %.
- Cross battery: The high voltage battery level reaches below 10 %.
- The (⚡) warning light on the instrument cluster turns on simultaneously.
- The vehicle's power may be reduced to minimize the energy consumption of the high voltage battery.

Shift to P

This message appears if the Start/Stop button is pressed to the OFF position without the gear in the P (Park) position.

If this occurs, the Start/Stop button goes to the ACC position.

Low key battery

When the Start/Stop button is pressed to the OFF position, a message may appear, indicating the internal battery of the smart key is low. Replace the smart key battery.

Press brake pedal to start vehicle

This message appears if the Start/Stop button is pressed repeatedly without depressing the brake pedal.

Start the vehicle by depressing the brake pedal and then pressing the Start/Stop button.

Key not in vehicle

This message appears if the smart key is not in the vehicle when you have left the vehicle with the Start/Stop button in the ON or Start position.

Always turn off the vehicle before leaving your vehicle.

Press START button again

If you cannot start the vehicle after the Start/Stop button is pressed, attempt to start the vehicle by pressing the Start/Stop button again.

If the warning message appears each time you press the Start/Stop button, we recommend that the vehicle be inspected by an authorized HYUNDAI dealer.

Check BRAKE SWITCH fuse

This message appears if the brake switch fuse is disconnected. Replace the fuse before starting the vehicle.

If that is not possible, start the vehicle by pressing the Start/Stop button for 10 seconds in the ACC position.

Shift to P to start vehicle

This message appears if you try to start the vehicle in any other position except P (Park).

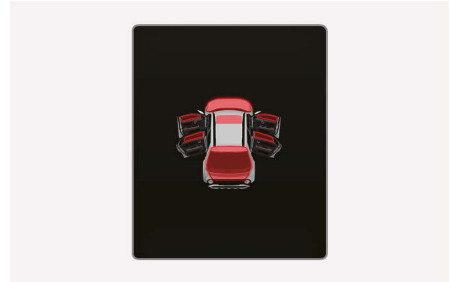
Door, Hood, Tailgate open indicator

This warning appears if any door or hood or tailgate is left open. The warning indicates which door is open on the cluster display.

⚠ CAUTION

Before driving the vehicle, confirm the door, hood, and tailgate are fully closed.

Sunroof open indicator

+ if equipped

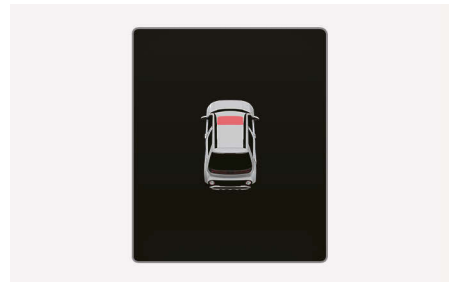

This warning appears if you turn off the vehicle when the sunroof is open.

Close the sunroof securely before leaving your vehicle.

Low tire pressure

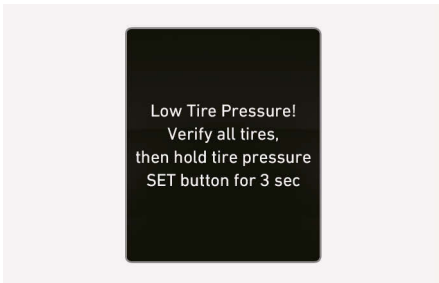

This warning message appears if the tire pressure is low.

For more information, refer to the "Tire pressure monitoring system (TPMS)" section in chapter 8.

Lights



This indicator displays which exterior light is selected using the lighting control.

You can activate or deactivate Wiper/Lights display function in the instrument cluster or infotainment system. Select **Cluster > Wiper/Lights Display** in the instrument cluster or **Cluster > Content selection > Wiper/lights display** in the infotainment system.

Wiper

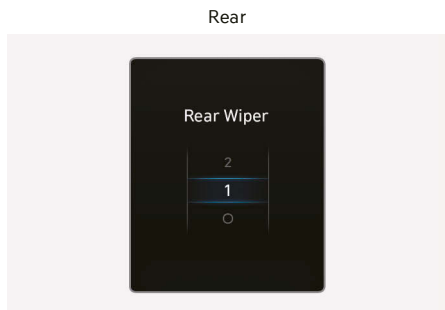
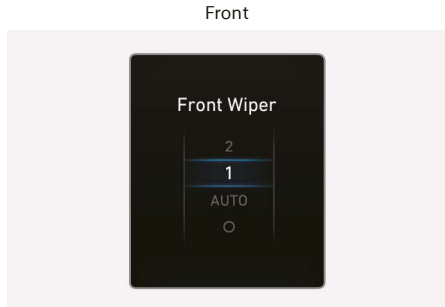

This indicator displays which wiper speed is selected using the wiper control.

You can activate or deactivate Wiper/Lights display function in the instrument cluster or infotainment system. Select **Cluster > Wiper/Lights Display** in the instrument cluster or **Cluster > Content selection > Wiper/lights display** in the infotainment system.

i Information

The infotainment system may change after software updates. For more information, refer to the manual provided in the infotainment system and the quick reference guide.

Low washer fluid

This message appears if the washer fluid level in the reservoir is nearly empty.

Have the washer fluid reservoir refilled.

Check turn signal

 if equipped

This message appears if the turn signal lights are not operating properly.

Replace the burned out bulb with a new one with the same wattage rating.

Check headlight LED

 if equipped

This message appears if there is a problem with the LED headlight. We recommend that your vehicle be inspected by an authorized HYUNDAI dealer.

Check Active Air Flap system

This warning message appears in the following situations:

- There is a malfunction with the actuator flap.
- There is a malfunction with the actuator air flap controller.
- The air flap does not open.



When all of the above conditions are fixed, the warning disappears.

Cluster display (Type A)

Cluster display control



The cluster display modes can be changed by using the control switches.

Switch	Function
	MODE button for changing view modes
	MOVE switch for changing items
OK	SELECT/RESET button for setting or resetting the selected item

i Information

When the infotainment system is applied, only the User Settings mode on the infotainment system is supported but the User Settings mode on the instrument cluster is not supported.

Cluster display modes

Modes	Explanation
Trip Computer	This mode displays driving information such as the tripmeter, energy economy, etc. For more details, refer to "Trip computer" in this chapter.
Turn By Turn (TBT)	This mode displays the state of the navigation.
Driving Assist	<ul style="list-style-type: none"> • Lane Keeping Assist • Smart Cruise Control • Lane Following Assist
User Settings	In this mode, you can change settings of the doors, lamps, etc.
Warning	This mode displays warning messages related to the light malfunction, Tire pressure information, etc.

The information provided may differ depending on which functions are applicable to your vehicle.

Trip computer group

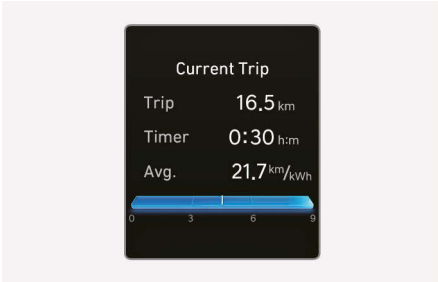

The trip computer group displays information related to vehicle driving parameters including energy economy, tripmeter information and vehicle speed. For more details, refer to "Trip computer" in this chapter.

Turn By Turn (TBT) group

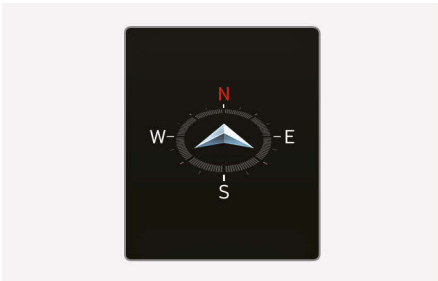

This group displays the state of the navigation.

Driving Assist group



LKA/SCC/LFA

Displays the state of Lane Keeping Assist, Smart Cruise Control and Lane Following Assist. For more information, refer to each system information in Chapter 7.

Master warning group



This warning light informs the driver the following situations.

- Forward Collision-Avoidance Assist malfunction (if equipped)
- Forward Collision-Avoidance Assist radar blocked (if equipped)
- Blind-Spot Collision-Avoidance Assist malfunction (if equipped)
- Blind-Spot Collision-Avoidance Assist radar blocked (if equipped)
- Lamp malfunction (if equipped)
- High Beam Assist malfunction (if equipped)
- Smart Cruise Control malfunction (if equipped)

The Master Warning Light illuminates if one or more of the above warning situations occur.

At this time, a Master Warning icon (⚠) will appear beside the User Settings icon (⚙), on the cluster display.

If the warning situation is solved, the master warning light will be turned off and the Master Warning icon will disappear.

Tire Pressure



This mode displays information related to Tire Pressure.

For more details, refer to "Tire pressure monitoring system (TPMS)" in chapter 8.

User settings mode

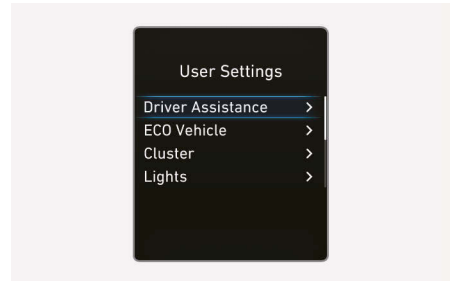

In this mode, you can change the settings of the instrument cluster, doors, lamps, etc.

1. Driver Assistance
2. ECO Vehicle
3. Cluster
4. Lights
5. Door
6. Digital keys
7. Convenience
8. Units
9. Language
10. Reset

The information provided may differ depending on which functions are applicable to your vehicle.

i Information

When the infotainment system is applied, only the User Settings mode on the infotainment system is supported but the User Settings mode on the instrument cluster is not supported.

1. Driver Assistance

Items	Explanation
Driving Convenience	<ul style="list-style-type: none"> Smart Cruise Control To set the Distance, Acceleration, Reaction Speed of Smart Cruise Control. For more details, refer to the "Smart Cruise Control (SCC)" in chapter 7.
Speed Limit	<ul style="list-style-type: none"> To adjust Speed Limit Assist Select country/Speed Limit Assist/Speed Limit Warning/Off For more details, refer to "Intelligent Speed Limit Assist (ISLA)" in chapter 7.
Warning Methods	<ul style="list-style-type: none"> To adjust the warning methods of the driver assistance system. Warning Volume: High/Medium/Low
Driver Attention Warning	<ul style="list-style-type: none"> Leading Vehicle Departure Alert To activate or deactivate the Leading vehicle departure alert. For more details, refer to the "Driver Attention Warning (DAW)" in chapter 7. Forward Attention Warning To activate or deactivate Forward Attention Warning. For more details, refer to the "Forward Attention Warning (FAW)" in chapter 7.
Driving Safety	<ul style="list-style-type: none"> Forward Safety To activate or deactivate the Forward Safety. Forward Safety Warning Timing To adjust the Forward Safety warning timing of the driver assistance system. For more details, refer to "Forward Collision-Avoidance Assist (FCA) (Front view camera only)" or "Forward Collision-Avoidance Assist (FCA) (Sensor fusion)" in chapter 7 Lane Safety To activate or deactivate the Lane Safety. For more details, refer to "Lane Keeping Assist (LKA)" in chapter 7. Blind-Spot Safety To activate or deactivate the Blind-Spot Safety. For more details, refer to "Blind-Spot Collision-Avoidance Assist (BCA)" in chapter 7. Exit Safety To activate or deactivate the Exit Safety. For more details, refer to "Safe Exit Warning (SEW)" in chapter 7.

Items	Explanation
Parking Safety	<ul style="list-style-type: none"> <li data-bbox="358 224 1064 329">• Parking Distance Warning Auto ON To activate or deactivate Parking Distance Warning Auto On. For more details, refer to "Reverse Parking Distance Warning (PDW)" in chapter 7. <li data-bbox="358 337 1064 443">• Rear Cross-Traffic Safety To activate or deactivate Rear Cross-Traffic Safety. For more details, refer to "Rear Cross-Traffic Collision-Avoidance Assist (RCCA)" in chapter 7.

i Information

The information provided may differ depending on which functions are applicable to your vehicle.

2. ECO vehicle

Items	Explanation
Utility Mode	<p>To activate or deactivate the Utility Mode.</p> <p>Utility Mode: This is a mode for using electricity from high voltage battery. (not possible to drive) It's useful while camping, etc.</p>
Smart Regeneration System	<p>To activate or deactivate the Smart Recuperation function.</p> <p>When activated, the recuperation level is adjusted automatically according to the current driving situation.</p> <p>For more details, refer to "Smart regeneration system" in chapter 6.</p>

3. Cluster

Items	Explanation
Theme Selection	You can select the theme of the cluster. Link to Drive Mode/ Classic A/ Classic B /Classic C /CUBE
Wiper/Lights Display	<ul style="list-style-type: none"> To activate or deactivate the Wiper/ Light mode. When activated, the cluster display shows the selected Wiper/Light mode whenever you changed the mode.
Traffic Signs	To set the traffic signs displayed.
Icy Road Warning	To activate or deactivate the icy road warning.
Cluster Voice Guidance Volume	To adjust the cluster voice guidance volume. <ul style="list-style-type: none"> Level 0-3
Welcome Sound	To activate or deactivate the welcome sound.

4. Lights

Items	Explanation
Illumination	To adjust the illumination level. <ul style="list-style-type: none"> Level 1-20
One Touch Turn Signal	<ul style="list-style-type: none"> Off: The one touch turn signal function will be deactivated. 3, 5, 7 Flashes: The turn signal indicator will blink 3, 5, or 7 times when the turn signal lever is moved slightly. For more details, refer to "Exterior lights" in chapter 5.
Headlight Delay	<ul style="list-style-type: none"> To activate or deactivate the headlamp delay function. For more details, refer to "Exterior lights" in chapter 5.
High Beam Assist	To activate or deactivate High Beam Assist. For more details, refer to "High Beam Assist (HBA)" in chapter 5.

5. Door

Items	Explanation
Automatically Lock (For europe)	Enable on Speed: All doors will be automatically locked when the vehicle speed exceeds 15 km/h (9 mph).
Automatically Lock (For general)	<ul style="list-style-type: none"> • Enable on Speed: All doors will be automatically locked when the vehicle speed exceeds 15 km/h (9 mph). • Enable on speed or shift: All doors will be automatically locked if the shift from the P (Park) position to the R (Reverse), N (Neutral), or D (Drive) position. (Only when the vehicle is running) • Off: The auto door lock operation will be deactivated.
Automatically Unlock	<ul style="list-style-type: none"> • On Shift to P: All doors will be automatically unlocked if the shift to P (Park) position. (Only when the vehicle is running) • Vehicle Off/On key out : All doors will be automatically unlocked when the ignition key is removed after the ignition switch is set to the LOCK/OFF position. • Off: The auto door unlock operation will be canceled.
2 Press unlock	<p>Off: The two press unlock function will be deactivated. Therefore, all doors will unlock if the door unlock button is pressed.</p> <p>On: Only the driver's door will unlock if the door unlock button is pressed. When the door unlock button is pressed again within 4 seconds, the remaining doors will unlock.</p>
Remote Window	To activate or deactivate the remote window control.

6. Digital Keys

To set the digital keys.

For more details, refer to "Hyundai Digital Key" in chapter 5.

7. Convenience

Items	Explanation
Rear Occupant Alert	<ul style="list-style-type: none"> To activate or deactivate the rear occupant alert system. For more details, refer to the "Rear Occupant Alert (ROA)" in chapter 5.
Service Interval	To activate or deactivate the service interval function.
Welcome Mirror/Light	<ul style="list-style-type: none"> On door unlock: The outside rearview mirrors are unfolded and the welcome light turns on automatically when the doors are unlocked. On driver approach: The outside rearview mirrors are unfolded and the welcome light turns on automatically when the vehicle is approached with the smart key. For more details, refer to "Exterior lights" in chapter 5.
Wireless Charging System for Mobile Devices	To activate or deactivate the wireless charging system in the front seat. For more details, refer to "Interior features" in chapter 5.
Auto Rear Wiper (in R)	To activate or deactivate the auto rear wiper.
Battery Conditioning	To activate or deactivate the battery conditioning.

8. Units

Items	Explanation
Speed Unit	To select the speed unit. (km/h, MPH)
Temperature Unit	To select the temperature unit. (°C, °F)
Energy Consumption Unit	To select the energy consumption unit. (km/kWh, kWh/100km)
Tire Pressure Unit	To select the tire pressure unit. (psi, kPa, bar)

9. Language

Items	Explanation
Language	Choose the language. You can choose the language in infotainment system. (if equipped)

10. Reset

Items	Explanation
Reset	You can reset the menus in the User Settings Mode. All menus in the User Settings Mode are reset to factory settings, except language and service interval.

Trip computer

The trip computer is a microcomputer-controlled driver information system that displays information related to driving.

i Information

Some driving information stored in the trip computer (for example Average Vehicle Speed) resets if the battery is disconnected.

Trip modes

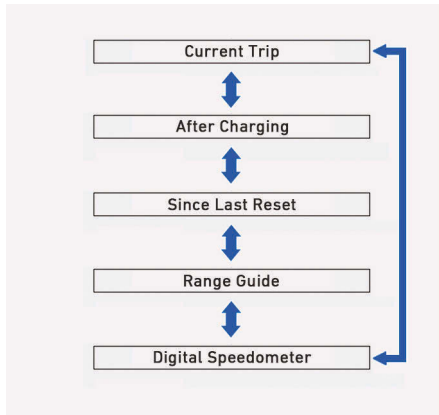

To change the trip mode, toggle the **^**, **v** switch on the steering wheel.

Current Trip

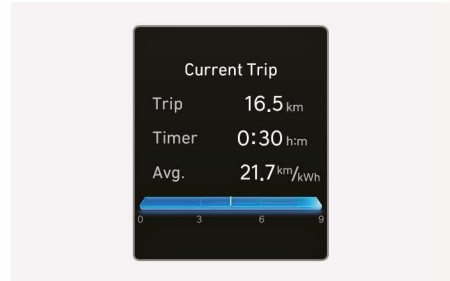

Trip distance, total driving time, average energy consumption, and instant energy consumption are displayed.

The information is combined for each ignition cycle. However, when the vehicle has been OFF for 3 minutes or longer the Drive Info screen is reset.

To reset manually, press the OK button on the steering wheel for more than 1 second when "Current Trip" appears.

After Charging

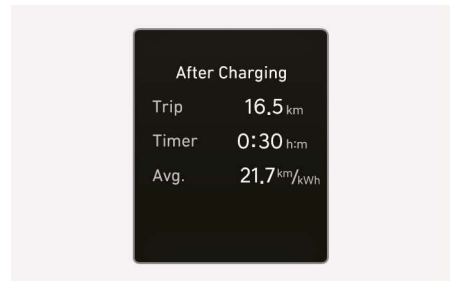

Trip distance, total driving time, average energy consumption, and instant energy consumption after the vehicle has been recharged are displayed. To reset manually, press the **OK** button on the steering wheel for more than 1 second when "After Charging" appears.

Since Last Reset

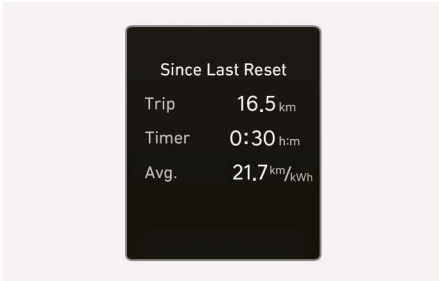

Accumulated trip distance, total driving time, and average energy economy are displayed.

The information is accumulated starting from the last reset.

To reset manually, press the **OK** button on the steering wheel for more than 1 second when "Since Last Reset" appears.

Range guide



This message shows the range guide.

Digital speedometer

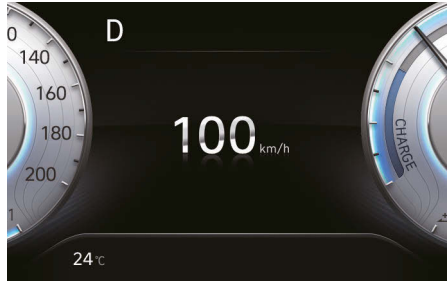



This message shows the speed of the vehicle (km/h, MPH).

Cluster display (Type B)

Cluster display control



Switch	Function
	MODE button for changing view modes
	MOVE switch for changing items
OK	SELECT/RESET button for setting or resetting the selected item

View modes

View modes	Explanation
Driving Assist	This mode displays Driver Assistance system such as Lane Keeping Assist, Smart Cruise Control, and Lane Following Assist etc.
Turn by Turn	This mode displays the navigation guidance.
Utility	This mode displays driving information such as the trip distance, electric energy economy, etc.

The information provided may differ depending on which functions are applicable to your vehicle.

Driving Assist view



LKA/SCC/LFA

Displays the state of Lane Keeping Assist, Smart Cruise Control, Lane Following Assist, and Highway Driving Assist. For more information, refer to each system information in Chapter 7.

Turn By Turn (TBT) view



Turn-by-turn navigation and distance/time to destination appear when Turn by Turn mode is selected.

Utility view

In the Utility view, using the **▲**, **▼** (UP, DOWN) switch, you may change through items in the following order.

Current Trip

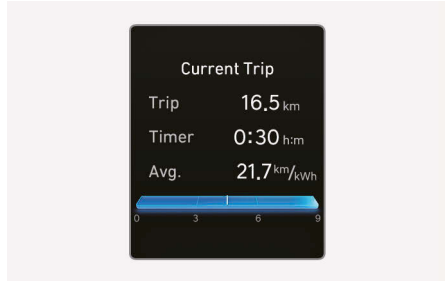

Trip distance, total driving time, average energy consumption, and instant energy consumption are displayed.

The information is combined for each ignition cycle. However, when the vehicle has been OFF for 3 minutes or longer the Drive Info screen is reset.

To reset manually, press the **OK** button on the steering wheel for more than 1 second when "Current Trip" appears.

After Charging

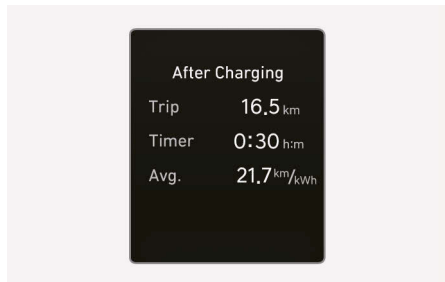

Trip distance, total driving time, average energy consumption, and instant energy consumption after the vehicle has been recharged are displayed. To reset manually, press the **OK** button on the steering wheel for more than 1 second when "After Charging" appears.

Since Last Reset

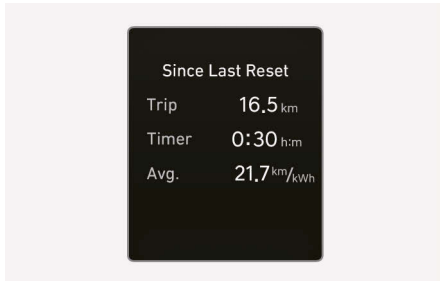

Accumulated trip distance, total driving time, and average energy economy are displayed.

The information is accumulated starting from the last reset.

To reset manually, press the **OK** button on the steering wheel for more than 1 second when "Since Last Reset" appears.

Tire pressure

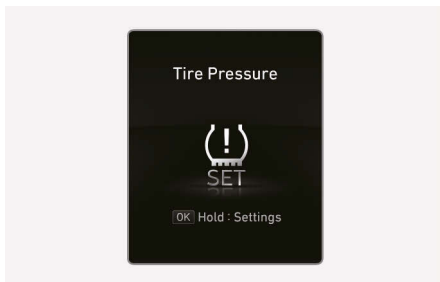

This mode displays information related to Tire Pressure.

For more information, refer to "Tire pressure monitoring system (TPMS)" section in chapter 8.

Additional information display

Driver assistance



The current operation condition of Manual Speed Limit Assist, Smart Cruise Control, Lane Following Assist, etc. appears.

Vehicle settings (infotainment system)

Vehicle Settings in the infotainment system provides user options for a the settings including door lock/unlock features, convenience features, driver assistance settings, etc.

Vehicle settings menu

- Driver assistance
- Drive mode
- Cluster
- Lights
- Door
- Digital key
- Convenience

The information provided may differ depending on which functions are available to your vehicle.

WARNING

Do not adjust the Vehicle Settings while driving. You may be distracted from the driving task and could collide.

Setting your vehicle



1. Press the **SETUP** button on the main keyboard.
2. Select **Vehicle** to change the settings for features.

i **Information**

The infotainment system may change after software updates. For more information, refer to the manual provided in the infotainment system and the quick reference guide.

5. Convenience Features

Accessing your vehicle.....	5-5
Smart key.....	5-5
Immobilizer system.....	5-9
Hyundai Digital Key	5-10
Digital key (smartphone).....	5-10
Digital key (card key).....	5-15
Used vehicle/Digital key maintenance.....	5-18
Limitations of the system	5-19
Door locks	5-19
Operating door locks from outside the vehicle	5-19
Operating door unlocks from inside the vehicle	5-20
Auto Door lock/unlock features.....	5-22
Child-protector rear door locks	5-22
Theft-alarm system	5-23
Rear Occupant Alert (ROA)	5-24
Steering wheel	5-25
Motor Driven Power Steering (MDPS).....	5-25
Tilt/Telescopic steering.....	5-25
Steering wheel heater.....	5-26
Horn	5-27
Mirrors	5-28
Inside rearview mirror.....	5-28
Outside rearview mirrors.....	5-29
Windows.....	5-31
Power windows.....	5-31
Sunroof	5-34
Sunshade	5-35
Tilt open/close.....	5-35
Slide open/close	5-36
Automatic reversal.....	5-36
Resetting the sunroof	5-37
Sunroof open warning	5-38
Hood	5-38
Opening the hood	5-38
Closing the hood.....	5-39

Tailgate	5-39
Opening the tailgate	5-39
Closing the tailgate	5-40
Emergency tailgate safety release	5-40
Electric charging door	5-41
Opening the electric charging door	5-41
Closing the electric charging door	5-41
Vehicle system OTA update	5-42
Downloading software	5-42
Approving software update	5-42
Preparing software update	5-42
Updating software	5-43
Exterior lights	5-44
Lighting control	5-44
High beam operation	5-46
Turn signals and lane change signals	5-46
Rear fog light	5-47
Battery saver function	5-47
Headlight leveling device	5-47
Headlight delay function	5-48
Interior Lights Always On	5-48
Daytime Running Light (DRL)	5-49
Welcome system	5-49
High Beam Assist (HBA)	5-50
High Beam Assist settings	5-50
High Beam Assist operation	5-50
High Beam Assist malfunction and limitations	5-51
Interior lights	5-52
Interior lamp AUTO off	5-52
Front lights	5-52
Rear lamps	5-53
Vanity mirror lamp	5-54
Mood lamp	5-54
Cargo area lamp	5-54
Wipers and washers	5-55
Front windshield wipers	5-55

5. Convenience Features

Front windshield washers	5-56
Rear windshield wipers and washers	5-57
Rear windshield washers.....	5-57
Automatic climate control system	5-58
Automatic heating and air conditioning.....	5-59
Manual heating and air conditioning.....	5-60
System operation.....	5-66
System maintenance	5-67
Windshield defrosting and defogging	5-69
Automatic climate control system.....	5-70
Defogging logic.....	5-70
Windshield defrosting (Heater)	5-71
Rear window defroster	5-71
Climate control additional features	5-72
Auto defogging system	5-72
Auto dehumidify	5-73
Recirculating air when washer fluid is used.....	5-73
Link to climate settings for auto-adjustment	5-74
Storage compartment.....	5-74
Center console storage	5-74
Glove box.....	5-75
Passenger seat open tray	5-75
Cargo tray	5-75
Interior features	5-76
Cup holder.....	5-76
Seatback board	5-76
Sunvisor	5-77
Power outlet	5-77
USB charger.....	5-78
Wireless smartphone charging system	5-79
Vehicle to load (V2L).....	5-80
Coat hook	5-81
Shopping bag hook.....	5-81
Upper garnish.....	5-82
Van package	5-82
Floor mat anchor(s).....	5-83

Cargo area cover	5-84
Cargo security screen	5-84
Exterior features.....	5-85
Roof side rails	5-85
Roof basket	5-86
Infotainment system.....	5-87
USB Port	5-87
Antenna	5-88
Steering wheel remote controls.....	5-88
Infotainment system	5-89
Voice recognition	5-89
Bluetooth® wireless technology.....	5-89

Accessing your vehicle

Smart key



- (1) Door lock
- (2) Door unlock
- (3) Remote start
- (4) Tailgate unlock

Your HYUNDAI uses a smart key that is used to lock or unlock the driver's and passenger's doors and the rear tailgate, and start the vehicle.

Locking your vehicle (1)



1. Close all doors, hood, and tailgate.
2. Have the smart key with you.
3. Press the door handle button or press the Door Lock button (1) on the smart key. The hazard warning lights blink.
4. Make sure the doors are locked by pulling the outside door handle.

i Information

- To fold the outside rearview mirror simultaneously when the door is locked, Select **User Settings > Convenience > Welcome Mirror/Light > On door unlock/On driver approach** in the instrument cluster or **Vehicle > Light > Welcome mirror/light > On driver approach** in the infotainment system.
- The door handle button only operates when the smart key is within 1 m (40 in.) from the outside door handle.
- If you lock the doors using the door handle button, the doors are not locked under the following circumstances:
 - The smart key is in the vehicle.
 - The Start/Stop button is in the ACC or ON position.
 - Any door is open.

If this occurs, a chime sounds for a few seconds. Check the vehicle before attempting to lock the vehicle again.

i Information

Before you leave your vehicle with the smart key, verify that your vehicle is locked.

(If it has been longer than 3 seconds, verify the doors are locked by pressing the lock button on the smart key. You can hear a single beep.)

WARNING

Do not leave the smart key in your vehicle with children that are unattended or unsupervised.

Children could unintentionally press the Start/Stop button or could operate the power windows or other vehicle controls or even cause the vehicle to move. This may result in serious injury or death.

Unlocking your vehicle (2)



1. Have the smart key with you.
2. Press the door handle button or press the Door unlock button (2) on the smart key. The hazard warning lights blink.

i Information

- To unfold the outside rearview mirror simultaneously when the door is unlocked, Select **User Settings > Convenience > Welcome Mirror/Light > On door unlock/On driver approach** in the instrument cluster or **Vehicle > Light > Welcome mirror/light > On driver approach** in the infotainment system.
- After unlocking the doors, the doors are locked automatically after 30 seconds unless a door is opened.
- The infotainment system may change after software updates. For more information, refer to the manual provided in the infotainment system and the quick reference guide.

Smart key reminder

If the smart key is in the vehicle, and the door is locked with the central door lock/unlock button in the vehicle with a door open, the doors are not locked but unlocked again.

Remotely starting vehicle (3)

To start the vehicle remotely:

1. Press the door lock button on the smart key within about 10 m (32 ft.) from the vehicle.
2. Press the Remote Start button for more than 2 seconds within 4 seconds after pressing the door lock button.
3. The vehicle will start.
4. To turn off the remote start function, press the Remote Start button (3) once.

i Information

- The vehicle must be in P (Park) for the remote start function to start.
- The vehicle displays "**Smart key must be present to keep the vehicle running**" if you get on the vehicle without a registered smart key.
- The vehicle turns off if you do not get in the vehicle within 10 minutes after remotely starting the vehicle.
- The Remote start button (3) may not operate if the smart key is not within 10 m (32 ft.) from the vehicle.
- The vehicle does not remotely start if the hood or tailgate is open.

Unlocking the tailgate (4)

To unlock:

1. Carry the smart key.
2. Either press the tailgate handle button or press the Tailgate unlock button (4) on the smart key for more than one second.
3. The hazard warning lights will blink two times.

Once the tailgate is opened and then closed, the tailgate will lock automatically.

***i* Information**

The tailgate Unlock button (4) will only unlock the tailgate. It will not release the latch and open the tailgate automatically. If the Tailgate Unlock button is used, someone must still press the tailgate handle button to open the tailgate.

Mechanical key

If the Smart Key does not operate normally, you can lock or unlock the door by using the mechanical key.



Move the release lever in the direction of the arrow (1) and then remove the mechanical key (2). Insert the mechanical key into the key hole on the door.

To reinstall the mechanical key, put the key into the hole and push it until a click sound is heard.

Loss of a smart key

A maximum of two smart keys can be registered to a single vehicle. If you happen to lose your smart key, it is recommended that you should immediately take the vehicle and remaining key to your authorized HYUNDAI dealer or tow the vehicle, if necessary.

Smart key precautions

- The smart key may not work if any of the following occur:
 - The smart key is close to a radio transmitter such as radio station or airport that may interfere with normal operation of the transmitter.
 - The smart key is near a mobile two way radio system or a mobile phone.
 - Another vehicle's smart key is being operated close to your vehicle.
 - The smart key is near any normal electronic devices or credit cards.
 - The vehicle battery is discharged.
 - Connecting an external device to the power outlet and placing the smart key near the external device.

If the smart key does not work correctly, open and close the door with the mechanical key. To start the vehicle, press the Start/Stop button directly with the smart key. If you have a problem with the smart key, we recommend that you contact an authorized HYUNDAI dealer.

If the smart key is in close proximity to your mobile phone, the signal could be blocked by your mobile phone's normal operational signals. This is specifically relevant when the phone is active such as making and receiving calls, text messaging, and/or sending/receiving emails. When possible, avoid keeping the smart key and your smartphone in the same location such as a pants or jacket pocket to avoid interference between the two devices.

- If your windows are tinted, especially with metallic window tint, it may cause frequency interference, reducing the smart key operating range.

NOTICE

- Keep the smart key away from electromagnetic materials that blocks electromagnetic waves to the key surface.
- Always have the smart key with you when leaving the vehicle. If the smart key is left near the vehicle, the vehicle battery may be discharged.

Replacing the battery

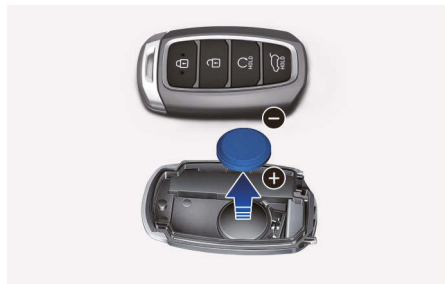

If the smart key is not working properly, try replacing the battery with a new one.

Battery type: CR2450

To replace the battery:

1. Remove the mechanical key.
2. Insert a flat head screwdriver into the inner groove to remove the smart key cover.
3. Remove the old battery and insert the new battery. Make sure the battery position is correct. An improperly positioned battery may discharge the battery, causing smart key failure.
4. Reinstall the rear cover of the smart key.

If you suspect your smart key might have sustained some damage or you feel your smart key is not working correctly, we recommended that you contact an authorized HYUNDAI dealer.

⚠ WARNING

This product contains a button battery. If swallowed, a lithium button battery can cause severe or fatal injuries within 2 hours. Keep batteries out of reach of children.

If you think batteries may have been swallowed or placed inside any part of the body, seek immediate medical attention.

***i* Information**

An inappropriately disposed battery may be harmful to the environment and human health. Always dispose of a used battery according to your local law(s) and regulations.

***i* Information**

For more information, refer to "IMPORTER & DISTRIBUTOR INFORMATION FOR EU BATTERY REGULATION (EU 2023/1542)" section in the owner's manual.

Immobilizer system

The immobilizer system helps protect your vehicle from theft. If an improperly coded key (or other device) is used, the vehicle is disabled.

When the Start/Stop button is in the ON position, the immobilizer system indicator should come on briefly, then go off. If the indicator starts to blink, the system does not recognize the coding of the key.

Press the Start/Stop button to the OFF position, then to the ON position again.

The system may not recognize your key's coding if another immobilizer key or other metal object (for example, key chain) is near the key. The vehicle may not start because the metal may interrupt the transponder signal from transmitting normally.

If the system repeatedly does not recognize the coding of the key, we recommend that you contact an authorized HYUNDAI dealer.

Do not attempt to modify this system or add other devices to it. Electrical problems may occur making your vehicle inoperable.

⚠ WARNING

To prevent theft of your vehicle, do not leave spare keys anywhere in your vehicle. Your immobilizer password is a customer unique password and should be kept confidential.

NOTICE

Avoid exposing the key to moisture, static electricity, and rough handling. The Immobilizer system may malfunction.

Hyundai Digital Key

 if equipped

Hyundai digital key provides convenience to the driver, which the driver can use to lock or unlock the driver and passenger doors or the tailgate and turn on the vehicle.

Digital key (smartphone)

i Information

- Hyundai digital keys are only available on smartphone that support digital key functions, and digital key functions of smartphones are provide by smartphone manufacturers.
- Available smartphone models can be found on smartphone manufactures' website or HYUNDAI website.
- Depending on the availability of service on the vehicle, some functions may not operated.

Setting your smartphone

To use the digital key (smartphone), download the Blue Link App and sign up Hyundai account and service.

For more information about Blue Link, refer to the infotainment system guide.

Registering your digital key (smartphone)

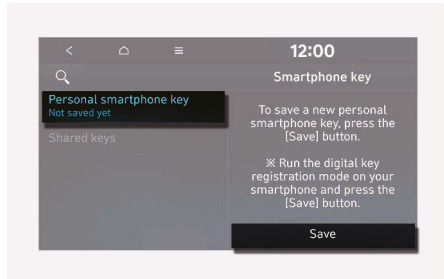

[A] Vehicle authentication pad (Wireless charging pad)

1. Turn on the vehicle with a smart key and have your smart keys with you in the vehicle.

i Information

For Europe, both smart keys must be in the vehicle to register the digital key.

2. Put the gear in P (Park), select **User Settings > Digital Keys > Smartphone Key** in the instrument cluster or **Settings > Vehicle > Digital key > Smartphone key > Personal smartphone Key** in the infotainment system Settings menu.,.
3. After selecting **Digital Key > Set Up Digital Key** from the Bluelink App in the smartphone, register the digital key according to the guidance in the smartphone screen.

- Ultra Wide Band unsupported smartphone
 - Place your smartphone on the vehicle authentication pad (wireless charging pad) with the screen facing up.
 - The NFC Antenna position on Samsung device can be found in the following path: **Settings > Connections > NFC and contactless payments.**
 - The NFC Antenna position on Google Pixel phone can be found in the following path: **Settings > Connected devices > Connection preference > NFC.**
 - The NFC Antenna position on Apple iPhone is located at the top of the rear [A] and Apple WATCH is located at the center of the screen [B].



- Ensure that the NFC Antenna position on the smartphone is in contact with the vehicle authentication pad (wireless charging pad).
- The location of the NFC Antenna on the smartphone may vary by phone model, so please contact the smartphone manufacturer for details.

4. Press **Save** button in the infotainment system to start registration.

When the digital key (smartphone) is saved, a message appears on the infotainment system.

i Information

- If you want to register a digital key (smartphone) again, refer to "Deleting your digital key (smartphone)" and delete the digital key (smartphone) before re-registering.
- During the digital key saving process, the process may cancel when:
 - The smartphone is removed from the vehicle authentication pad (wireless charging pad)
 - The infotainment system is changed
 - The vehicle is turned off
 - The gear is shifted
- The registering process does not start if both smart keys are not in the vehicle.
- Some smartphones may not start the registering process depending on the internal structure. Move the smartphone to the left or right on the vehicle authentication pad (wireless charger pad) and try registering the smartphone.

Using the digital key (smartphone)

Digital key touch control

The driver can lock or unlock the door by placing the smartphone on the outside door handle, and the vehicle can be started by placing the smartphone on the vehicle authentication pad (wireless charging pad).

i Information

The location of the NFC Antenna on the smartphone may vary by phone model, so please contact the smartphone manufacturer for details.

Digital key close proximity control

- If you have the smartphone in possession, the doors can be locked or unlocked without touching the smartphone to the door handle, but by touching the door lock/unlock sensor (engraved part) on the door handle. Also, the vehicle can be started by pressing the Start/Stop button without placing the smartphone on the vehicle authentication pad (wireless charging pad).
- When the smartphone and vehicle is connected by Bluetooth, the Door Lock/Unlock, Remote Start and tailgate open functions are available using the App provided by the smartphone manufacturer.

i Information

- The function is only available for Ultra Wide Band supported smartphone digital keys. To use the function, the smartphone's Bluetooth must be activated.
- The necessary distance between the smartphone and vehicle for Bluetooth connection may vary depending on the surroundings of the vehicle and smartphone.

- The Remote Start or Tailgate open function may not be available depending on the country or vehicle type (hybrid, plug-in hybrid or electric vehicle).

Locking/Unlocking the doors

- Ultra Wide Band unsupported smartphone

Apple iPhone / Samsung & Google Pixel smartphones

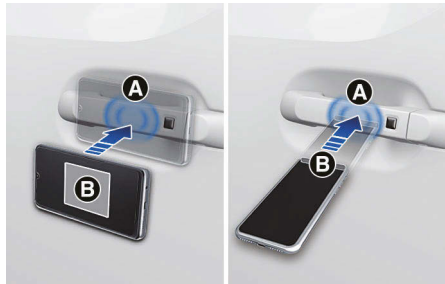

[A] Door handle authentication pad

[B] NFC Antenna

- If the driver places the digital key (smartphone) NFC antenna to the driver's or passenger's door handle authentication pad [A] for more than 2 seconds, the door locks or unlocks.
- Ultra Wide Band supported smartphone
 - If you touch the door lock/unlock sensor (engraved part) on the door handle with the smart phone in possession, the door locks or unlocks.
 - If you approach the front door handle with the smartphone in possession when **On driver approach** is set, the door unlocks automatically.
- After unlocking the doors, the doors are automatically re-locked after 30 seconds unless a door is opened.
- If the smartphone digital key does not operate, try again after moving the smartphone away from the door handle authentication pad (more than 0.1 m (4 in.)).

i Information

- You cannot lock your vehicle using the digital key (smartphone) if any of the following occurs:
 - The smart key is in the vehicle.
 - The Start/Stop button is in the ACC or ON position.
 - Any of the doors, hood, or tailgate are open.
- The door may not unlock automatically if you stay near the vehicle for several minutes with the Ultra Wide Band supported smartphone in possession.
- If the smartphone is kept in the back pocket or bag, it may cause poor Bluetooth connection, or the door lock/unlock or vehicle start-up operation may be delayed.

Starting the vehicle

- Ultra Wide Band unsupported smartphone
 - After placing your registered digital key (smartphone) on the vehicle authentication pad (wireless charging pad), depress the brake pedal and press the Start/Stop button.
 - After starting the vehicle, the digital key (smartphone) may be removed from the vehicle authentication pad (wireless charging pad).
 - NFC communication may not work for some smartphones depending on the internal structure of the smartphone. Move the smartphone to the left or right of the vehicle authentication pad (wireless charging pad) to operate.

- Ultra Wide Band supported smartphone
 - With the smartphone inside the vehicle, depress the brake pedal and press the Start/Stop button.

For more details on the basic way to start the vehicle, refer to the "Start/Stop button" section in chapter 6.

i Information

If a shared digital key (smartphone) is used for the first time, the activating time may take longer.

- Place the shared digital key (smartphone) on the door handle authentication pad until the vehicle door lock/unlock activates.
- If a shared digital key (smartphone) is first used on the vehicle authentication pad (wireless charger pad), the initial start of the vehicle may fail.
- If the door lock/unlock is activated once with the shared digital key (smartphone) or the vehicle is started with the digital key (smartphone) on the vehicle authentication pad, the digital key (smartphone) is registered in the vehicle.

WARNING

The vehicle can be started when the registered smartphone is placed on the vehicle authentication pad (wireless charging pad). Therefore, do not leave unsupervised children or people who are not aware of the system since it can result in serious injury or death. In addition, always have the registered smartphone with you to prevent vehicle theft when leaving the vehicle.

Deleting your digital key (smartphone)

Turn on the vehicle with a smart key. Have your smart key with you in the vehicle.

Deleting all registered digital key (smartphone)

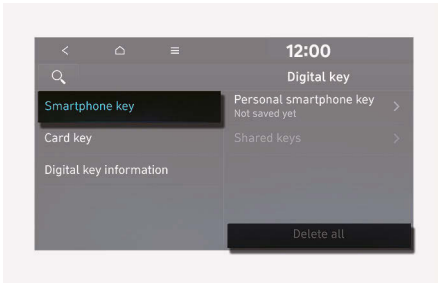

To delete all the registered digital key (smartphone), press the **SETUP** button, and then select **Vehicle > Digital key > Smartphone key > Personal smartphone key > Delete all** in the infotainment system.

- The "**Delete all**" button is disabled if there is no registered digital key (smartphone).

Deleting my registered digital key (smartphone)

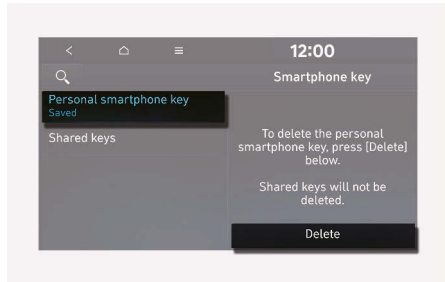

To delete only my registered digital key (smartphone), press the **SETUP** button, and then select **Vehicle > Digital key > Smartphone key > Personal smartphone key > Delete** in the infotainment system or select **User Setting > Digital Keys > Smartphone Key > Delete** in the instrument cluster.

- If a shared digital key (smartphone) is registered, it cannot be deleted.
- A new smartphone can be registered after deleting the existing digital key (smartphone) from "**Personal smartphone key**" menu. (if equipped)

i Information

- If the registered digital key (smartphone) is deleted, the digital key saved in the smartphone is also deleted.
- If the digital key is deleted from the smartphone, the digital key (smartphone) registered in the vehicle is also deleted.
- The shared digital key registered in the vehicle cannot be deleted individually.
- Even though the BlueLink App is deleted from the smartphone, the digital key saved in the smartphone is not deleted.
- Management of the digital key saved in the smartphone is available from the Digital Key App provided by the smartphone manufacturer.

Digital key (card key)

How to register Digital key (card Key)

To use the card key as a digital key, follow the following procedure.

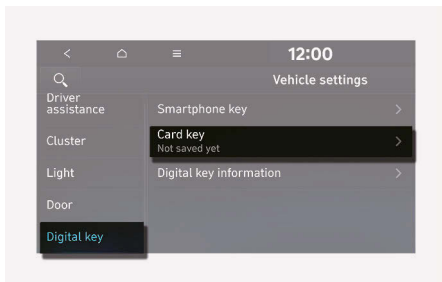

[A] Vehicle authentication pad (Wireless charging pad)

1. Have both of your smart keys with you in the vehicle.
2. Press the **SETUP** button, and then select **Vehicle > Digital key > Card Key**, and check whether **Enabled card key** in the infotainment system or select **User Setting > Digital Keys > Card Key** in the instrument cluster.
3. Place your card key on the vehicle authentication pad (wireless charging pad) while the vehicle is on.
4. Register your card key by pressing the **SETUP** button, and then selecting **Vehicle > Digital key > Card key > Save** in the infotainment system or select **User Setting > Digital Keys > Card Key > Save** in the instrument cluster.

i Information

- When there is a digital key (card key) already registered in the vehicle, a new digital key (card key) cannot be registered. Re-register a new digital key (card key) after deleting the exiting digital key (card key).
- To register a digital key (card key), both of your smart keys must be in the vehicle.
- A registered digital key (card key) cannot be registered in other vehicles.

Using the digital key (card key)

The driver can lock or unlock the door by placing the card key on the outside door handle, and the vehicle can be started by placing the card key on the vehicle authentication pad (wireless charging pad).

• Locking/Unlocking the doors

- If the driver places the digital key (card key) to the driver's or passenger's door handle authentication pad for more than 2 seconds, the door locks or unlocks.
- After unlocking the doors, the doors are automatically re-lock after 30 seconds unless a door is opened.

i Information

You cannot lock your vehicle using the digital key (card key) if any of the following occurs:

- The smart key is in the vehicle.
 - The Start/Stop button is in the ACC or ON position.
 - Any of the doors, hood, or tailgate are open.
-

• **Starting the vehicle**

After placing your registered digital key (card key) on the vehicle authentication pad (wireless charging pad), depress the brake pedal and press the Start/Stop button.

For more details on the basic way to start the vehicle, refer to the "Start/Stop button" section in chapter 6.

! WARNING

The vehicle can be started when the registered card key is placed on the vehicle authentication pad (wireless charging pad). Therefore, do not leave unsupervised children or people who are not aware of the system since it can result in serious injury or death. In addition, always have the registered card key with you to prevent vehicle theft when leaving the vehicle.

NOTICE

- The digital key (card key) may not work under the following conditions:
 - The digital key (card key) is not placed on the door handle authentication pad or vehicle authentication pad (wireless charging pad) correctly.
 - The digital key (card key) is near NFC-enabled cards such as credit cards or smartphones.

If the digital key (card key) does not work, try again after moving the digital key (card key) away from the door handle authentication pad (more than 0.1 m (4 in.)).
 - The digital key (card key) can be damaged by impacts. If the digital key (card key) is damaged, replace the digital key (card key) with a new one and register it again.
 - Long-time exposure to high temperature may cause the digital key (card key) to malfunction. Be careful not to expose the digital key (card key) to direct sunlight or high temperature.
 - Leaving the digital key (card key) on the in-vehicle authentication pad (wireless charging pad) while driving may cause the digital key (card key) to malfunction. Remove the digital key (card key) from the in-vehicle authentication pad (wireless charging pad) after starting the vehicle.
 - Remove the digital key (card key) from the smartphone before charging the smartphone. If the digital key (card key) is placed between the smartphone and the in-vehicle authentication pad (wireless charging pad) while the smartphone is being charged, the digital key (card key) may malfunction. For example, when charging smartphone while the digital key (card key) is attached to the back of the smartphone case.
-

Deleting your digital key (card key)

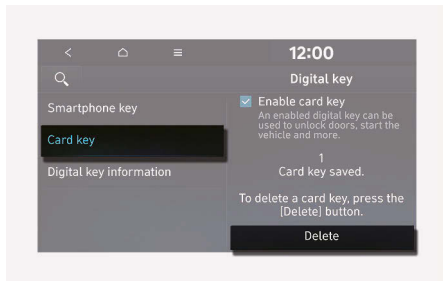

1. Turn on the vehicle with a smart key. Have your smart key with you in the vehicle.
2. From the infotainment system, press the **SETUP** button, and then select **Vehicle > Digital key > Card key > Delete** or select **User Setting > Digital Keys > Card Key > Delete** in the instrument cluster.
 - The **Delete** button is disabled if there is no digital key (card key) registered.

Personalized profile and vehicle settings

You can set the registered digital key (smartphone) profiles for Driver 1 and Driver 2. When you use the digital key (smartphone), the vehicle can be set to the user-defined personalized profile (includes items such as vehicle settings and audio preferences).

Linking/Unlinking profile

How to link user profile

1. Press the **SETUP** button, and then select **User profile > Link digital key (smartphone)** in the infotainment system.
2. Select **Link** to connect the registered smartphone's digital key and the user's profile.
3. Follow the instructions according to the message on the infotainment system screen.

How to unlink user profile

Press the **SETUP** button, and then select **User profile**, and then deselect **Link digital key (smartphone)** in the infotainment system.

- Unlinking is possible only when user profile is linked.

i Information

- User profile cannot be linked to both Driver 1 and Driver 2 that are connected to single smartphone. Personalization operates with the recently linked user profile, and the previously linked user profile will be automatically cancelled.
- User profile link works only when the digital key is registered to the vehicle.
- Digital key (card key) cannot be linked with a user profile.
- If the user profile linked digital key in the smartphone is deleted, the digital key should be re-registered and personalized by linking the user profile again.

Vehicle personalization operation

- The personalization function linked with digital key works when the profile linked smartphone is placed on the outside door handle authentication pad to lock or unlock the doors.
- The profile set by the digital key can be changed manually from the infotainment system.
- The personalization function using the digital key can be operated after linking the digital key in the infotainment system profile menu.
- The personalization function works only when the vehicle is OFF or when the vehicle is started remotely. If the vehicle is not started remotely, the personalization function does not work with the digital key.

i Information

User profile operation according to door lock/unlock system is as follows:

Item	Personalization Operation
Initial value	Guest
Profile linked smartphone key	Linked profile
Profile unlinked smartphone key	Recently activated profile
NFC card key	
Smart key	

Used vehicle/Digital key maintenance

Purchasing used vehicle

When purchasing a used vehicle, make sure to delete the smartphone key and card key registered by the previous user. If the card key comes with the vehicle, check whether it operates properly.

Digital Key maintenance

If you need to repaired or replaced your Digital Key system, make sure your smartphone key is still active. You may have to pair your phone again using the Bluelink app.

Limitations of the system

- HYUNDAI Digital Key may not operate if any of the following occurs:
 - Smartphone battery or the vehicle battery is discharged.
 - NFC or Bluetooth is turned off on the smartphone settings.
 - A credit card is near your smartphone, or a metal or thick smartphone case is used.
 - The card key is in a wallet or card holder, or overlapped with other cards.
 - There is electronic interference by other vehicles, objects, etc.
 - If you use a smartphone cover that uses wireless communication or is made of metal, remove the smartphone cover.
- The vehicle may not be controlled by the smartphone if any of the following occurs:
 - Other smartphone functions (calls, urgent calls, audio or NFC payment), apps, or wireless earphones are operating.
 - The Bluelink app function such as basic setting or app launching is limited by the prior policy according to the manufacturer.

Door locks

Operating door locks from outside the vehicle

Using the smart key

For more information, refer to the "Smart key" section in this chapter.

Using the mechanical key

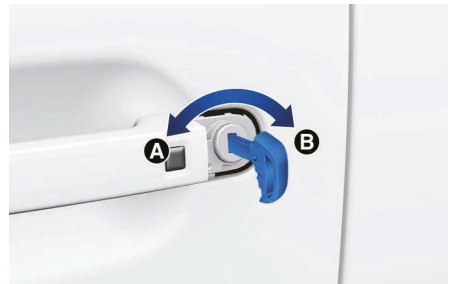

[A] Lock
[B] Unlock

To unlock:

1. Pull the door handle (1).
2. Press the release button (2) located inside the cover with a mechanical key.
3. Carefully pull out the cover (3) while continuing to press the release button to remove the cover and expose the key cylinder.

4. Insert the mechanical key into the key cylinder and rotate [B] clockwise to unlock the vehicle and counterclockwise [A] to lock the vehicle.

Once the doors are unlocked, they can be opened by pulling the door handle.

i Information

Only the driver's door can be locked/unlocked using the mechanical key.

NOTICE

- When removing the key cylinder cover, avoid scratching or breaking the plastic material.
- If the key cylinder cover freezes and cannot be removed easily, lightly tap on the cover or try to warm the cover by placing your hands around it and blowing warm air on it.
- Do not apply excessive force to the door and door handle.

i Information

- In cold and wet climates, door lock and door mechanisms may not work properly due to freezing conditions.
- If the door is locked/unlocked multiple times in rapid succession with either the vehicle key or door lock switch, the system may stop operating temporarily in order to protect the circuit and prevent damage to system components.

Operating door unlocks from inside the vehicle

With the door inside handle



Front door

If the inner door handle is pulled when the door is locked, the door is unlocked and opened.

Rear door

If the inner door handle is pulled once when the door is locked, the door is unlocked. If the inner door handle is pulled once more, the door is opened.

With the central door lock/unlock switch

Driver's door



When pressing the  portion (1) on the switch, all vehicle doors are locked.

- If any door is opened, the doors are not locked even though the lock switch (1) of the door is pressed.

- If the smart key is in the vehicle and any door is opened, the doors are not locked even though the lock switch (1) of the door is pressed.

When pressing the  portion (2) on the switch, all vehicle doors are unlocked.

In case of an emergency



In case of emergency such as when the battery is discharged, the only way to lock the door(s) is with the mechanical key from the outside key hole.

Doors without an outside key hole can be locked as follows:

1. Open the door.
2. Insert a small blade tool (for example, screwdriver or similar) into the emergency door lock hole and turn it clockwise for left side door, or turn it counterclockwise for right side door.
3. Close the door securely.

***i* Information**

If the electrical power door lock switch does not operate (for example, discharged vehicle battery) and the tailgate is closed, you cannot open the tailgate until power is restored.

WARNING

- Always close and lock the doors while the vehicle is moving. If the doors are unlocked, the risk of being thrown from the vehicle in a collision increases.

- Do not pull the inner door handle of the driver's or passenger's door while the vehicle is moving.

WARNING

Do not leave the elderly, children, or animals unattended in your vehicle. An enclosed vehicle can become extremely hot and the elderly, unattended children or animals who cannot escape the vehicle may be seriously injured or killed.

WARNING

Always park your vehicle properly. Depress the brake pedal, change the gear to P (Park), apply the parking brake, press the Start/Stop button to the OFF position, close all windows, lock all doors, and always take the keys with you.

WARNING

Be careful when opening doors and watch for vehicles, motorcycles, bicycles, or pedestrians approaching the vehicle to prevent serious injury or death.

***i* Information**

To exit the vehicle if the power door lock does not function:

- Operate the door unlock feature repeatedly (both electronic and manual) while simultaneously pulling on the door handle.
- Operate the other door locks and handles.
- Lower the driver's front window and use the mechanical key to unlock the door from outside.

Auto Door lock/unlock features

Your vehicle is equipped with features that automatically locks or unlocks your vehicle. (For Europe)

Your vehicle is equipped with features that automatically locks or unlocks your vehicle based on settings you select in the infotainment system. (For general)

Automatically Lock Enable on speed

All the doors are locked automatically when the vehicle exceeds 15 km/h (9 mph). (For Europe)

When this feature is set in the infotainment system, all the doors are locked automatically when the vehicle exceeds 15 km/h (9 mph). (For general)

Automatically Lock Enable on speed or shift

When this feature is set in the infotainment system, all the doors are locked automatically when the vehicle exceeds 15 km/h (9 mph) or when the vehicle is shifted out of P (Park) while the vehicle is running. (For general)

Automatically Unlock Enable on Shift to P

When this feature is set in the infotainment system, all the doors are unlocked automatically when the vehicle is shifted back to P (Park) while the vehicle is running.

Automatically Unlock Upon Vehicle Off

When this feature is set in the infotainment system, all the doors are unlocked automatically when the vehicle is turned off.

For detailed information, refer to the separately supplied infotainment system manual.

Additional unlock safety feature airbag deployment

As an additional safety feature, all doors are automatically unlocked when an impact causes the airbags to deploy.

Child-protector rear door locks



The child safety lock is provided to help prevent children seated in the rear from accidentally opening the rear doors.

The rear door safety locks must be used whenever children are in the vehicle.

The child safety lock is located on the edge of each rear door. When the child safety lock is in the lock position, the rear door does not open if the inner door handle is pulled.

To lock the child safety lock, insert a small flat blade tool (for example, screwdriver or similar) into the slot and turn it to the lock position as shown.

To allow a rear door to be opened from inside the vehicle, unlock the child safety lock.

⚠ WARNING

Never allow children to open the rear doors while the vehicle is moving. They may fall out of the vehicle. Make sure to use the rear door safety locks whenever children are in the vehicle.

Theft-alarm system

This system helps to protect your vehicle and valuables. The horn sounds and the hazard warning lights blinks continuously if any of the following occur:

- A door is opened without using the smart key.
- The tailgate is opened without using the smart key.
- The hood is opened.

The alarm continues for 30 seconds, then the system resets. To turn off the alarm, unlock the doors with the smart key.

The Theft Alarm System automatically sets 30 seconds after you lock the doors and the tailgate. For the system to activate, you must lock the doors and the tailgate from outside the vehicle by doing one of the following:

- Using the smart key.
- Pressing the button on the outside door handle with the smart key in your possession. (available with button type)
- Touching the touch sensor on the outside door handle with the smart key in your possession. (available with touch sensor type)

The hazard warning lights blink and the chime sounds once to indicate the system is armed.

Once the security system is set, opening any door, tailgate, or hood without using the smart key causes the alarm to activate.

The Theft Alarm System is not set if the hood, tailgate, or door is not fully closed. If the system is not set, check the hood, tailgate, or doors are fully closed.

Do not attempt to modify this system or add other devices to it.

i Information

- Do not lock the doors until all passengers have left the vehicle. If a door is opened after the system is armed, the alarm is activated.
- If the vehicle is not disarmed with the smart key, open the doors using the mechanical key and start the vehicle by pressing the Start/Stop button with the smart key.
- If the system is disarmed by unlocking the vehicle, and a door or the tailgate is not opened within 30 seconds, the doors are relocked and the system is rearmed automatically.

Rear Occupant Alert (ROA)

Rear Occupant Alert is provided to help prevent the driver from leaving with any rear passenger left in the vehicle.

System setting

To use Rear Occupant Alert, it can be enabled in the instrument cluster or infotainment system.

Select **User Settings > Convenience > Rear Occupant Alert** in the instrument cluster or **Vehicle > Convenience > Rear occupant alert** in the infotainment system.

i Information

The infotainment system may change after software updates. For more information, refer to the manual provided in the infotainment system and the quick reference guide.

System operation

When you turn off the vehicle and open the driver's door after opening and closing the rear door, the "**Check rear seats for passengers and belongings**" warning message appears on the instrument cluster.

WARNING

Always check the rear seats before you leave the vehicle.

The Rear Occupant Alert system does not actually detect the presence of objects or occupants in the rear seat but just informs you to check the rear seat by using the record of the rear door opening and closing.

i Information

The record of the rear door opening and closing resets only when the driver turns the vehicle off and locks the vehicle door. Even if the rear door has not been reopened, an alert may occur if the door record is not reset. For example, if the driver opens the door and exits the vehicle again without locking the door after the Rear Occupant Alert operates, the alert may occur again.

Steering wheel

Motor Driven Power Steering (MDPS)

The system assists you with steering the vehicle. If the vehicle is turned off or if the power steering system becomes inoperative, you can still steer the vehicle, but it requires increased steering effort.

If you notice any change in the effort required to steer during normal vehicle operation, we recommend that you contact an authorized HYUNDAI dealer.

NOTICE

If the Motor Driven Power Steering  warning light and the message "**Check Power Steering**" illuminates on the instrument, you can continue to steer the vehicle, but it requires increased steering effort. We recommend that you contact a HYUNDAI authorized repairer and have the system inspected as soon as possible.

i Information

During normal vehicle operation:

- The steering effort may be high immediately after pressing the Start/Stop button to the ON position.

This happens as the system performs the MDPS system diagnostics. When the diagnostics are completed, the steering wheel effort returns to its normal condition.

- When the battery voltage is low, you may have to use more effort to steer. This is a temporary condition and returns to normal condition after charging the battery.
- A click noise may be heard from the MDPS relay after the Start/Stop button is in the ON or OFF position.

- Motor noise may be heard when the vehicle is at a stop or driving at low speeds.
- When you operate the steering wheel in low temperatures, abnormal noise may occur. When the temperature rises, the noise disappears.
- When an error is detected from MDPS, the steering effort assist function is not activated. Instrument cluster warning lights may illuminate or the steering effort may be high. If these symptoms occur, drive the vehicle to a safe location as soon as possible. We recommend that your vehicle be inspected by an authorized HYUNDAI dealer as soon as possible.

Tilt/Telescopic steering

Adjust the steering wheel toward your chest, not toward your face. Make sure you can see the instrument cluster warning lights and gauges. After adjusting, push the steering wheel up and down to be in the locked position.

WARNING

Never adjust the steering wheel while driving. This may cause loss of vehicle control resulting in a collision.

NOTICE

While adjusting the steering wheel height, please do not push or pull it hard since the fixture can be damaged.

Manual adjustment



To adjust:

1. Pull down the lock release lever (1).
2. Adjust the steering wheel to the desired angle (2) and distance forward/back (3).
3. Pull up the lock release lever up to lock the steering wheel in place.

i Information

Sometimes the lock release lever may not engage completely. Pull down on the lock release lever, readjust the steering wheel again, and then pull back up on the lock release lever to lock the steering wheel in place.

Steering wheel heater

+ If equipped



When the Start/Stop button is in the ON position or when the vehicle is in the ready mode (READY indicator ON), press the steering wheel heater button to warm the steering wheel. The indicator on the button illuminates.

To turn the heated steering wheel off, press the button again. The indicator on the button will turn off.

The heated steering wheel will turn off automatically about 30 minutes after the heated steering wheel is turned on.

Link to climate settings for auto-adjustment

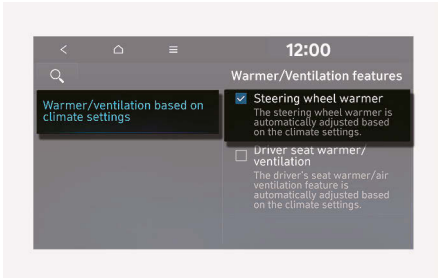

The temperature of the steering wheel warmer is automatically controlled depending on the inside and outside temperature of the vehicle when the vehicle is ON (READY indicator ON).

- Press the **SETUP** button, and then select **Vehicle > Seat > Warmer/Ventilation features > Warmer/ventilation based on climate settings**

i Information

The infotainment system may change after software updates. For more information, refer to the manual provided in the infotainment system and the quick reference guide.

NOTICE

- Do not install any cover or accessories on the steering wheel to prevent damage to the heated steering wheel system.
- Do not strike the steering wheel surface with a sharp-pointed object. This may damage the heating element in the steering wheel.

Horn



To sound the horn, press the area indicated by the horn symbol on your steering wheel (see illustration). The horn operates only when this area is pressed.

NOTICE

Do not strike the horn severely to or hit it with your fist. Do not press on the horn with a sharp-pointed object.

NOTICE

Do not clean the steering wheel surface with the following products:

- Organic solvents such as thinner, alcohol and gasoline
- Chemical products such as leather cleaner, coating agent, and wax

Mirrors

Inside rearview mirror

Before driving your vehicle, check to see that your inside rearview mirror is properly positioned. Adjust the rearview mirror so that the view through the rear window is properly centered.

WARNING

Make sure your line of sight is not obstructed. Do not place objects in the rear seat, cargo area, or behind the rear headrests that may interfere with your vision through the rear window.

WARNING

To prevent serious injury during a collision or deployment of the airbag, do not modify the rearview mirror and do not install a wide mirror.

WARNING

Never adjust the mirror while driving. This may cause loss of vehicle control and result in a collision.

NOTICE

When cleaning the mirror, use a paper towel or similar material dampened with glass cleaner. Do not spray glass cleaner directly on the mirror as this may cause the liquid cleaner to enter the mirror housing.

Day/night rearview mirror

 If equipped

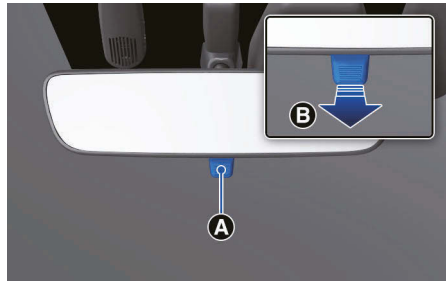

[A] Day
[B] Night

Before driving at night, pull the day/night lever toward you to reduce glare from the headlights of the vehicles behind you.

Remember that you lose some rearview clarity in the night position.

Electrochromic mirror

 If equipped



[A] Sensor

When the vehicle is ON (READY indicator ON), the glare from vehicle headlights behind you is automatically controlled by the sensor mounted in the rearview mirror.

When the gear is shifted to R (Reverse), the mirror automatically goes to the brightest setting in order to improve the driver's view behind the vehicle.

Outside rearview mirrors



Your vehicle is equipped with both left-hand and right-hand outside rearview mirrors. The mirrors can be adjusted with the mirror adjustment control switch. Adjust the rearview mirrors to your desired position before driving. The outside rearview mirrors can be folded to help prevent damage when going through an automatic car wash or when passing through a narrow street.

WARNING

The left and right outside rearview mirrors are convex. Objects seen in the mirror are closer than they appear.

Use the outside rearview mirror or turn your head and look to determine the actual distance of other vehicles prior to changing lanes.

WARNING

Do not adjust or fold the outside rearview mirrors while driving. This may cause loss of vehicle control resulting in a collision.

NOTICE

- Do not scrape ice off the mirror face. This may damage the surface of the glass.
- If the mirror is jammed with ice, do not adjust the mirror by force. Use an approved de-icer (not radiator antifreeze) spray, or a sponge or soft cloth with very warm water, or move the vehicle to a warm place and allow the ice to melt.
- Do not clean the mirror with harsh abrasives, fuel, or other petroleum based cleaning products.

Adjusting the outside rearview mirrors



Adjusting the outside rearview mirrors

1. Press the switch (1) to the L (left side) or R (right side) to select the outside rearview mirror you want to adjust.
2. Use the mirror adjustment control switch (2) to position the selected mirror up, down, left, or right.
3. After adjustment, press the switch (1) to the middle to prevent unintended adjustment.

NOTICE

- The mirrors stop moving when they reach the maximum adjusting angles, but the motor continues to operate while the switch is pressed. Do not press the switch longer than necessary, because this can damage the motor.
- Do not adjust the outside rearview mirrors by force to prevent damage to the motor.

Folding the Outside rearview mirrors

 If equipped



The outside rearview mirrors can be folded or unfolded by pressing the button.

- Enable on door unlock
Select **User Settings > Convenience > Welcome Mirror/Light > On door unlock** in the instrument cluster or deselect **Vehicle > Light > Welcome mirror/light > On driver approach** in the infotainment system.
 - The mirror folds or unfolds when the door is locked or unlocked using the smart key.
 - The mirror folds or unfolds when the door is locked or unlocked by the touching the touch sensor on the outside door handle.

- Enable on driver approach
Select **User Settings > Convenience > Welcome Mirror/Light > On driver approach** in the instrument cluster or **Vehicle > Light > Welcome mirror/light > On driver approach** in the infotainment system.

i Information

- The infotainment system may change after software updates. For more information, refer to the manual provided in the infotainment system and the quick reference guide.
- For your safety, the outside rearview mirrors cannot be folded automatically when driving at a speed of 15 km/h (9 mph) or faster.

NOTICE

To prevent unnecessary battery discharge, do not adjust the mirrors longer than necessary when the vehicle is not running.

NOTICE

Do not fold the electric type outside rearview mirror by hand. It may cause motor failure.

Windows



- (1) Driver's door power window switch
- (2) Front passenger's door power window switch
- (3) Rear door (left) power window switch
- (4) Rear door (right) power window switch
- (5) Power window lock switch

Power windows

The Start/Stop button must be in the ON position to be able to raise or lower the windows. Each door has a power window switch to control the door's window. The driver has a Power Window Lock button that can block the operation of rear passenger windows. The power windows operate for about 3 minutes after the Start/Stop button is in the ACC or OFF position. If the front doors are opened, the battery power is turned OFF and the power windows do not operate.

Window opening and closing

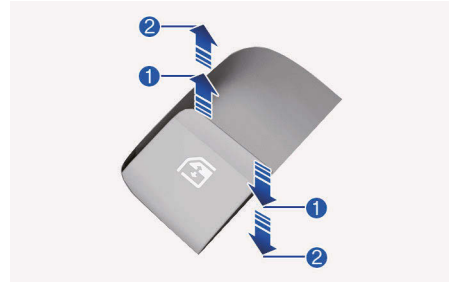

To open:

Press the window switch down to the first detent position (1). Release the switch when you want the window to stop.

To close:

Pull the window switch up to the first detent position (1). Release the window switch when you want the window to stop.

Auto up/down window

 if equipped

Pressing the power window switch momentarily to the second detent position (2) completely lowers or lifts the window even when the switch is released. To stop the window at the desired position while the window is operating, pull up or press down and release the switch.

WARNING

- Do not leave the vehicle running and the key in your vehicle with unsupervised children. Unattended children could operate the window, which could result in serious injury.
- Do not extend your head, arms or any other body parts or objects outside the window while driving to avoid serious injury.

Resetting the power windows

If the power windows do not operate normally, the automatic power window system must be reset as follows:

1. Press the Start/Stop button to the ON position.
2. Close the window and continue pulling up on the power window switch for at least one second.

If the power windows do not operate properly after resetting, we recommend that you contact an authorized HYUNDAI dealer.

WARNING

Make sure body parts or other objects are out of the way before closing the windows. The automatic reverse feature does not operate while resetting the power window system.

Automatic reversal



If a window senses any obstacle while it is closing automatically, it stops and lowers to allow the object to be cleared.

Information

- The automatic reverse feature is active only when the "Auto Up" feature is used by fully pulling up the switch to the second detent.
- The automatic reverse feature is inactive when the object's resistance is below a certain level, or if you pulling up the switch to the first detent.
- If the window detects any resistance while the power window switch is pulled up continuously, the window stops upward movement and then lowers about 2.5 cm (1 in.).
- If the power window switch is pulled up continuously again within 5 seconds after the window is lowered by the automatic window reverse feature, the automatic window reverse does not operate.

Please use with caution.

NOTICE

Do not install any accessories on the windows. The automatic reverse feature may not operate normally.

WARNING

Make sure body parts or other objects are safely out of the way before closing the windows to avoid injuries or vehicle damage.

Objects less than 4 mm (0.16 in.) in diameter caught between the window glass and the upper window channel may not be detected by the automatic reverse window and the window does not stop and reverse direction.

Power window lock button



The driver can disable the power window switches on the rear passenger doors by pressing the power window lock button. When the power window lock button is pressed:

- The driver's master control can operate all the power windows.
- The front passenger's control can operate the front passenger's power window.
- The rear passenger's control cannot operate the rear passenger's power window.

WARNING

Do not allow children to play with the power windows. Keep the driver's door power window lock button in the LOCK position. Serious injury or death may result from unintentional window operation by a child.

NOTICE

- To prevent possible damage to the power window system, do not open or close two windows or more at the same time. This also ensures the longevity of the fuse.
- Never try to operate the main switch on the driver's door and the individual door window switch in opposite directions at the same time. If this is done, the window stops and cannot be opened or closed.

Remote window opening/closing feature

 if equipped



- Press and hold the door lock button (1) for more than 3 seconds and the front windows move up after the doors are locked. Window movement stops when you release the door lock button.
- Press and hold the door unlock button (2) for more than 3 seconds and the front windows move down after the doors are unlocked. Window movement stops when you release the door unlock button.
- The Remote window opening/closing feature can be turned on and off in the infotainment system. Press the **SETUP** button, and the select **Door > Remote window control** to on or off.

i Information

- The remote window opening/closing feature operates only with the Safety Power Windows equipped.
- The remote window opening/closing feature may abruptly stop when you move away from your vehicle during operation. Stay in close proximity from your vehicle, while monitoring the window movement.
- One of the windows may stop operating when the window is interrupted by certain force. However, the other windows keep operating. Make sure that all windows are closed.
- The doors unlock when the windows are opened using the remote window open/closing feature.

⚠ WARNING

Always double check to make sure arms, hands, head and other obstructions are safely out of the way before using remote window closing feature.

NOTICE

Do not leave the windows down when leaving the vehicle to prevent theft or damage from water entering the vehicle.

Sunroof

+ if equipped

If your vehicle is equipped with a sunroof, you can slide or tilt your sunroof with the sunroof switch located on the overhead console.



The sunroof can only be operated when the Start/Stop button is in the ON or START position.

The sunroof can be operated for about 3 minutes after the Start/Stop button is in the ACC or OFF position. If the front door is open, the sunroof cannot be operated even within the 3 minute period.

⚠ WARNING

To prevent serious injury or death:

- Adjust the sunroof or sunshade when your vehicle stops.
- Do not leave the vehicle running and the key in your vehicle with unsupervised children. Unattended children could operate the sunroof.
- Do not sit on the top of the vehicle.

NOTICE

Do not sit on the top of the vehicle. It may cause injury or vehicle damage.

Sunshade



Use the power sunshade to block direct sunlight coming through the sunroof glass.

Open or close the sunshade by hand.

NOTICE

The sunshade opens automatically when the sunroof glass is opened, but the sunshade does not close automatically when the sunroof glass is closed. Also, only the sunshade cannot be closed when the sunroof glass is opened.

i Information

Do not pull the sunshade up or down, or apply excessive force as such action may damage the sunshade or cause it to malfunction.

Tilt open/close



(1) Tilt open

(2) Tilt close

- Push the sunroof switch upward, the sunroof glass tilts open.
- Push the sunroof switch forward when the sunroof glass is tilt opened, the sunroof glass closes.

The sunroof glass tilts open or closes while the switch is pushed.

i Information

The sunroof glass cannot slide open and tilt open at the same time. You cannot tilt the sunroof glass open while the sunroof glass is slide open. Also, you cannot slide the sunroof glass open while the sunroof is tilt open. Slide open or tilt open with the sunroof glass when the sunroof glass is completely closed.

Slide open/close



- Push the sunroof switch rearward, the sunshade and sunroof glass slide open. Push the sunroof switch forward, only the sunroof glass closes.
- Push the sunroof switch forward or rearward to the first detent position, the sunroof glass moves until the switch is released.
- Push the sunroof switch forward or rearward to the second detent position, the sunroof glass operates automatically (auto slide feature). The sunroof glass stops halfway (first detent position) before it is fully opened. To fully open the sunroof glass, push the sunroof switch rearward once more. At this time, the sunroof glass opens only while the switch is pushed.

To stop the sunroof movement at any point, push the sunroof switch in any direction.

i Information

To reduce wind noise while driving, we recommend that you drive at the recommended position (first detent position) before the maximum slide open position.

Automatic reversal



If the sunroof glass senses any obstacle while it is closing automatically, it will reverse direction then stop at a certain position.

The auto reverse function may not work if an object thin or soft is caught between the sliding sunroof glass and sunroof sash.

! WARNING

- Make sure heads, hands, arms or any other body parts or objects are out of the way before operating the sunroof. Body parts or objects may get caught causing injuries or vehicle damage.
- Never deliberately use your body parts to test the automatic reversal function. The sunroof glass may reverse direction, but there is a risk of injury.

NOTICE

- Do not continue to push the sunroof switch after the sunroof is fully opened, closed, or tilted. Damage to the sunroof motor could occur.
- Continuous operations such as slide open/close, tilt open/close, etc. may cause the motor or sunroof system to malfunction.
- Regularly remove any accumulated dust on the sunroof rail.
- Dust accumulated between the sunroof and roof panel can make noise. Open the sunroof and remove dust regularly using a clean cloth.
- Do not try to open the sunroof when the temperature is below freezing or when the sunroof is covered with snow or ice. The sunroof may not work properly and may break if opened by force.
- Do not open or drive with the sunroof glass open immediately after rain or washing the vehicle. Water may wet the interior of the vehicle.
- Do not extend any luggage outside the sunroof while driving. Vehicle damage may occur if the vehicle suddenly stops.

⚠ WARNING

Do not extend your head, arms, body parts or objects outside the sunroof while driving. Injuries may occur if the vehicle suddenly stops.

Resetting the sunroof

In some circumstances resetting the sunroof operation may need to be performed. Some instances where resetting the sunroof may be required include:

- When the 12 V battery is either disconnected or discharged
- When the sunroof fuse is replaced
- If the sunroof one-touch AUTO OPEN/CLOSE operation is not functioning properly

To reset the sunroof:

1. Start the vehicle in P (Park).
2. Make sure the sunroof glass is in the fully closed position. If the sunroof glass is open, push the switch forward until the sunroof glass is fully closed.
3. Release the switch when the sunroof glass is fully closed.
4. Push the switch forward until the sunroof glass moves slightly. Then release the switch.
5. Once again push and hold the sunroof switch forward until the sunroof glass slides open and close. Do not release the switch until the operation is completed.

If you release the switch during operation, start the procedure again from step 2.

i Information

If the sunroof does not reset when the vehicle battery is disconnected or discharged, or the sunroof fuse is blown, the sunroof may not operate normally.

Sunroof open warning



If the driver turns off the vehicle when the sunroof is not fully closed, the warning chime will sound for several seconds and the sunroof open warning will appear on the cluster display.

Close the sunroof securely when leaving your vehicle.

! CAUTION

Make sure the sunroof is closed fully when leaving your vehicle.

If the sunroof is left open, rain or snow may wet the interior of the vehicle. Also, leaving the sunroof open when the vehicle is unattended may invite theft.

Hood

Opening the hood

1. Park the vehicle and apply the parking brake.
2. Pull the hood release lever to unlatch the hood. The hood pops open slightly.



3. Go to the front of the vehicle, raise the hood slightly, push to the left the secondary hood release lever (1) inside of the hood center and lift the hood (2).

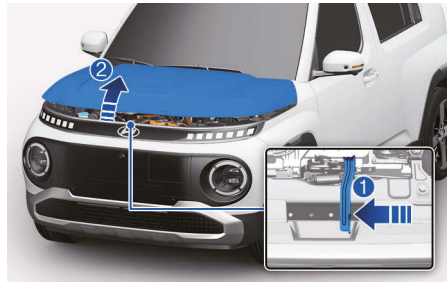

4. Pull out the stay rod and hold the hood opened with the stay rod.



WARNING

- Grasp the stay rod in the area wrapped in rubber. The rubber will help prevent you from being burned by hot metal when the motor is hot.
- The stay rod must be inserted completely into the hole provided whenever you inspect the motor compartment. This will prevent the hood from falling and possibly injuring you.

Closing the hood

1. Before closing the hood, check in and around the motor compartment to ensure the following:
 - Any tools or other loose objects have been removed.
 - All gloves, rags, or other combustible material have been removed.
 - All filler caps are tightly and correctly installed.
2. Lower the hood until it is about 30 cm (12 in.) above the closed position and then let it drop.
3. Check the hood has locked properly. If the hood is raised slightly, open it again and drop it from a little higher. Check again.

WARNING

- Before closing the hood, ensure all obstructions are removed from around the hood opening.
- Always double check to make sure that the hood is firmly latched before driving away. Check there is no hood open warning light or message displayed on the instrument cluster. Driving with the hood open may cause a total loss of visibility, resulting in a collision.
- Do not move the vehicle with the hood raised. It may block your vision and may result in a collision.

Tailgate

Opening the tailgate

Opening from outside



Make sure the vehicle is in P (Park) and apply the parking brake.

To open do one of the following:

- Unlock all doors with the Door Unlock button on your smart key. Press the tailgate open button and open the tailgate.
- Press and hold the tailgate open button on the smart key to unlock the tailgate. Then press the tailgate open button on the vehicle and open the tailgate.
- With the smart key in your possession, press the tailgate open button and open the tailgate.

Closing the tailgate

Lower the tailgate lid and press down until it locks. Always check it is secure by pulling on the handle.

WARNING

Always keep the tailgate completely closed while the vehicle is moving. If it is left open or ajar, poisonous exhaust gases containing carbon monoxide (CO) may enter the vehicle and serious injury or death may result.

WARNING

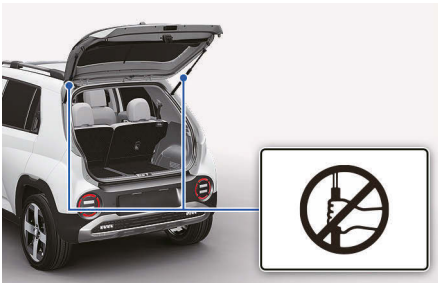

Always close the tailgate before driving. Do not grab or hold on to the tailgate support struts or they may be damaged. Deformation of the tailgate support struts may result in vehicle damage and personal injury.

WARNING

Never allow anyone to occupy the cargo area of the vehicle at any time. If the tailgate is partially or totally latched and the person cannot get out, serious injury or death may occur due to lack of ventilation, exhaust fumes, and rapid heat build-up, or due to exposure to cold weather conditions. The cargo area is also a very dangerous location in the event of a collision because it is part of the vehicle's crush zone.

Emergency tailgate safety release

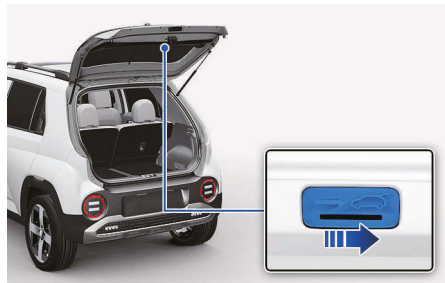

To unlock and open the tailgate manually from inside the cargo area, perform the following:

1. Insert a long, flat object, such as a key into the opening at the bottom of the tailgate.
2. Slide the latch in the direction of the arrow to unlock the tailgate.
3. Push the tailgate open.

WARNING

- Never allow anyone to occupy the cargo area of the vehicle at any time. The cargo area is a very dangerous location in the event of a collision because it is part of the vehicle's crush zone.
- Use the release lever for emergencies only.

Electric charging door

Opening the electric charging door

The charging door will not open if the vehicle doors are locked.

1. Turn the vehicle off.
2. With the vehicle door unlocked, press the symbol [A] to open the charging door.
 - The charging door opens.

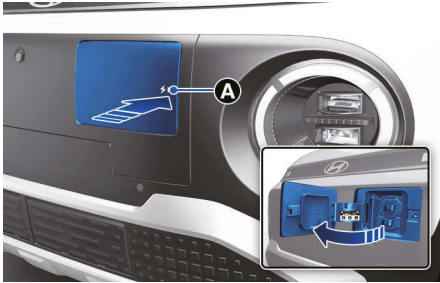

3. Open the charging inlet cover and charge the vehicle.

NOTICE

Do not pry on the charging door or use unauthorized tools to open the charging door.

Closing the electric charging door

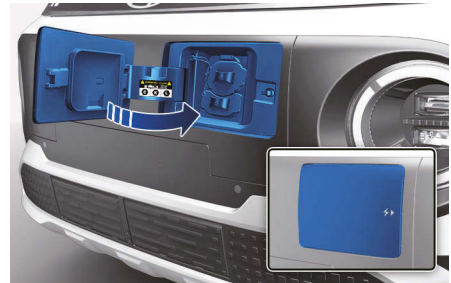

1. Close the charging inlet cover properly.
2. Close the charging door, press lightly to position it, and make sure it is securely closed.

For more information, refer to the "Charging your electric vehicle" section in chapter 1.

NOTICE

- If the charging door does not open or close because ice has formed around it, tap lightly or push on the door to break the ice and release the door.
- Make sure that the charging door is closed before driving the vehicle. If the charging door is opened, mechanical parts of the charging door can be damaged.
- After closing the charging door, be sure to check the warning light is off.
- After charging the vehicle, close the charging inlet properly. If not, the charging inlet and the charging door can be damaged.
- While washing the vehicle, do not spray high pressure water to the charging door directly. The high pressure can damage the charging door.
- Do not hold the hinge. It may damage the charging door.

Vehicle system OTA update

 If equipped

The OTA (Over-the-Air) software update feature allows you to wirelessly update software to the latest version. Using this feature, you can keep your vehicle system up to date with the latest software.

Information

The OTA software update feature is only available for Hyundai Blue Link users.

Downloading software

The latest software can be downloaded automatically while driving. After the latest software has been successfully downloaded, you receives a notification on your phone or the vehicle screen that the software update is available.

Approving software update

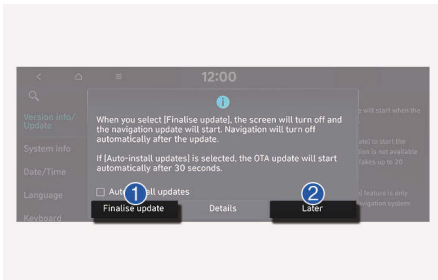

After the vehicle is turned off, the vehicle system allows you to start the update.

- To start the update, press **Finalise update** (1).
- To postpone the update, press **Later** (2).

Preparing software update

If you press the **Finalise update** button on the screen, the vehicle begins installing the update automatically. The following conditions must be satisfied:

- The vehicle must be off.
- The gear must be in P (Park).
- The Electronic Parking Brake (EPB) must be applied.
- The exterior lights must be turned off.
- The hood must be closed.
- The battery must be sufficient.
- The systems to be updated must not be running.

Information

The battery and system status are automatically checked by the vehicle.

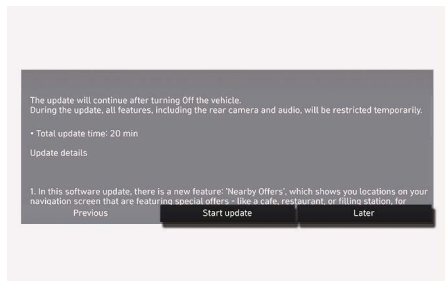

- To update immediately, press **Start update**.
- To cancel the update, press **Later**.

Updating software

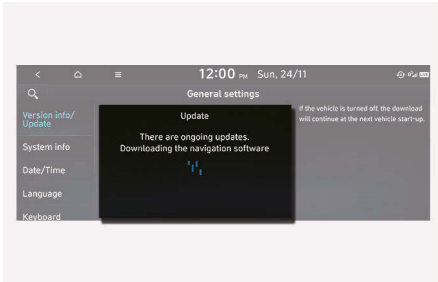

You can see the progress of the update on the screen.

After the update is complete, you receives a notification on your phone or the vehicle screen that the software update is complete.

i Information

The screen turns off automatically after 3 minutes to save the battery. If the screen turns off automatically, you can check the update progress by pressing the Start/Stop button.

i Information

- After the update starts, you can exit the vehicle.
- The update details may vary depending on the installed software version.
- Check the notice for the OTA software update on the HYUNDAI brand web.
- If the update fails, the update recovery will automatically proceed. If you want to retry the software update, even after a successful recovery, we recommend you to contact HYUNDAI.
- If the update or recovery fails, we recommend you to contact HYUNDAI Call Center.
- After the update is complete, it may provide new functions or improvements. For more information, see the "OTA Software Update" page on the HYUNDAI brand web or scan the QR code on the screen.

NOTICE

- Observe the following restrictions during the update.
 - You cannot use the vehicle during the update. Be sure to have enough time for the update, and safely park the vehicle before starting the update process.
 - You cannot use remote features, including remote start.
 - Vehicle charging is not available. Charge the vehicle after the update is complete.
 - The Rear Occupant Alert feature may not work. Check if there are any occupant in the rear seat.
 - If there is an update for the Hyundai Digital Key feature, the doors cannot be locked or unlocked using the digital key. If the Hyundai Digital Key feature is being updated, use the smart key to lock or unlock the doors.

- The update is automatically canceled if any vehicle conditions required for the update are changed before starting the update.
- Once the update has started, you cannot cancel the update.
- Note that the high-voltage-related modules for charging the 12 V battery may work during the update.
- You cannot use the OTA software update feature if you modify or replace any vehicle software.
- Do not open the hood or replace the battery in the vehicle during the update. The update may fail.
- If a diagnostic tool of any kind is connected to the vehicle OBD (On-board Diagnostic) terminal, the vehicle cannot be updated. The vehicle can be updated by removing the diagnostic tool connected to the OBD terminal and then restarting the vehicle.
- If the update is not complete successfully, we highly recommend you to contact HYUNDAI.

Exterior lights

Lighting control

To operate the lights, turn the knob at the end of the control lever to one of the following positions:

Type A

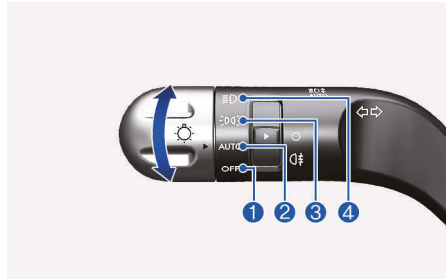

Type B

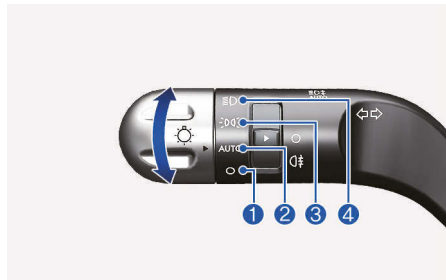

Type C

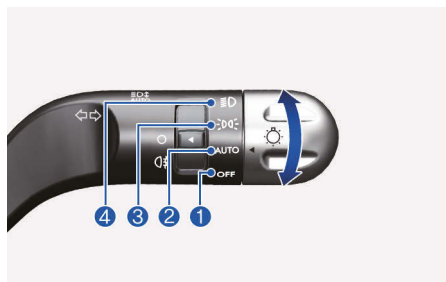

- (1) OFF (O)
- (2) AUTO light
- (3) Position light
- (4) Headlight

AUTO headlight



The position light and headlight are turned ON or OFF automatically depending on the amount of daylight as measured by the ambient light sensor [A] in front of the instrument panel.

Even with the AUTO headlight feature in operation, it is recommended to manually turn ON the headlights when driving at night or in a fog, driving in the rain, or when you enter dark areas, such as tunnels and parking facilities.

NOTICE

- Do not cover or spill anything on the sensor [A] located in front of the instrument panel.
- Do not clean the sensor using a window cleaner, the cleanser may leave a light film which could interfere with sensor operation.
- If your vehicle window tint or other types of metallic coating on the front windshield, the AUTO headlight system may not work properly.

Position light (☞☞)



The position light, license plate light, and instrument panel lamp are turned ON.

Headlight (☞☞)



The headlight, position light, license plate light and instrument panel lamp are turned ON.

i Information

The Start/Stop button must be in the ON position to turn on the headlight.

High beam operation



To turn on the high beam headlight, push the lever away from you (1). The lever returns to its original position.

The high beam indicator illuminates when the headlight high beams are switched on.

To turn off the high beam headlight, pull the lever towards you. The low beams turn on.

WARNING

Do not use high beam when there are other vehicles approaching you. Using high beam could obstruct the other driver's vision.

To flash the high beam headlight, pull the lever towards you (2), then release the lever. The high beams remain ON as long as you hold the lever.

Turn signals and lane change signals

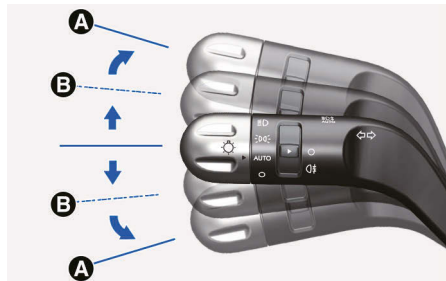

To signal a turn, push down on the lever for a left turn or up for a right turn in position [A].

If an indicator stays on and does not flash or if it flashes abnormally, one of the turn signal bulbs may be burned out and may require replacement. We recommend that you contact an authorized HYUNDAI dealer.

One touch turn signal

To use One touch turn signal, push the turn signal lever up or down to position [B] and then release it.

The lane change signals blink 3, 5, or 7 times.

You can enable the One touch turn signal function or choose the number of blinking by select **User Settings > Lights > One Touch Turn Signal > 7 flashes/5 flashes/3 flashes/Off** in the instrument cluster or **Vehicle > Light > One-touch turn indicator > 7 flashes/5 flashes/3 flashes/Off** in the infotainment system.

Rear fog light



To turn on the rear fog light:

Position the headlight switch in the headlight position, and then turn the headlight switch (1) to the rear fog light position.

To turn the rear fog lights off, do one of the following:

- Turn off the headlight switch.
- Turn the headlight switch (1) to the rear fog light position again.

Battery saver function

To prevent the battery from being discharging, the system automatically turns off the position light when the driver turns the vehicle off and opens the driver's door.

With this feature, the position lights turn off automatically if the driver parks on the side of road at night.

To keep the lights on when the vehicle is turned off:

1. Open the driver's door.
2. Turn the position lights OFF and ON again using the headlight switch.

Headlight leveling device

⁺ if equipped



To adjust the headlight beam level according to the number of the passengers and loading weight in the luggage area, turn the beam leveling switch.

The higher the number on the switch position, the lower the headlight beam level. Always keep the headlight beam at the proper leveling position, or headlights may dazzle other road users.

Listed below are examples of appropriate switch settings for varying loads. For loading conditions other than those listed, adjust the switch position to the most similar situation.

Loading condition	Switch position
Driver only	0
Driver + Front passenger	0
Full passengers (including driver)	1
Full passengers (including driver) + Maximum permissible loading	2
Driver + Maximum permissible loading	3

WARNING

If the function does not work properly, we recommend that the system be inspected by an authorized HYUNDAI dealer. Do not attempt to inspect or replace the wiring yourself.

Headlight delay function

If the Start/Stop button is in the ACC or OFF position with the headlights ON, the headlights (and/or position lights) remain on for about 5 minutes.

If the driver's door is opened and closed, the headlights are turned off after 15 seconds. Also, with the vehicle off if the driver's door is opened and closed, the headlights (and/or position lights) are turned off after 15 seconds.

The headlights (and/or position lights) can be turned off by pressing the lock button on the smart key twice or turning the headlight switch to the OFF or AUTO position.

You can enable the headlight delay function by select **User Settings > Lights > Headlight Delay** in the instrument cluster or **Vehicle > Light > Headlight time-out** in the infotainment system.

i **Information**

If the driver exits the vehicle through another door besides the driver's door, the battery saver function does not operate and the headlight delay function does not turn OFF automatically.

To avoid battery discharge, turn OFF the headlights manually from the headlight switch before exiting the vehicle.

Interior Lights Always On

 **If equipped**

The Interior Lights Always On function turns on the interior button lights regardless of the day or night condition. After the function is enabled, the Interior button lights are turned on or off in the following situations:

- When all doors are closed and locked, if you unlock the door, the interior button lights will illuminate for about 5 minutes.
- When the vehicle is turned off, the interior button lights are turned on for about 5 minutes. At this time, if you open and close the door or lock the doors, the interior button lights are turned off immediately.

Daytime Running Light (DRL)

The Daytime Running Lights (DRL) can make it easier for others to see the front of your vehicle during the day, especially after dawn and before sunset. The Daytime Running Lights (DRL) should be illuminated whenever you are driving during daylight hours. The DRL system will be ON when the headlamp stalk is in the OFF or the AUTO Position (when daylight is detected) and the Electronic Parking Brake (EPB) is released

Daytime running lights are disabled if:

- When vehicle is not starting.
- When the parking brake is activated.
- When the headlights are on.
 - However, the headlights are turned on automatically at night in the AUTO position of the light switch.
- When the front fog light is on (if equipped)

i Information

You can disable the daytime running lights by engaging the brakes with the headlights on and turning off the headlights.

Welcome system

Welcome system helps keep the driver visible by turning on vehicle lights when the driver approaches the vehicle.

Headlight and position light

When the headlight switch is in the headlight or AUTO position and all the doors (and tailgate) are closed and locked, the position lights and headlights come on for about 15 seconds when the door unlock button is pressed on the smart key.

If you press the door lock or unlock button, the position lights and headlights turn off immediately.

Select **User Settings > Lights > Headlight Delay** in the instrument cluster or **Vehicle > Light > Headlight time-out** in the infotainment system to turn on this function.

Interior light

When the interior light switch is in the  position and all doors (and tailgate) are closed and locked, the room lamps come on for 30 seconds when:

- The door unlock button is pressed on the smart key.
- The button of the outside door handle is pressed while carrying the smart key.
- You put your hand in the outside door handle while carrying the smart key.

If you press the door lock or unlock button on the smart key, the lights turn off immediately.

i Information

The infotainment system may change after software updates. For more information, refer to the manual provided in the infotainment system and the quick reference guide.

High Beam Assist (HBA)

 If equipped

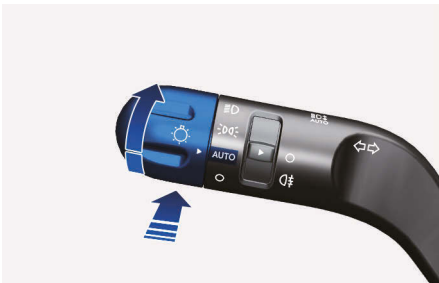

High Beam Assist automatically switches between high beam and low beam depending on the detected brightness from the lights of oncoming vehicles or vehicles in front.

Detecting sensor



(1) Front view camera

The front view camera is used as a detecting sensor to detect ambient light and brightness while driving.

Refer to the picture above for the detailed location of the detecting sensor.

NOTICE

- Always keep the front view camera in good condition to maintain optimal performance of High Beam Assist.
- For more information on the precautions of the front view camera, refer to the "Forward Collision-Avoidance Assist (FCA) (Front view camera only)" section in this chapter.

High Beam Assist settings

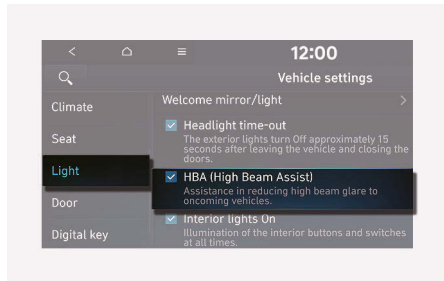

With the Start/Stop button in the ON position, Select **User Settings > Lights > High Beam Assist** in the instrument cluster or **Vehicle > Light > HBA (High Beam Assist)** in the infotainment system to turn on High Beam Assist and deselect to turn off the function.

WARNING

Only change the settings after parking your vehicle at a safe location.

High Beam Assist operation

- After selecting **HBA (High Beam Assist)** in the infotainment system to operate High Beam Assist:
 - Place the headlight switch in the AUTO position and push the headlight lever towards the instrument cluster. The High Beam Assist  indicator light illuminates.

- When High Beam Assist is enabled, high beams turn on when the vehicle speed is above 30 km/h (20 mph) and the High Beam (≡D) indicator illuminates. When the vehicle speed is below 20 km/h (12 mph), high beams do not turn on and the indicator light illuminates in white.
- When High Beam Assist is operating:
 - If the turn signal lever is pulled toward you when the high beams are off, the high beams turn on. When you let go of the turn signal lever, High Beam Assist operates again.
 - If the turn signal lever is pulled toward you when the high beams are on by High Beam Assist, the low beams turn on and High Beam Assist turns off.
 - If the turn signal lever is pushed away from you, the high beams turn on and High Beam Assist turns off.
 - If the headlight switch is moved from **AUTO** to another position (headlight/position/off), the corresponding light turns on and High Beam Assist turns off.
- When High Beam Assist is operating, high beam switches to low beam if:
 - The headlights of an oncoming vehicle are detected.
 - The tail lights of a front vehicle are detected.
 - The headlight or tail light of a motorcycle or a bicycle is detected.
 - The surrounding ambient light is bright enough so high beams are not required.
 - Streetlights or other lights are detected.

i Information

The images and colors in the instrument cluster may differ depending on the cluster type or theme selected in the infotainment system.

High Beam Assist malfunction and limitations

High Beam Assist malfunction

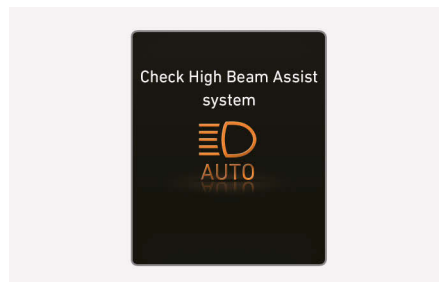

When High Beam Assist is not working properly, the "**Check High Beam Assist system**" warning message may appear, and the  warning light may illuminate on the instrument cluster. We recommend that the system be inspected by an authorized HYUNDAI dealer.

Limitations of High Beam Assist

High Beam Assist may not work properly in the following situations if:

- The headlights from an oncoming or front vehicle is damaged or out of the detection range.
- The headlights from an oncoming or front vehicle are covered with dust, snow, or water.
- An oncoming or front vehicle's headlights are off but the fog lights are on.
- There are lights that have a similar shape as a vehicle's light ahead.
- The headlights are not repaired or replaced properly.
- The headlights are not aimed properly.
- You are driving on a narrow curved road, rough road, uphill, or downhill.
- A front vehicle is partially visible at a crossroad or on a curved road.

- There is a temporary reflector or flash ahead (construction area).
- There is a traffic light, reflecting sign, LED sign, or reflectors ahead.
- The road is wet or covered with snow or ice.
- A vehicle suddenly appears from a curve.
- The vehicle is tilted due to a flat tire or being towed.
- The headlights from an oncoming or front vehicle is not detected because of exhaust fumes, smoke, fog, snow, blizzard, water spray on the road, or windshield condensation, etc.

i Information

For more information on the limitations of the front view camera, refer to the "Forward Collision-Avoidance Assist (FCA) (Front view camera only)" section in chapter 7.

! WARNING

- Always check road conditions, and if necessary, take appropriate actions to drive safely. It is your responsibility to operate your vehicle in a safe manner.
- If High Beam Assist does not operate properly, use the turn signal lever to switch between high beam and low beam.
- High Beam Assist may not operate for 15 seconds right after your vehicle is started or when the front view camera is initialized.

Interior lights

! WARNING

Do not use the interior lights when driving in the dark. The interior lights may obscure your view and result in a collision.

Do not use the interior lights for extended periods when the vehicle is turned off. Otherwise, the battery discharges.

Interior lamp AUTO off

The interior lights automatically go off about 20 minutes after the vehicle is turned off and the doors are closed. If a door is opened, the light go off 25 minutes after the vehicle is turned off. If the doors are locked by the smart key and the vehicle enters the armed stage of the theft alarm system, the lights go off 5 seconds later.

Front lights

Type A





Type B



- Press the lens to turn on or off the map lamp. (Type B)

This light produces a spot beam for convenient use as a map lamp at night or as a personal lamp for the driver and the front passenger.

- : Press the button to turn on the room lamp for the front and rear seats.
- : Press the button to turn off the room lamp for the front and rear seats.
- : The front or rear room lamps come on when the front or rear doors are opened. When doors are unlocked by the smart key, the front and rear lamps come on for about 30 seconds as long as any door is not opened. The front and rear room lamps go out gradually after about 30 seconds when the door is closed. However, if the Start/Stop button is in the ON position or all doors are locked, the front and rear lamps turn off. If a door is opened with the Start/Stop button in the ACC or OFF position, the front and rear lamps stay on for about 10 minutes.

Rear lamps



Type A



- : Press the button to turn on and off the rear room lamp.

Type B





- : Press the button to turn on and off the rear room lamp.
- : The room lamps come on when doors are opened. The room lamps go out when the door is closed.
- : Press the button to turn on and off the room lamp.

Vanity mirror lamp

 if equipped



Push the switch to turn the lamp on or off.

- : The lamp turns on if this button is pressed.
- : The lamp turns off if this button is pressed.

Mood lamp

 if equipped



[A] Door
[B] Crash pad

To set the brightness and color of the ambient light, Select **User Settings > Lights > Ambient Lighting** in the instrument cluster or **Vehicle > Light > Ambient light** in the infotainment system.

- If you do not want to use ambient lighting, set **Brightness** to **0** in the infotainment system.

Information

- The infotainment system may change after software updates. For more information, refer to the manual provided in the infotainment system and the quick reference guide.
- The color of the ambient light may seem different under some conditions depending on the color of the interior and the set mood color.

Cargo area lamp

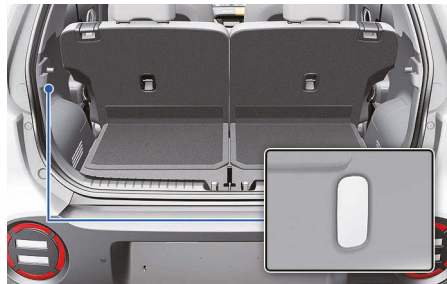

The cargo area lamp turns on when the tailgate is opened and off when the tailgate is closed.

NOTICE

Close the tailgate after use to prevent unnecessary battery discharge.

Wipers and washers

Front windshield wipers

Front windshield wiper/washer - Type A

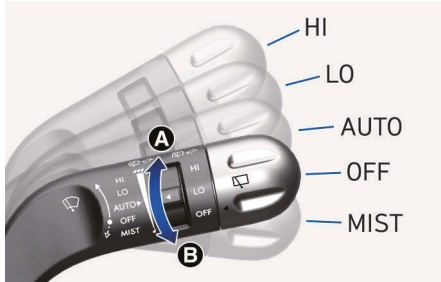

Front windshield wiper/washer - Type B

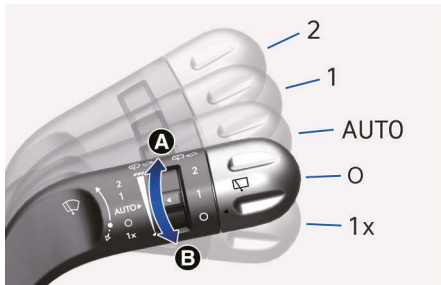

Front windshield wiper/washer - Type c

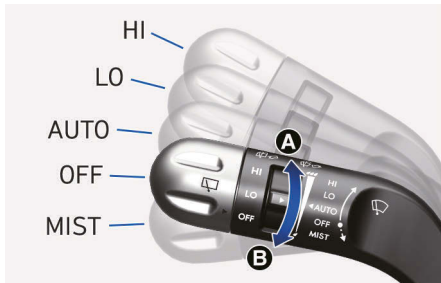

- [A] Increase AUTO mode sensitivity
[B] Decrease AUTO mode sensitivity

Operates as follows when the vehicle is turned on.

- **HI/2:** The wiper runs at a higher speed.
- **LO/1:** The wiper runs at a lower speed.

- **INT:** Intermittent wipe.

AUTO (if equipped): Wiper operates intermittently at the same wiping intervals. To vary the speed setting, turn the speed control knob.

- **OFF/O:** Wipers are not in operation.
- **MIST/1x:** For a single wiping cycle, push the lever downward and release. The wipers operate continuously if the lever is held in this position.

i Information

If there is heavy accumulation of snow or ice on the windshield, defrost the windshield for about 10 minutes, or until the snow and/or ice is removed to prevent damage to the wiper and washer system.

AUTO (Automatic) control

+ if equipped



The rain sensor located on the upper end of the windshield glass senses the amount of rainfall and controls the interval of the wiping cycle.

To change the sensitivity setting, turn the sensitivity control knob.

If the wiper switch is set in the AUTO mode when the Start/Stop button is in the ON position, the wiper operates once to perform a self-check of the system. Set the wiper to the **OFF/O** position when the wiper is not used.

WARNING

To prevent personal injury:

- Do not touch the upper end of the windshield glass facing the rain sensor.
- Do not wipe the upper end of the windshield glass with a damp or wet cloth.
- Do not put pressure on the windshield glass.

NOTICE

- When washing the vehicle, set the wiper switch in the **OFF/O** position to stop the auto wiper operation.
- Do not remove the sensor cover located on the upper end of the passenger side windshield glass.

Front windshield washers



In the **O(OFF)** position, pull the lever gently toward you to spray washer fluid on the windshield and to run the wipers 1-3 cycles. The spray and wiper operation continues until you release the lever. If the washer does not work, you may need to add washer fluid to the washer fluid reservoir.

Recirculating air when washer fluid is used

When washer fluid is used, in order to reduce any objectionable scent of the washer fluid from entering the cabin, recirculation mode and air conditioning are automatically activated depending on the outside temperature. If you select fresh mode while the function is operating, the function resumes after a certain amount of time. It may not work in some conditions such as cold weather or vehicle OFF.

For more information, refer to the "Climate control additional features" section in this chapter.

WARNING

When the outside temperature is below freezing, always warm the windshield using the defroster to help prevent the washer fluid from freezing on the windshield and obscuring your vision that could lead to a collision resulting in serious injury or death.

Always use appropriate washer fluids in the winter season or cold weather.

NOTICE

To prevent damage:

- Do not operate the washer when the fluid reservoir is empty or when the windshield is dry.
- Do not operate the wipers when the windshield is dry.
- Do not attempt to move the wipers manually.
- Use anti-freezing washer fluids in the winter season or cold weather.

Rear windshield wipers and washers



The rear window wiper and washer switch is located at the end of the wiper and washer switch lever. Turn the switch to the desired position to operate the rear wiper and washer.

- **2/HI:** High wiper speed
- **1/LO:** Low wiper speed
- **O/OFF:** Off

Auto rear wiper

The rear wiper operates while the vehicle is in reverse with the front wiper on.

You can select the function by select **User Settings > Convenience > Auto Rear Wiper (in R)** in the instrument cluster or **Vehicle > Convenience > Auto rear wiper (reverse)** in the infotainment system.

For more information, refer to the "Recirculating air when washer fluid is used" section in chapter 5.

Rear windshield washers

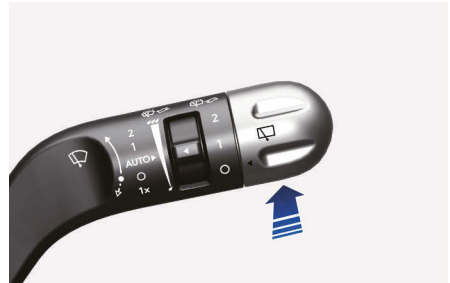

Push the lever away from you to spray rear washer fluid and to run the rear wipers 1-3 cycles. The spray and wiper operation continues until you release the lever.

Automatic climate control system

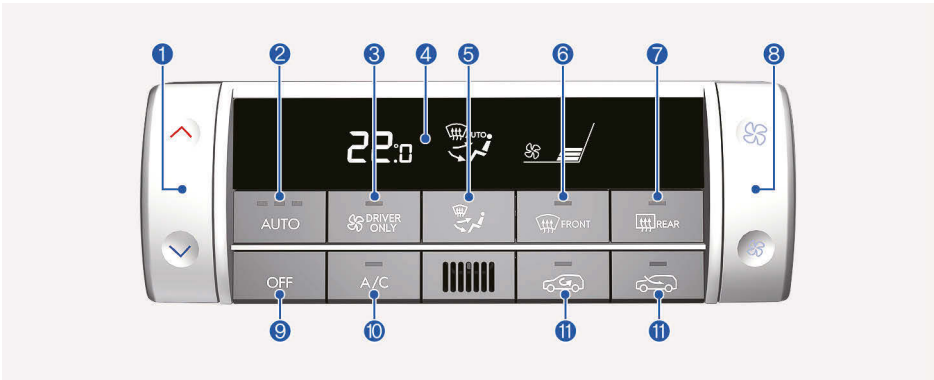

The climate control system buttons may differ depending on vehicle specification.

- (1) Temperature control
- (2) AUTO (automatic control)
- (3) DRIVER ONLY
- (4) Climate control information
- (5) Mode selection
- (6) Front windshield defroster
- (7) Rear window defroster
- (8) Fan speed control
- (9) OFF
- (10) A/C (air conditioning)
- (11) Air intake control

Automatic heating and air conditioning

The Automatic Climate Control System is controlled by setting the desired temperature.

1. With the vehicle ON, press the **AUTO** button. The modes, fan speeds, air intake, and air conditioning are controlled automatically by the temperature setting.

You can control the fan speed in three stages by pressing the **AUTO** button during automatic operation.

- **HIGH:** Provides rapid air conditioning and heating with the maximum fan speed setting range.
- **MEDIUM:** Provides air conditioning and heating with the mid-level fan speed setting range.
- **LOW:** Fan speed is set to the lowest setting range.



2. Push up or down the temperature control switch to set the desired temperature. If the temperature is set to the lowest setting, the air conditioning system operates continuously. After the interior has cooled sufficiently, adjust the switch to a higher temperature set point whenever possible.



To turn off the automatic operation, select any switch of the following:

- Mode selection switch
- Front windshield defroster button
- Fan speed control switch
- Front windshield defroster

The selected function is controlled manually while other functions operate automatically.

For your convenience and to improve the effectiveness of the climate control, use the **AUTO** button and set the temperature to 22 °C (72 °F).

NOTICE





Never place anything near the sensor to ensure better control of the heating and cooling system.

Manual heating and air conditioning

1. With the vehicle ON, set the mode selection switch to the desired position.

i Information

For improving the effectiveness of heating and cooling, select:

- Heating: 
- Cooling: 

2. Set the temperature control to the desired temperature.
3. Set the air intake control to the outside (fresh) air position.
4. Set the fan speed control to the desired speed.
5. If air conditioning is desired, turn on the air conditioning system.
6. Press the **AUTO** button to convert to full automatic control of the system.

Mode selection



The mode selection switch controls the direction of the air flow through the ventilation system.

Air flow direction



Left-hand drive

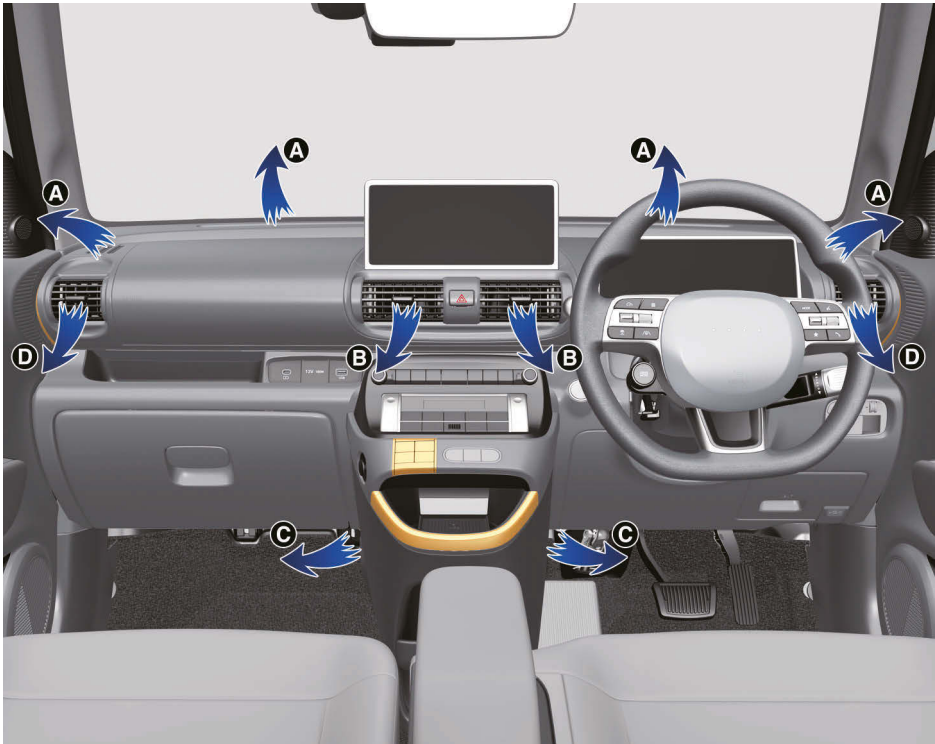

Right-hand drive



Symbol	Operation	Direction
	Air flow is directed toward the upper body and face. Additionally, each outlet can be controlled to direct the air discharged from the outlet.	B, C, D
	Air flow is directed toward the face and the floor.	B, C, D
 (if equipped)	Air flow is coming out of all the vents.	A, B, C, D
	Most of the air flow is directed to the floor, with a small amount of the air being directed to the windshield and side window defrosters.	A, C, D

Symbol	Operation	Direction
	Most of the air flow is directed to the floor and the windshield with a small amount directed to the side window defrosters.	A, C, D
 (if equipped)	All airflow is concentrated toward the defroster.	A

Front windshield defroster [A], [D]



Press the front windshield defroster button (indicator light ON) to turn on the front windshield defroster. If the windshield defogging is set, outside (fresh) mode is automatically selected and the air conditioning turns on according to the detected ambient temperature.

Press the front windshield defroster button once more (indicator light OFF) to turn the function off. Each climate control setting reverts to the setting prior to selecting the front windshield defrost.

Instrument panel vents



- The instrument panel vent air flow can be directed up/down or left/right using the vent adjustment lever.
- The air flow can be closed when the vent adjustment lever is pushed to the  position.

Temperature control



Push up the switch to increase the temperature. Push down to decrease the temperature.

Temperature conversion (°C ↔ °F)

To change the temperature unit from °C to °F or °F to °C:

- Press the **A/C** button for more than 3 seconds, and then within 5 seconds push up the mode selection switch for more than 3 seconds.
- Select **User Settings > Unit > Temperature Unit > °C/°F** in the instrument cluster or **Vehicle > Unit settings > Temperature unit > °C/°F** in the infotainment system.

Driver only



If you press the **DRIVER ONLY** button (indicator light ON), most of the air flow is directed toward the driver's seat.

i Information

Some of the airflow may be directed to other seating position to keep indoor air pleasant while using **DRIVER ONLY**.

When using the front windshield defroster, the air flow on the both sides of windshield will continue to operate regardless of the activation of **DRIVER ONLY**.

Air intake control

Recirculation mode



With the recirculated air selected, air from the passenger compartment is drawn through the climate control system.

Outside (fresh) mode



With the outside (fresh) air selected, air enters the vehicle from outside and is drawn through the climate control system.

i Information

Using the system in the fresh air position is recommended.

Prolonged operation of the heater in the recirculated air position (without air conditioning selected) can cause fogging of the windshield and side windows and the air within the passenger compartment will become stale.

In addition, prolonged use of the air conditioning with the recirculated air position selected will result in excessively dry air in the passenger compartment.

WARNING

To prevent serious injury or death:

- Continued climate control system operation in the recirculated air position may allow humidity to increase inside the vehicle that could fog the windshield and the side windows and obscure visibility.
- Do not sleep in a vehicle with the air conditioning or heating system on.
- Continued climate use of recirculated air may cause drowsiness or sleepiness, and loss of vehicle control. Set the air intake control to the outside (fresh) air position while driving.

Fan speed control



Push up the switch to increase fan speed and airflow. Push down the switch to decrease fan speed and airflow. Pressing the **OFF** button turns off the fan.

i Information

Operating the fan speed when the Start/Stop button is in the ON position may cause the battery to discharge.

Air conditioning



Press the **A/C** button to manually turn on the system on (indicator light ON) and off.

OFF mode

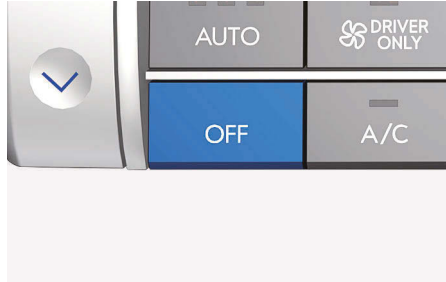

Press the **OFF** button to turn the climate control system off. You can still operate the mode and air intake buttons as long as the Start/Stop button is in the ON position.

System operation

Cooling / Ventilation

1. Set the mode to the position.
2. Set the air intake control to the outside (fresh) air position.
3. Set the temperature control to the desired position.
4. Set the fan speed control to the desired speed.

Heating

1. Set the mode to the position.
2. Set the air intake control to the outside (fresh) air position.
3. Set the temperature control to the desired position.
4. Set the fan speed control to the desired speed.
5. If desired, turn the air conditioning ON with the temperature control button set to heat in order to dehumidify the air before it enters into the cabin.

If the windshield fogs up, set the mode to or position.

Operation Tips

- To keep dust or unpleasant fumes from entering the vehicle through the ventilation system, temporarily set the air intake control to the recirculated air position. Be sure to return the control to the fresh air position when the irritation has passed to keep fresh air in the vehicle. This can help keep the driver alert and comfortable.
- To help prevent interior fog on the windshield, set the air intake control to the fresh air position and the fan speed to the desired position, turn on the air conditioning system, and adjust the temperature control to the desired temperature.

Air conditioning

Your HYUNDAI vehicle air conditioning system is filled with R-134a or R-1234yf refrigerant.

1. Start the vehicle. Press the air conditioning button.
2. Set the mode to the  position.
3. Set the air intake control to outside air or recirculated air position.
4. Adjust the fan speed control and temperature control as desired.

When maximum cooling is desired, set the temperature control to the lowest position, then set the fan speed control to the highest setting.

Air conditioning system operation tips

- If the vehicle has been parked in direct sunlight during hot weather, open the windows for a short time to let the hot air inside the vehicle escape.
- After sufficient cooling has been achieved, switch back from recirculated air position to the fresh outside air position.
- To help reduce moisture inside of the windows on rainy or humid days, decrease the humidity inside the vehicle by operating the air conditioning system with the windows and sunroof closed.
- Use the air conditioning system every month only for a few minutes to ensure maximum system performance.
- If you operate air conditioner excessively, the difference between the temperature of the outside air and that of the windshield may cause the outer surface of the windshield to fog up, causing loss of visibility. In this case, set the mode selection to the  position and fan speed control to the lowest speed.

System maintenance

Cabin air filter

The cabin air filter is installed behind the glove box. It filters the dust or other pollutants that enter the vehicle through the heating and air conditioning system.

We recommend that the cabin air filter be replaced by an authorized HYUNDAI dealer according to the maintenance schedule. If the vehicle is being driven in severe conditions such as dusty or rough roads and/or if transporting pets or occupants smoke inside the vehicle, then more frequent cabin air filter inspections and changes are required.

i Information

- Replace the filter according to the Maintenance Schedule. If the vehicle is being driven in severe conditions such as dusty, rough roads, more frequent climate control air filter inspections and changes are required.
- When the air flow rate suddenly decreases, we recommend that your vehicle be inspected by an authorized HYUNDAI dealer.

Checking the amount of air conditioner refrigerant

If the amount of refrigerant is too low or too high, the performance of the air conditioning is reduced. We recommend that your vehicle be inspected by an authorized HYUNDAI dealer.

NOTICE

The refrigerant system should only be serviced by trained and certified technicians in a well-ventilated area to ensure proper and safe operation.

⚠ WARNING

Vehicles equipped with R-1234yf



To prevent serious injury, have the air conditioning system be serviced by only trained and certified technicians. R-1234yf is flammable and operated at high pressure.

Reclaim all refrigerants with proper equipment. Venting refrigerants directly to the atmosphere is harmful to individuals and environment.

Vehicles equipped with R-134a



To prevent serious injury, have the air conditioning system be serviced by only trained and certified technicians. R-134a is operated at high pressure.

Reclaim all refrigerants with proper equipment. Venting refrigerants directly to the atmosphere is harmful to individuals and environment.

Air conditioning refrigerant label



You can find out which air conditioning refrigerant is applied to your vehicle on the label located inside of the hood.

Type A



Type B



Type C

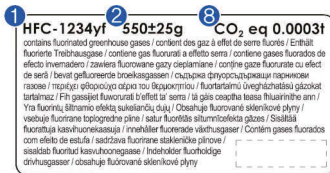



Each symbol and specification on the air conditioning refrigerant label is represented as the following:

- (1) Classification of refrigerant
- (2) Amount of refrigerant
- (3) Classification of compressor lubricant
- (4) Caution
- (5) Flammable refrigerant
- (6) To require registered technician to service air conditioning system
- (7) Service manual
- (8) CO₂ equivalent of refrigerant

Windshield defrosting and defogging

! WARNING

Do not use the defrost level  position during cooling operation in extremely humid weather. The outer surface of the windshield may fog and reduce visibility, causing a collision that results in serious injury or death.

Set the mode selection button to the face level  position and lower the fan speed.

- For maximum defrost performance, set the temperature control switch to the highest temperature setting and the fan speed control to the highest setting.
- If warm air to the floor is desired while defrosting or defogging, select the floor defrost position.
- Before driving, clear all snow and ice from the windshield, rear window, rearview mirrors, and all side windows.
- Clear all snow and ice from the hood and air inlet to improve heater and defroster efficiency and to reduce the probability of fogging up the inside of the windshield.

Automatic climate control system

To defog inside windshield

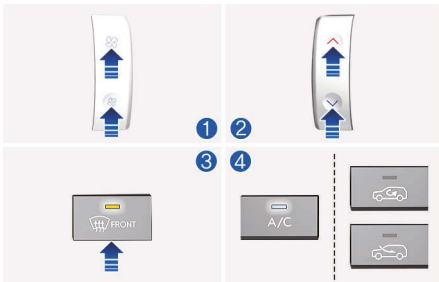

- (1) Select any fan speed. Set the fan speed to the highest position for quick defogging.
- (2) Select the desired temperature.
- (3) Press the defroster button (FRONT)
- (4) The outside (fresh) air is selected automatically. The air conditioning automatically operates. If the air conditioning, outside (fresh) air position are not selected automatically, adjust the corresponding switch.

To defrost outside windshield

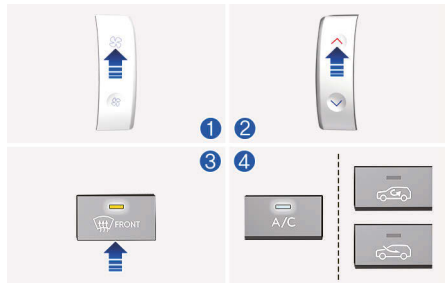

- (1) Set the fan speed to the highest position.
- (2) Set the temperature to the hottest position.
- (3) Press the defroster button (FRONT)
- (4) The air conditioning turns on according to the detected ambient temperature and the outside (fresh) air position is selected automatically.

Defogging logic

if equipped

To reduce the probability of fogging up the inside of the windshield, the air intake or air conditioning are controlled automatically according to certain conditions. To cancel or reset the defogging logic, do the following.

1. Press the Start/Stop button to the ON position.
2. Press the defroster button (FRONT).
3. Press the air intake control button at least 5 times within 3 seconds.

The air intake control button indicator blinks 3 times to indicate that the defogging logic has been disabled. Repeat the steps again to re-enable the defogging logic.

If the battery has been discharged or disconnected, it resets to the defog logic status

Windshield defrosting (Heater)

Rear window defroster

NOTICE

Never use sharp instruments or window cleaners containing abrasives to clean the window to prevent damage to the rear window defroster.

The defroster heats the window to remove frost, fog and thin ice from the interior and exterior of the rear window, while the vehicle is running.

- To activate it, press the rear window defroster button located in the center control panel. The indicator on the rear window defroster button illuminates when the defroster is ON.



- To turn it off, press the rear window defroster button again.

i Information

- If there is heavy accumulation of snow on the rear window, brush it off before operating the rear defroster.
- The rear window defroster automatically turns off after about 20 minutes or when the Start/Stop button is in the OFF position.

Outside rearview mirror defroster

The outside rearview mirror defrosters operate when you turn on the rear window defroster.

Climate control additional features

i Information

The infotainment system may change after software updates. For more information, refer to the manual provided in the infotainment system and the quick reference guide.

Auto defogging system

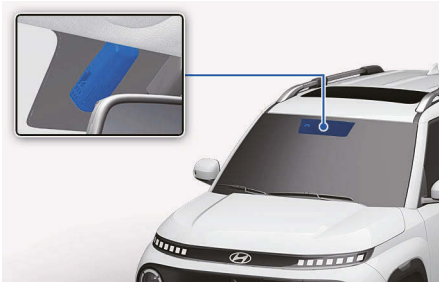

The Auto defogging reduces the likelihood of fogging up the inside of the windshield by automatically sensing the moisture on inside of the windshield.

The Auto defogging system operates when the heater or air conditioning is on.

i Information

The Auto defogging system may not operate normally, when the outside temperature is below -10 °C (14 °F).

When the Auto defogging system operates, the  indicator illuminates.

If high amount of humidity is detected in the vehicle, the Auto defogging system is enabled.

The following steps are performed automatically:

Step 1. Air conditioning turns on and outside (fresh) position is selected.

Step 2. Defrost level is selected.

Step 3. Fan speed is set to the highest level.

If the air conditioning is off or recirculated air is manually selected while Auto defogging system is ON, the Auto defogging system  indicator blinks to signal that manual operation has been canceled.

Turning the Auto defogging system on or off

Climate control system

Press the front windshield defroster button for 3 seconds when the Start/Stop button is in the ON position. When the Auto defogging system is turned off, the  symbol blinks 3 times and appears on the climate control information screen.

When the Auto defogging system is turned on, the  symbol blinks 6 times without a signal.

Infotainment system

Auto defogging system can be turned on and off by pressing the **SETUP** button and then selecting **Vehicle > Climate > Defog/Defrost options > Auto defog** in the infotainment system.

i Information

- Do not select recirculated air while the Auto defogging system is operating.
- When Auto defogging system is operating, fan speed adjustment, temperature adjustment, and air intake control selection are all disabled.

NOTICE

Do not remove the sensor cover located on the top of the windshield glass. Damage may not be covered by your vehicle warranty.

Auto dehumidify

- For Europe

To increase cabin air quality and reduce windshield misting, recirculation mode switches off automatically after about 5 to 30 minutes, depending on the outside temperature, and the air intake changes to the outside (fresh) air position.

- Except Europe

To increase cabin air quality and reduce windshield misting, recirculation mode switches off automatically after about 30 minutes, depending on the outside temperature, and the air intake changes to the outside (fresh) air position.

Turning Auto dehumidify on or off**Climate control system**

To turn the Auto dehumidify feature on or off, select Face level (👤) mode and press the air intake control (🌀) button at least 5 times within 3 seconds. When Auto dehumidify is turned on, the air intake control button indicator blinks 6 times. When turned off, the indicator blinks 3 times.

Infotainment system

Auto dehumidify can be turned on and off by pressing the **SETUP** button and then selecting **Vehicle > Climate > Automatic ventilation > Automatic dehumidify** in the infotainment system.

Recirculating air when washer fluid is used

Recirculation mode automatically activates to reduce the scent of the washer fluid entering the cabin when the windshield washer is used.

When it is shifted to the recirculation mode, the unpleasant scent may flow into the vehicle.

However, in cold weather to prevent the windshield from fogging up, the recirculation mode may not be selected.

Turning Activation on a washer fluid use on or off**Climate control system**

To turn the Activate on washer fluid use feature on or off, select Floor level (👤) mode, Hold the A/C button and press the air intake control (🌀) button 5 times within 3 seconds.

When Activate on washer fluid use is turned on, the air intake control button indicator blinks 6 times. When turned off, the indicator blinks 3 times.

Infotainment system

Activate on washer fluid use can be turned on and off by pressing the **SETUP** button and then selecting **Vehicle > Climate > Internal air circulation > Activate on washer fluid use** in the infotainment system.

Link to climate settings for auto-adjustment

The temperature of the driver's seat warmer, air ventilated seat and heated steering wheel is automatically controlled depending on the inside and outside temperature of the vehicle when the vehicle is ON (READY indicator ON).

To use these features, it must be enabled in the infotainment system.

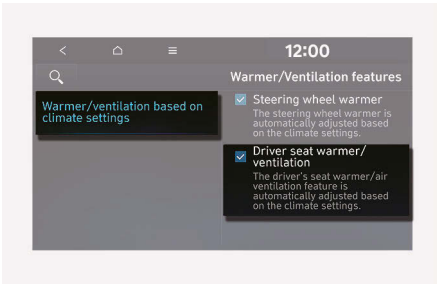

- Press the **SETUP** button, and then select **Vehicle > Seat > Warmer/Ventilation features > Warmer/ventilation based on climate settings**

For more information, refer to the "Seats warmers" section in chapter 3, and "Steering wheel heater" section in chapter 5.

Storage compartment

WARNING

Never store cigarette lighters, propane cylinders, or other flammable/explosive materials in the vehicle. These items may catch fire and/or explode if the vehicle is exposed to hot temperatures for extended periods.

WARNING

ALWAYS keep the storage compartment covers closed securely while driving. Items inside your vehicle are moving as fast as the vehicle. If you have to stop or turn quickly, or if there is a collision, the items may fly out of the compartment and may cause an injury if they strike the driver or a passenger.

NOTICE

To avoid possible theft, do not leave valuables in the storage compartments.

Center console storage



Use it to store small items.

WARNING

Storing sharp objects may lead to serious injuries in the event of a sudden stop or an accident.

Glove box



To open:
Pull the lever [A].

WARNING

ALWAYS close the glove box door after use.

An open glove box door may cause serious injury to a passenger in a collision, even if the passenger is wearing a seat belt.

Cargo tray

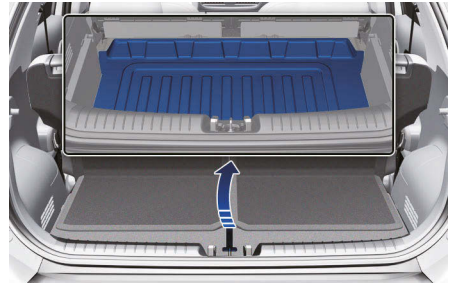

You can place a first aid kit, a reflector triangle (front tray), tools, etc. in the box for easy access.

- Grasp the handle on the top of the cover and lift it.

Passenger seat open tray



You can use this space to store small items etc.

WARNING

Do not put any sharp object in the open tray. It may seriously injure you in the event of a sudden stop or a collision.

Interior features

Cup holder

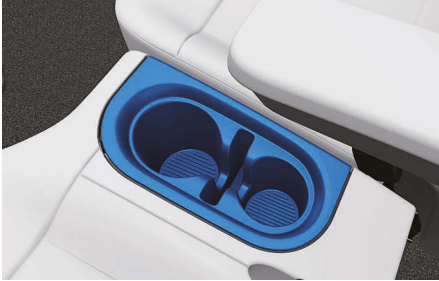

Cups or small beverages cups may be placed in the cup holder

WARNING

- Avoid abrupt starting and braking when the cup holder is used to prevent spilling your drink. If hot liquid spills, you may be burned. Such a burn to the driver may cause loss of vehicle control resulting in a collision.
- Only use soft cups in the cup holders.

NOTICE

- Keep your drinks sealed while driving to prevent spilling. If liquid spills, it may get into the vehicle's electrical/electronic system and damage electrical/electronic parts.
- When cleaning spilled liquids do not use hot air to blow out or dry the cup holder. This may damage the interior.
- Keep cans or bottles out of direct sun light and do not put them in a hot vehicle. Otherwise, they may explode.

Seatback board

 If equipped



Purchase the accessories designed specifically for your vehicle and place it on the board of seatback after folding the front seat seatback.

CAUTION

- Make sure the vehicle is not in motion when folding the seats.
- Avoid any foreign substances entering the air ventilation inlet. This may create noise and cause damage to the air ventilation system.
- Do not forcibly place accessories or exert strong force on the board. This may cause damage to the seatback board.

Sunvisor

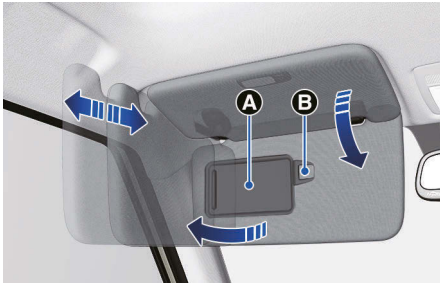

To use the sunvisor, pull it downward.

To use the sunvisor to block the sun from the side window, pull it rearward, release it from the bracket and swing it to the side toward the window.

To use the vanity mirror, pull down the sunvisor and slide the mirror cover [A].

Adjust the sunvisor forward or backward as needed (if equipped). Use the ticket holder [B] to hold tickets.

Close the vanity mirror cover securely and return the sunvisor to its original position after use.

WARNING

Do not block your view or the roadway when using the sunvisor.

NOTICE

The tab [B] adjacent to the vanity mirror on the sunvisor can be used for toll road tickets or self parking tickets. Use caution when inserting tickets into the ticket holder to avoid damage. Refrain from putting several tickets in the ticket holder as this could also damage the retaining tab.

Power outlet



The power outlet is designed to provide power for mobile phones or other devices designed to operate with vehicle electrical systems.

The devices should draw less than 180 W with the vehicle ON.

WARNING

Avoid electrical shocks. Do not place your fingers or foreign objects (pin, etc.) into a power outlet or touch the power outlet with a wet hand.

NOTICE

To prevent damage to the power outlets:

- Use the power outlet only when the vehicle is running and remove the accessory plug after use. Using the accessory plug for an extended period of time with the vehicle off could cause the battery to discharge.
- Only use 12 V electric accessories that are less than 180 W in electric capacity.
- Adjust the air conditioner or heater to the lowest operating level when using the power outlet.
- Close the cover when not used.
- Some electronic devices may cause electronic interference when plugged into a vehicle's power outlet.

- Push the plug in as far as it goes. The plug may overheat and the fuse may open.
- Only connect devices with reverse current protection or the current from the device battery may cause the vehicle's electrical/electronic system to malfunction.

- Do not attempt to use the charging terminal either to turn on an audio or to play media with the infotainment system.
 - Charging may not be possible when using a Type-C to A converter sold by a mobile phone manufacturer or commercially available.
-

USB charger

The USB charger is designed to recharge batteries of small size electronic devices using a USB cable.



The USB charger is designed to recharge batteries of small size electronic devices using a USB cable.

Electronic devices can be charged when the vehicle is running.

i Information

- The battery charging state may be monitored on the electronic device.
- Disconnect the USB cable from the USB port after use.
- A smartphone or a tablet PC may get warmer during the recharging process. It does not indicate any malfunction with the charging system.
- A smartphone or a tablet PC that does not use a USB cable to charge should be charged using its own charger.

NOTICE

- Use the USB charger when the vehicle is running. Using the USB charger for prolonged periods of time with the Start/Stop button in the ON position (vehicle off) may cause the battery to discharge.
 - To prevent damage to the USB charger:
 - Do not insert foreign objects or spill liquid into the outlet. The USB charging terminal may be damaged.
 - Do not use devices with working current exceeding 3,000 mA (3.0 A).
 - When charging an electrical device by using an USB converting adapter (C to A type), use a genuine adapter specified for your vehicle. A commonly used adapter is not equipped with any measures to prevent over current and maintain stability.

Using an unspecified cable may damage the vehicle's USB charger or the connected devices. Contact an authorized HYUNDAI dealer for more information on accessories for HYUNDAI vehicles.
 - The use of non-genuine parts may damage the USB port and infotainment system. Damage cannot be covered by your vehicle warranty.
-

Wireless smartphone charging system

+ if equipped



[A] Indicator light
[B] Charging pad

Charging your smartphone

The wireless smartphone charging system charges only the Qi-enabled smartphones (Φ). Visit your smartphone manufacturer's website to check whether your smartphone supports the Qi technology.

The wireless charging process starts when you put a Qi-enabled smartphone on the wireless charging with the screen facing up.

1. Start the vehicle ('ON') with all the doors are closed.
2. Place the smartphone on the center of the wireless charging pad.
 - The indicator light is orange when the smartphone is charging.
 - The indicator light will turn green when phone charging is complete (Some indicator lights of smartphones will not turn green although the charging is complete).
 - The indicator light will blink orange for max 10 seconds if there is a malfunction in the wireless charging system. In this case, lift the smartphone and re-attempt to charge your phone again.

- Avoid placing other objects, including a smart key on the charging pad. This may interrupt the charging process.

3. The system warns you with a message 'Device in wireless charger' on the cluster display and a warning sound if the smartphone is still on the wireless charging pad after the vehicle is turned OFF and the front door is opened.
 - Some smartphones do not have this warning system. This is due to the particular characteristics of the smartphones and not a malfunction of the wireless charging.
4. You can turn ON or Off the wireless charging function from the Settings menu in the infotainment system screen. Select **Setting > Vehicle > Convenience > Wireless charging system**

! WARNING

Avoid placing magnetic items such as a credit/debit card, bank book, rail ticket, etc. on the wireless charging pad. This may damage saved data.

Cautions to use Wireless Charging Systems

- Place the smartphone on the center of the wireless charging pad. If your smartphone is off to the side, the charging rate may be less and in some cases the smartphone may experience higher heat conduction.
- The wireless charging process may temporarily stop, or its rate will decrease when the surrounding temperature and inside temperature of the wireless charger increases. The wireless charging process restarts, when temperature falls to a certain level.

- The wireless charging process may temporarily stop, when temperature abnormally increases inside the wireless smartphone charging system. The wireless charging process restarts, when temperature falls to a certain level.
- The wireless charging smartphone charging system may not support certain smartphones, which are not verified for the Qi specifications. (℥)
- If the smartphone has a thick cover, wireless charging may not be possible.
- In some cases, the wireless charging may stop temporarily when the smart key is used, either when starting the vehicle or locking/unlocking the doors, etc.

NOTICE

- If your smartphone doesn't have built-in wireless charging, you may need to purchase a separate smartphone accessory.
- When any smartphone without a wireless charging function or a metallic object is placed on the charging pad, a small noise may sound. This small sound is due to the vehicle discerning compatibility of the object placed on the charging pad. It does not affect your vehicle or the smartphone in any way.
- When using wireless charging for a flip type smartphone, fold the phone and place the device's back on the center of the wireless charging pad.
- The update may change the detailed settings of your infotainment system. For detailed settings, refer to the infotainment system web manual.

- When using a smartphone application, such as Android Auto, while charging, the charging process may be delayed or interrupted due to the smartphone overheating. This issue is not related to the wireless charging system but rather caused by the smartphone's self-heating. Therefore, disconnect the smartphone from the charging pad.
- The fan inside the wireless charger runs to dissipate heat during charging and this may create noise.

Vehicle to load (V2L)



V2L(Vehicle to Load) is installed under the front center console storage. V2L is a convenient feature which provides enough electricity to use diverse household electrical appliances in the vehicle.

For more information, refer to the "Using V2L function" section in chapter 1.

Coat hook

Rear



This hook is not designed to hold large or heavy items.

WARNING

Only hang soft clothing without heavy, sharp or breakable objects in the clothes pockets. In a collision or when the curtain airbag is inflated, the objects could move and cause serious injury.

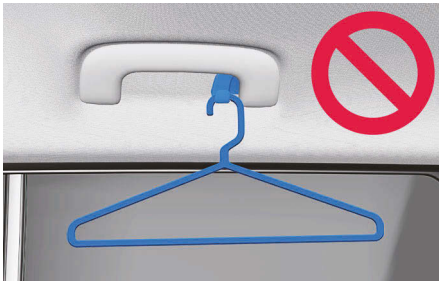

Shopping bag hook

Center Fascia



Door armrest (passenger seat)



Hooks are located in the passenger seat center fascia and door armrest [A].

- Pull down the hook on door armrest to use it. The hook will return to its original position once you release it.

CAUTION

The hook is not designed to hold heavy objects. This may damage the hook.

WARNING

Do not hang any hard, sharp or fragile objects on a shopping bag hook. This may damage the interior of your vehicle once the object moves while the vehicle is in motion. This can also result in serious injury or death.

Upper garnish



You may replace other specifications with a detachable upper garnish.

i Information

Refer to the separately provided manual for replacement.

Van package

if equipped

Luggage net behind 1st row



Use the Luggage net to separate the cargo area and passenger seats to prevent stored items from falling into the passenger seats when a vehicle brakes suddenly or is involved in a collision.

1. Connect the strap to both handles located in the center.
2. Remove it from handles when not in use.

i Information

For more information on the installation, refer to the manual provided.

! WARNING

- After installing the net, avoid boarding passengers in the rear seat or in the cargo area.
- Avoid loading an item of which height is higher than that of the net. This may lead to an item falling down, causing serious injury to passengers.
- Although you have installed the net, do not store too heavy or sharp items to prevent any accidents caused by a sudden stop or collision.
- Do not exert excessive force or hang heavy items on the net. This may damage the net.

Luggage box



You can store various tools and small items in the luggage box.

Pull the handle upward to use it.

Luggage mat



Use the Luggage Mat to prevent any damage or movement of items you are carrying.

i Information

Depending on the surrounding environment, you may find the net wrinkled.

Luggage protector



Use the Luggage Protector to prevent any damage to your vehicle when you load or unload items in the cargo area.

Floor mat anchor(s)

ALWAYS use the floor mat anchors to attach the front floor mats to the vehicle. The anchors on the front floor carpet keep the floor mats from sliding forward.

! WARNING

To prevent serious injury or death from a floor mat interfering with the brake or accelerator pedals:

- Remove any protective film on the carpet before installing a floor mat.
- Check floor mats are securely attached to the vehicle's floor mat anchors before driving.
- Do not use ANY floor mat that cannot be firmly attached to the vehicle's floor mat anchors.
- Do not stack floor mats on top of one another (for example, all-weather rubber mat on top of a carpeted floor mat). Only a single floor mat must be installed in each position.

! WARNING

To avoid any interference with pedal operation, HYUNDAI recommends that the HYUNDAI floor mat designed for use in your vehicle be installed.

Cargo area cover

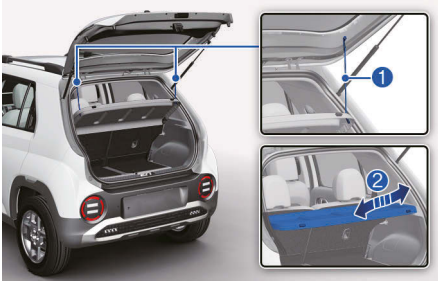

Use the cargo area cover to hide items stored in the cargo area. You can also place lightweight items on top.

- If the cargo area cover is connected to the tailgate, the cover lifts with the tailgate when opening the tailgate.
- If you do not want the cargo area cover to lift with the tailgate, disconnect the strap (1) from the strap holder of the tailgate.

Removing cargo area cover

To remove the cargo area cover:

1. Disconnect the strap (1) from the strap holder of the tailgate.
2. Lift the cover diagonally and pull it out (2).

To reinstall, follow the reverse order.

CAUTION

- When the cargo area cover is removed, you can secure the cover to the rear seatback not to distract you while driving.
- Since the cargo area cover also lifts when opening the tailgate, move the items placed on top of the cover to a safe place so they do not fall.
- Do not put excessive pressure or weight on the cargo area cover. The cargo area cover may be damaged.

Cargo security screen

 If equipped

Use the cargo security screen to cover items stored in the cargo area.

- If the cargo area cover is connected to the tailgate, the cover lifts with the tailgate when opening the tailgate.
- If you do not want the cargo area cover to lift with the tailgate, disconnect the strap holder from the rear headrest.

Removing and store cargo c cover

To remove the cargo area cover:

1. Disconnect the strap holder (1) from the rear headrest.



2. Lift the cover diagonally and pull it out (2).



3. When not in use, store the screen holder on the covering shelf or screen by securing it to the bracket on the back.

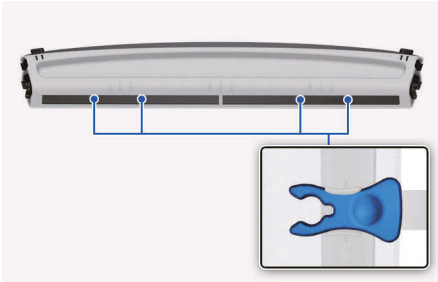

4. To mount, lay the covering shelf down and slide it onto the bottom fixing [A], taking care not to catch on any other parts.

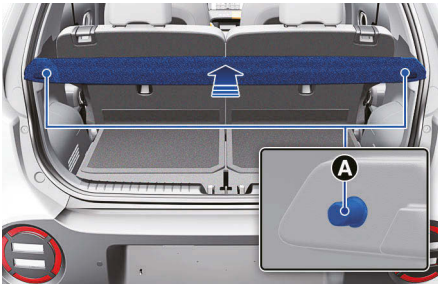

⚠ CAUTION

- When the cargo area cover is removed, you can secure the cover to the rear seatback not to distract you while driving.
- Since the cargo area cover also lifts when opening the tailgate, move the items placed on top of the cover to a safe place so they do not fall.
- Do not put excessive pressure or weight on the cargo area cover. The cargo area cover may be damaged.

Exterior features

Roof side rails

+ if equipped



Your vehicle may come equipped with roof side rails. If your vehicle is equipped with roof rack rails, you can add roof rack crossbars as an accessory (not shown).

i Information

- If the vehicle is equipped with a sunroof, do not position the cargo onto the roof side rails in such a way that it may interfere with sunroof operation.
- Always take precautions to make sure the cargo does not damage the roof.
- When carrying large objects on the roof side rails, make sure they do not exceed the overall roof length or width.
- When carrying cargo on the roof side rails, take necessary precautions to make sure the cargo does not damage the roof of the vehicle.

When carrying large objects on the roof side rails, make sure they do not exceed the overall roof length or width.

WARNING

- Loading cargo or luggage in excess of the specified weight limit on the roof side rails may damage your vehicle.

ROOF SIDE RAILS	75 kg (165 lbs.) EVENLY DISTRIBUTED
-----------------	--

- Avoid sudden starts, braking, sharp turns, abrupt maneuvers, or high speeds that may result in loss of vehicle control or rollover resulting in a collision. The vehicle center of gravity is higher when items are loaded onto the roof side rails.
- Always drive slowly and turn corners carefully when carrying items on the roof side rails. Severe wind updrafts caused by passing vehicles or natural causes, can cause sudden upward pressure on items loaded on the roof side rails. This is especially true when carrying large, flat items such as wood panels or mattresses. This may cause the items to fall off the roof side rails and cause damage to your vehicle or others around you.
- To prevent damage or loss of cargo while driving, check frequently before or while driving to make sure the items on the roof side rails are securely fastened.

Roof basket

 If equipped



Use the roof basket to load cargo on the roof.

It is an auxiliary device to load cargo. Be sure to position cargo properly while considering the vehicle condition and driving safety.

Information

Driving at high speed can create noise.

Information

- Always take precautions to make sure the cargo does not damage the roof.
- When carrying large objects on the roof basket, make sure they do not exceed the overall roof length or width.
- When carrying cargo on the roof basket, take necessary precautions to make sure the cargo does not damage the roof of the vehicle.

When carrying large objects on the roof basket, make sure they do not exceed the overall roof length or width.

WARNING

- If your vehicle is equipped with a roof basket and enters an automatic car wash, this can damage your vehicle and the automatic car wash.
- Loading cargo or luggage in excess of the specified weight limit on the roof basket may damage your vehicle.

Roof basket	75 kg (165 lbs.) EVENLY DISTRIBUTED
-------------	--

- Avoid sudden starts, braking, sharp turns, abrupt maneuvers, or high speeds that may result in loss of vehicle control or rollover resulting in a collision. The vehicle center of gravity is higher when items are loaded onto the roof basket.
- Always drive slowly and turn corners carefully when carrying items on the roof basket. Severe wind updrafts caused by passing vehicles or natural causes, can cause sudden upward pressure on items loaded on the roof basket. This is especially true when carrying large, flat items such as wood panels or mattresses. This may cause the items to fall off the roof basket and cause damage to your vehicle or others around you.
- To prevent damage or loss of cargo while driving, check frequently before or while driving to make sure the items on the roof basket are securely fastened.

Infotainment system

NOTICE

- Do not install an aftermarket HID headlight. Your vehicle's audio and electronic devices may not function properly.
- Prevent chemicals such as perfume, cosmetic oil, sun cream, hand cleaner, and air freshener from contacting the interior parts because they may cause damage or discoloration.

USB Port



- You can use a USB cable to connect audio devices to the vehicle USB port.
- After connecting a media storage device such as a MP3 or USB to the USB port, you can listen to music through the vehicle's speakers or play it on the infotainment system.
- Small electronic devices can be charged.

i Information

- Some devices may not be charged through USB port.
- When using a portable audio device connected to the power outlet, noise may occur during playback. If this happens, disconnect the USB cable and use the portable audio device's power source.

NOTICE

- When connecting a Type-A USB or a memory device to a vehicle, use a genuine converting adapter (C to A type) specified for your vehicle. A commonly used adapter is not equipped with any measures to reduce noise, prevent overcurrent and maintain stability. Connecting an unspecified cable may damage the vehicle's USB port or the connected devices. We recommend that you contact an authorized HYUNDAI dealer for more information on accessories for HYUNDAI vehicles.
- The use of non-genuine parts may damage the USB port and infotainment system. Damage cannot be covered by your vehicle warranty.

Antenna



The shark fin antenna receives transmitted data (for example, AM/FM, SXM).

Steering wheel remote controls

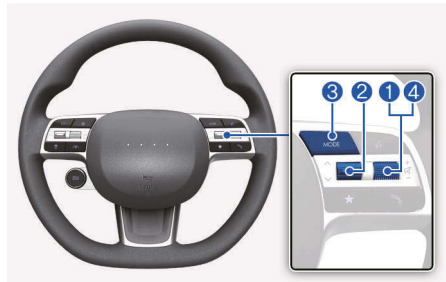

NOTICE

Do not operate multiple audio remote control buttons simultaneously.

VOLUME (+ / -) (1)

Push the lever up or down to adjust the volume.

SEEK/PRESET (^ / v) (2)

If the SEEK/PRESET switch is pushed up or down and held for 0.8 seconds or more, it functions in the following modes:

- RADIO mode
It functions as the AUTO SEEK select button. It seeks until you release the button.
- MEDIA mode
It functions as the FF/RW button.

If the SEEK/PRESET switch is pushed up or down, it functions in the following modes:

- RADIO mode
It functions as the PRESET STATION UP/DOWN button.
- MEDIA mode
It functions as the TRACK UP/DOWN button.

MODE (3)

Press the MODE button to toggle through Radio mode.

MUTE (🔇) (4)

Press the VOLUME lever to mute or activate the sound.

Infotainment system

For more information, refer to the separately supplied infotainment system manual.

Voice recognition

For more information, refer to the separately supplied infotainment system manual.

Bluetooth® wireless technology

- (1) Call/Answer/Call end button
- (2) Microphone

For more information, refer to the separately supplied infotainment system manual.

⚠ CAUTION

To prevent driver distractions, minimize your use of these features while driving. Distraction may cause a collision, resulting in serious injury or death.

6. Driving your vehicle

Before driving	6-3
Before entering the vehicle.....	6-3
Before starting	6-3
Start/Stop button	6-4
Start/Stop button positions.....	6-5
Starting the vehicle.....	6-6
Turning off the vehicle.....	6-7
Remote start.....	6-8
Reduction gear	6-8
Reduction gear operation	6-8
Cluster display messages	6-12
Good driving practices	6-13
Regenerative braking system	6-14
Using regenerative braking system.....	6-14
Regenerative braking system limitations.....	6-15
One Pedal Driving	6-16
Using i-PEDAL	6-17
Smart regeneration system	6-18
Smart regeneration system on/off	6-18
Smart regeneration system operating condition	6-19
Smart regeneration level settings.....	6-19
Pausing smart regeneration system.....	6-20
Front sensors (Front radar).....	6-20
System warning due to sensor problems.....	6-20
Smart regeneration system precautions.....	6-21
Braking system	6-23
Power-assist brakes.....	6-23
Disc brakes wear indicator	6-24
Electronic Parking Brake (EPB)	6-24
Auto Hold.....	6-27
Brake Disc Cleaning.....	6-29
Anti-Lock Brake System (ABS).....	6-30
Electronic Stability Control (ESC)	6-31
Vehicle Stability Management (VSM).....	6-33
Hill-Start Assist Control (HAC)	6-34
Emergency Stop Signal (ESS).....	6-35

Multi-Collision Brake (MCB)	6-35
Brake Assistant System (BAS)	6-36
Good braking practices	6-36
Drive mode integrated control system	6-37
Drive mode	6-37
Drive mode characteristic	6-38
Active air flap	6-39
Malfunction	6-39
Special driving conditions	6-40
Hazardous driving conditions	6-40
Rocking the vehicle	6-40
Smooth cornering	6-41
Driving at night	6-41
Driving in the rain	6-41
Driving in flooded areas	6-41
Highway driving	6-42
Winter driving	6-43
Snow or icy conditions	6-43
Winter precautions	6-44
Trailer towing	6-45
Vehicle weight	6-46
Overloading	6-46

Before driving

Before entering the vehicle

- Be sure all windows, outside rearview mirror(s), and outside lights are clean and unobstructed.
- Remove frost, snow, or ice.
- Visually check the tires for uneven wear and damage.
- Check under the vehicle for any sign of leaks.
- Be sure there are no obstacles behind you if you intend to back up.

Before starting

- Make sure the hood, the tailgate, and the doors are securely closed and locked.
- Adjust the position of the seat and steering wheel.
- Adjust the inside and outside rearview mirrors.
- Verify all the lights work.
- Fasten your seat belt. Check that all passengers have fastened their seat belts.
- Check the gauges and indicators in the instrument panel and the messages on the instrument cluster when the vehicle is in the ON position.
- Check that any items you are carrying are stored properly or fastened down securely.

WARNING

To reduce the risk of SERIOUS INJURY or DEATH, take the following precautions:

- ALWAYS wear your seat belt. All passengers must be properly belted whenever the vehicle is moving. For more information, refer to the "Seat belts" section in chapter 3.
- Always drive defensively. Assume other drivers or pedestrians may be careless and make mistakes.
- Stay focused on the task of driving. Driver distraction can cause accidents.
- Leave plenty of space between you and the vehicle in front of you.

WARNING

NEVER drink or take drugs and drive.

Drinking or taking drugs and driving is dangerous and may result in an accident and SERIOUS INJURY or DEATH.

Drunk driving is the number one contributor to the highway death toll each year. Even a small amount of alcohol will affect your reflexes, perceptions and judgment. Just one drink can reduce your ability to respond to changing conditions and emergencies and your reaction time gets worse with each additional drink.

Driving while under the influence of drugs is as dangerous or more dangerous than driving under the influence of alcohol.

You are much more likely to have a serious accident if you drink or take drugs and drive. If you are drinking or taking drugs, do not drive. Do not ride with a driver who has been drinking or taking drugs. Choose a designated driver or call a taxi.

Start/Stop button



Whenever the front door is opened, the Start/Stop button illuminates and goes off for a few seconds after the door is closed.

WARNING

To turn the vehicle off in an emergency: Press and hold the Start/Stop button for more than 2 seconds OR Rapidly press and release the Start/Stop button 3 times (within 3 seconds).

If the vehicle is still moving, you can restart the vehicle without depressing the brake pedal by pressing the Start/Stop button with the gear in the N (Neutral) position.

WARNING

- NEVER press the Start/Stop button while the vehicle is in motion except in an emergency. This results in the vehicle turning off and loss of power assist for the steering and brake systems. This may lead to loss of directional control and braking function, which could cause an accident.
- Before leaving the driver's seat, always make sure the gear is in the P (Park) position, set the parking brake, press the Start/Stop button to the OFF position, and take the Smart Key with you. Unexpected vehicle movement may occur if these precautions are not followed.
- NEVER reach through the steering wheel for the Start/Stop button or any other control while the vehicle is in motion. The presence of your hand or arm in this area may cause a loss of vehicle control resulting in an accident.

Start/Stop button positions

Button Position	Action	Notes
OFF	To turn off the vehicle, press the Start/Stop button with the vehicle in P (Park). If the Start/Stop button is pressed with the vehicle in D (Drive), R (Reverse) or N (Neutral), the gear automatically shifts to P (Park).	If the steering wheel is not locked properly when you open the driver's door, the warning chime will sound.
ACC	Press the Start/Stop button when the button is in the OFF position without depressing the brake pedal. Some of the electrical accessories are usable.	If you leave the Start/Stop button in the ACC position for more than one hour, the battery power turns off automatically to prevent the battery from discharging.
ON	Press the Start/Stop button while it is in the ACC position without depressing the brake pedal. The warning lights can be checked before the vehicle is started.	Do not leave the Start/Stop button in the ON position when the vehicle is not running to prevent the battery from discharging.
START	To start the vehicle, depress the brake pedal and press the Start/ Stop button with the gear shifted to the P (Park) position.	If you press the Start/Stop button without depressing the brake pedal, the vehicle does not start and the Start/Stop button changes as follows: OFF > ACC > ON > OFF or ACC

i Information

To prevent vehicle battery discharge, the Start/Stop button changes to the OFF position when the Start/Stop button is in the ACC or ON position with the gear in P (Park) for a certain period of time. When the function operates, the tail lights turns off. To use the tail lights again, turn the headlight switch located on the steering column to the OFF and ON position again.

Starting the vehicle

WARNING

- Always wear appropriate shoes when operating your vehicle. Unsuitable shoes, such as high heels, ski boots, sandals, flipflops, etc., may interfere with your ability to use the brake and accelerator pedals.
- Do not start the vehicle with the accelerator pedal depressed.
The vehicle can move which can lead to an accident.

Information

- The vehicle starts by pressing the Start/Stop button, only when the smart key is in the vehicle.
- Even if the smart key is in the vehicle, and when it is far away from the driver, the vehicle may not start.
- When the Start/Stop button is in the ACC or ON position, if any door is open, the system checks for the smart key. When the smart key is not in the vehicle, the  indicator blinks and the warning message "Key not in vehicle" appears. When all doors are closed, the chime also sounds for a few seconds. Keep the smart key in the vehicle when in the ACC position or if the vehicle is in the ready mode (READY indicator ON).

NOTICE

- The vehicle enters the ready mode (READY indicator on) if you get in the vehicle with a smart key while scheduled climate or remote climate control is operating.
- The vehicle also enters the ready mode if you get in the vehicle and place the NFC digital key on the vehicle authentication pad (wireless charging pad), and then close the door or depress the brake pedal.
- If a smart key or digital key (if equipped) is not detected in the vehicle after the door is closed or the brake pedal is depressed, a warning message appears.
- When the vehicle is in the ready mode, be careful as the vehicle may move when shifting the gear from P (Park) to another gear position.

Starting the vehicle

1. Always carry the smart key with you.
2. Make sure the parking brake is applied.
3. Make sure the gear is in P (Park).
4. Depress the brake pedal.
5. Press the Start/Stop button. If the vehicle starts, the READY indicator comes on.

Information

- Always start the vehicle with your foot on the brake pedal. Do not depress the accelerator while starting the vehicle. Do not race the motor while warming it up.
- If ambient temperature is low, the  indicator may remain illuminated longer than the normal amount of time.

NOTICE

To prevent damage to the vehicle:

- If the READY indicator turns off while you are moving, do not attempt to shift the gear to the P (Park) position.

If traffic and road conditions permit, you may put the gear in N (Neutral) while the vehicle is still moving and press the Start/Stop button in an attempt to restart the vehicle.

- Do not push or tow your vehicle to start the vehicle.

NOTICE

To prevent damage to the vehicle:

Do not press the Start/Stop button for more than 10 seconds except when the stop light fuse is blown.

When the stop light fuse is blown, you cannot normally start the vehicle. Replace the fuse with a new one. If you are not able to replace the fuse, you can start the vehicle by pressing and holding the Start/Stop button for 10 seconds with the Start/Stop button in the ACC position.

Pressing the brake pedal many times while READY indicator light is off will increase the possibility of discharging the 12 V battery.

For your safety always depress the brake pedal before starting the vehicle.

i Information

Virtual Engine Sound System (V ESS)

V ESS generates virtual engine sound to make pedestrians to aware. V ESS operates when the vehicle can be driven. When the gear is in P (Park), V ESS does not work.

! CAUTION

- Because the vehicle does not make the engine sound, pay attention to the surrounding environment and drive carefully.
- After parking or waiting for a traffic light, check around (children, obstacle, etc.) before departure.
- When reversing, check directly behind you before driving. Pedestrians may not be able to recognize vehicle sounds.

Emergency starting

If the smart key battery is weak or the smart key does not work correctly, you can start the vehicle by pressing the Start/Stop button with the smart key in the direction of the picture above.

Turning off the vehicle

1. Stop the vehicle and depress the brake pedal fully.
2. Shift to P (Park).
3. Press the Start/Stop button to the OFF position and apply the parking brake.
4. Make sure the READY indicator is off in the instrument cluster.

! CAUTION

If the READY indicator on the instrument cluster is still on, the vehicle is not turned off and can move when the gear is in any position except P (Park).

Remote start

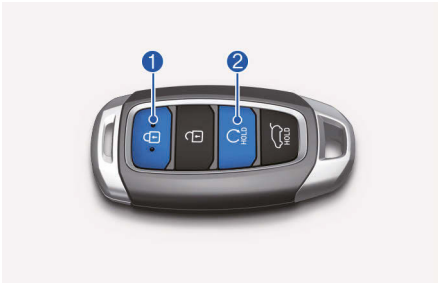

You can start the vehicle using the Remote Start button of the smart key.

To start the vehicle remotely:

1. Press the door lock (1) button within 10 m (32 ft.) from the vehicle.
2. Press and hold the remote start (2) button within 4 seconds.
3. To turn off the remote start function, press the remote start (2) button once.
 - The remote start (2) button may not operate if the smart key is not within 10 m (32 ft).
 - The vehicle may not remotely start if the hood or tailgate is opened.
 - The vehicle must be in P (Park) for the remote start function to start.
 - The vehicle displays "**Smart Key must be present to keep the vehicle running**" if you get on the vehicle without a registered smart key.
 - The vehicle turns off if you do not get in the vehicle within 10 minutes after remotely starting the vehicle.

Reduction gear



- [A] Rotary gear shift dial
- [B] P button

Reduction gear operation

To change the gear, depress the brake pedal and rotate the rotary gear shift dial.

WARNING

To reduce the risk of serious injury or death:

- Always check the surrounding areas near your vehicle for people, especially children, before shifting a vehicle into D (Drive) or R (Reverse).
- Before leaving the driver's seat, always make sure the vehicle is shifted to the P (Park) position, then apply the parking brake, then press the Start/Stop button to the OFF position. Unexpected and sudden vehicle movement can occur if these precautions are not followed.

Rotary shifter/Rotary gear shift dial

P (Park)



Always come to a complete stop before shifting into P (Park).

To shift the gear to P (Park), press the P button while depressing the brake pedal.

If you turn the vehicle off in R (Reverse), N (Neutral) or D (Drive), the gear automatically shift to P (Park).

WARNING

- Shifting into P (Park) while the vehicle is moving may cause you to lose control of the vehicle.
- When parking on an incline, shift the gear to P (Park), apply the parking brake, and turn the wheels toward the curb to prevent the vehicle from rolling downhill.
- Do not use the P (Park) position instead of the parking brake.

Information

For vehicles equipped with the Electronic Parking Brake (EPB), EPB applies automatically when the gear is shifted to P (Park).

R (Reverse)



Use this position to drive the vehicle backward.

To shift the gear to R (Reverse), rotate the rotary gear shift dial to R (Reverse) while depressing the brake pedal.

However, if the vehicle is moving, the gear may not automatically shift to P (Park) to prevent reduction gear damage. The direction of the rotary gear shift dial is the same as that of the wheel.

NOTICE

- When the vehicle is stopped in R (Reverse) or D (Drive), if the driver's door is opened, the gear shifts to P (Park) automatically.
If the vehicle is moving in R (Reverse) or D (Drive) and the driver's door is opened and the driver's seat belt is unfastened, the gear may not shift to P (Park) automatically to prevent reduction gear damage.
- Always come to a complete stop before shifting into or out of R (Reverse) to prevent damaging the reduction gear.

N (Neutral)

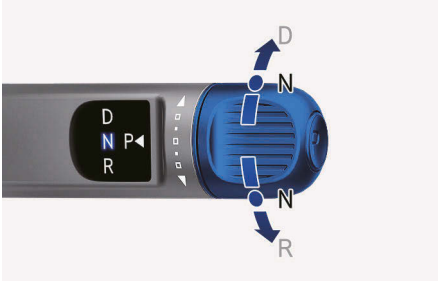

To shift the gear to N (Neutral), rotate the rotary gear shift dial to N (Neutral) while depressing the brake pedal.

Always depress the brake pedal when you are shifting from N (Neutral) to another gear.

If you turn the vehicle off in N (Neutral), the gear automatically shifts to P (Park).

However, if you need to stay in N (Neutral) with the vehicle off, refer to the "To stay in N (Neutral) when vehicle is OFF" section in the following description.

To rotate the rotary gear shift dial to N (Neutral), rotate the rotary gear shift dial once clockwise or counterclockwise.

If the current gear position is in D (Drive), rotate the rotary gear shift dial counterclockwise. When the gear position is in R (Reverse), rotate the rotary gear shift dial clockwise.

D (Drive)



To shift the gear to D (Drive), rotate the rotary gear shift dial to D (Drive) while depressing the brake pedal.

The reduction gear automatically activates the regenerative braking system according to the road conditions.

NOTICE

- When the vehicle is stopped in R (Reverse) or D (Drive), if the driver's door is opened, the gear shifts to P (Park) automatically.
If the vehicle is moving in R (Reverse) or D (Drive) and the driver's door is opened and the driver's seat belt is unfastened, the gear may not shift to P (Park) automatically to prevent reduction gear damage.
- Always come to a complete stop before shifting into D (Drive) to prevent reduction gear damage.

CAUTION

When you start after stopping on a steep incline, even if the gear is in D (Drive), if you do not depress the accelerator or brake pedal, the vehicle may roll backwards, which can cause an accident.

To stay in N (Neutral) when vehicle is OFF

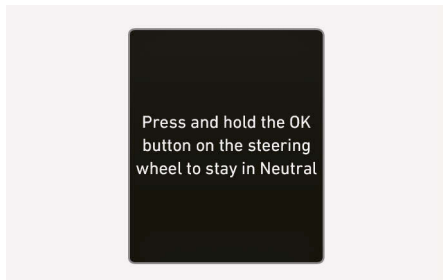

If you want to stay in N (Neutral) after the vehicle is in the ACC state, do the following.

1. Turn off Auto Hold and release Electronic Parking Brake when the vehicle is running.
2. Rotate the rotary gear shift dial to N (neutral) while depressing the brake pedal.
3. When you take your foot off the brake pedal, the message "**Press and hold the OK button on the steering wheel to stay in Neutral**" appears on the cluster display.
4. Press and hold the **OK** button on the steering wheel for more than 1 second.
5. When the message "**Vehicle will stay in (N). Change gear to cancel.**" appears on the cluster display, press the Start/Stop button while depressing the brake pedal.

If you open the driver's door within 3 minutes, the gear shifts to P (Park) and the Start/Stop button changes to the OFF position.

NOTICE

- With the gear in N (Neutral), the Start/Stop button is in the ACC position. Note that the doors cannot be locked in the ACC position or the 12 V battery may discharge if left in the ACC position for a long time.
- Before entering an automatic car wash, release the Electronic Parking Brake (EPB) manually. If EPB is applied, it may damage the vehicle or automatic car wash.

i Information

When the Electronic Parking Brake (EPB) is applied, press the EPB switch while depressing the brake pedal. The Electronic Parking Brake (EPB) must be released manually because EPB does not release automatically even though the gear is shifted to N (Neutral).

Automatic gear shift to P (Park)

The gear is shifted to P (Park) automatically for safety reasons under the following conditions:

- When the vehicle is turned off with the gear in R (Reverse), D (Drive) or N (Neutral).
- When the driver's door is open with the vehicle running, the gear in R (Reverse), D (Drive) or N (Neutral), and the vehicle at a standstill.
- When the driver's door is open with the gear in N (Neutral) and the vehicle is on.

In situations the gear must be in P (Park), always check if the gear is shifted to P (Park) by checking the instrument cluster.

Shift-lock system

For your safety, your vehicle has a shift-lock system which prevents shifting the gear from P (Park) or N (Neutral) into R (Reverse) or D (Drive) unless the brake pedal is depressed.

To shift from P (Park) or N (Neutral) into R (Reverse) or D (Drive), from R (Reverse) into D (Drive) or from D (Drive) into R (Reverse):

1. Depress and hold the brake pedal.
2. Start the vehicle.
3. Depress the brake pedal and shift the gear in R (Reverse) or D (Drive).

i Information

The gear cannot be shifted while the charging cable is connected.

When the battery (12 V) is discharged

You cannot shift the gears when the battery is discharged.

Jump start your vehicle (refer to the "Jump starting (12 V battery)" section in chapter 8 or we recommend that you contact an authorized HYUNDAI dealer.

Parking

Always come to a complete stop and continue to depress the brake pedal. Shift the gear to P (Park), apply the EPB, and press the Start/Stop button to the OFF position. Take the key with you when leaving the vehicle.

Cluster display messages

Press brake pedal to change gear

This message is displayed when the brake pedal is not depressed while shifting the gear.

Depress the brake pedal and then shift the gear.

Shift to P after stopping

This message is displayed when the gear is shifted to P (Park) while the vehicle is moving.

Stop the vehicle before shifting to P (Park).

This gear is already selected

This message is displayed when the currently selected shift gear is selected again.

This message is displayed when the shift gear does not properly operate in the P (Park) position.

We recommend that your vehicle be inspected by an authorized HYUNDAI dealer.

Check P button

This message is displayed when there is a problem with the P (Park) button.

If this message is displayed when the button is not pressed, we recommend that your vehicle be inspected by an authorized HYUNDAI dealer.

Shifting system error

This message is displayed when there is a malfunction with the rotary gear shift dial.

We recommend that your vehicle be inspected by an authorized HYUNDAI dealer.

Check rotary gear shift dial

This message is displayed when there is a malfunction with the rotary gear shift dial.

We recommend that your vehicle be inspected by an authorized HYUNDAI dealer.

Rotary gear shift dial stuck

This message is displayed when the rotary gear shift dial does not return back to its normal position after rotating it.

We recommend that your vehicle be inspected by an authorized HYUNDAI dealer.

PARK button error! Engage parking brake when parking vehicle

This message is displayed when the P (Park) button does not operate properly.

We recommend that your vehicle be inspected by an authorized HYUNDAI dealer.

Good driving practices

- Never shift the gear from P (Park) or N (Neutral) to any other position with the accelerator pedal depressed.
- Never shift the gear into P (Park) when the vehicle is moving.

Be sure the vehicle is completely stopped before you attempt to shift into R (Reverse) or D (Drive).

- Do not shift the gear to N (Neutral) when driving. If the gear is shifted to N (Neutral) while driving. Doing so may increase the risk of an accident.

Also, shift the gear back to D (Drive) while the vehicle is moving may severely damage the reduction gear.

- When driving uphill or downhill, always shift to D (Drive) for driving forward or shift to R (Reverse) for driving rearwards. After selecting D (Drive) or R (Reverse), check the gear position indicated on the instrument cluster before driving. If the vehicle moves in the opposite direction of the selected gear, the vehicle may turn off and a serious accident might occur due to degraded brake performance.
- Do not drive with your foot resting on the brake pedal. Even light, but consistent pedal pressure can result in the brakes overheating, brake wear and possibly even brake failure.
- Always apply the parking brake when leaving the vehicle. Do not depend on placing the shift gear in P (Park) to keep the vehicle from moving.
- Exercise extreme caution when driving on a slippery surface. Be especially careful when braking, accelerating or shifting gears. On a slippery surface, an abrupt change in vehicle speed can cause the drive wheels to lose traction and may cause loss of vehicle control resulting in an accident.

- Optimum vehicle performance and economy is obtained by smoothly depressing and releasing the accelerator.

WARNING

To reduce the risk of **SERIOUS INJURY** or **DEATH**:

- **ALWAYS** wear your seat belt. In a collision, an unbelted occupant is significantly more likely to be seriously injured or killed than a properly belted occupant.
- Avoid high speeds when cornering or turning.
- Do not make quick steering wheel movements, such as sharp lane changes or fast, sharp turns.
- The risk of rollover is greatly increased if you lose control of your vehicle at highway speeds.
- Loss of control often occurs if two or more wheels drop off the roadway and the driver over steers to reenter the roadway.
- In the event your vehicle leaves the roadway, do not steer sharply. Instead, slow down before pulling back into the travel lanes.
- **HYUNDAI** Vehicle recommends you to follow all posted speed limits.

Regenerative braking system

Regenerative braking system operates the paddle shifter to control the regenerative braking intensity of the vehicle. It improves the energy efficiency of the vehicle and helps the driver to have a better driving experience.

Information

The regenerative braking system uses the electric motor to engage the brake. The electric motor converts the kinetic energy generated from decelerating the vehicle to electricity and charges the high voltage battery.

Using regenerative braking system

Operating paddle shifter

Operate the paddle shifter as shown below to use the regenerative braking system.



(1) Regenerative braking increase lever (+)

(2) Regenerative brake decrease lever (-)

- Pull the left paddle shift (+) once to raise the regenerative braking intensity level by 1. It increases decelerating intensity.

- Pull the right paddle shift (-D) once to lower the regenerative braking intensity level by 1. It decreases decelerating intensity.
- Pull and hold the left paddle shift (+D) for over 1 seconds to keep raising the regenerative braking intensity level. Keeping hold of the paddle shift brings the vehicle to stop. (For more information, refer to the "One Pedal Driving" section in this chapter.)
- (While the smart regeneration system is turned on) Pull and hold the right paddle (-D) shift for over 1 second to turn off the smart regeneration system. (For more information, refer to the "Smart regeneration system" section in this chapter.)

Checking the amount of regenerative braking



The selected regenerative braking level is displayed on the instrument cluster. When the vehicle is turned off and on again after the regenerative braking level is lowered to 0, the braking level changes to 1.

Regenerative braking system limitations

Regenerative braking intensity cannot be changed using the paddle shifter in the following situations:

- When the both paddle shifters are pulled at the same time.
- When the vehicle is decelerating by depressing the brake pedal.
- When Smart Cruise Control is activated.
- When regenerative braking is continuously operated with the battery fully charged.
- When the SNOW mode is activated.

Initial setting of the regenerative braking level and adjustable range vary according to the selected Drive mode.

Drive mode	Adjustable Range
SNOW	0 to 1
ECO	0 to 4
NORMAL	0 to 4
SPORT	0 to 4

For more information, refer to the "Drive mode integrated control system" section in this chapter.

One Pedal Driving

One pedal driving operates the paddle shifter while coasting to control the intensity of regenerative braking. It assists the driver to stop the vehicle without depressing the brake pedal.

Information

Coasting is the process of driving a vehicle without the brake pedal and the accelerator depressed. Coasting uses the inertia of driving energy instead of the vehicle power.

Using one pedal driving

Pull and hold the left paddle shifter (\leftarrow +) for over 1 seconds while coasting to enable the one pedal driving mode.

- Release the paddle shifter when the vehicle speed is above 3 km/h (2 mph) to return to the previously set regenerative braking level.
- If the vehicle speed is below 3 km/h (2 mph), the vehicle will keep engaging the brake although the driver releases the paddle shifter.
- Releasing the paddle shifter after the vehicle comes to a stop maintains the vehicle stationary.

CAUTION

- The vehicle may not come to a stop although the one pedal driving function is active, depending on the condition of the vehicle and the road. Check the surroundings and depress the brake pedal to decelerate.
 - If the driver depresses the accelerator while pulling and holding the left paddle shifter (\leftarrow +) to increase the braking level, one pedal driving function will work like i-PEDAL function. In this case, the vehicle speed is no longer controllable through the paddle shifter.
-

One pedal driving limitations

In the following conditions, the vehicle may not come to a stop although the one pedal driving function is active. Depress the brake pedal to stop the vehicle.

- When driving on a slope, or when the vehicle is repeatedly driven and stopped.
- When the vehicle is driving through the end of the slope.
- When driving on a slippery surface such as an icy, rainy, or muddy road.
- When the wheels are not properly aligned.
- When a wheel slip or wheel spin occurs.
- When the weight on board is too heavy.
- When the vehicle is tilted to one side.
- When the tire is worn out too much.

Automatic engagement of EPB

Use one pedal driving function to bring the vehicle to a stop and automatically engage the Electronic Parking Brake (EPB).

After the vehicle is stopped, EPB is automatically engaged when any of the following conditions are satisfied

- The driver's seatbelt is unfastened and the driver's door is open.
- The gear shifts to N (Neutral).
- The hood is open.
- The tailgate is open.
- 5 minutes have passed after the vehicle has stopped.
- One pedal driving is limited due to other reasons.

Using i-PEDAL

i-PEDAL assists the driver to accelerate, decelerate, and stop the vehicle with only the accelerator pedal.

Turning on/off the i-PEDAL

• Turning on i-PEDAL:

Pull the left paddle shifter ($\pm D$) once when the regenerative braking level is at 3. i-PEDAL is turned on and the instrument cluster displays the "i-PEDAL". i-PEDAL is not available while the smart regeneration system is ON. Turn off the smart regeneration system first before using i-PEDAL.

• Turning off i-PEDAL:

Pull the right paddle shifter ($\pm R$) once while the function is ON. Otherwise, shift the gear to R (reverse) then to D (drive) while the function is ON. i-PEDAL is disabled and regenerative braking level is set to 3.

CAUTION

Depending on the vehicle and road condition, the vehicle may not come to a stop although the i-PEDAL function is active. Check for the surroundings and depress the brake pedal to control the vehicle speed.

Do not use i-PEDAL on slippery roads.

i-PEDAL limitations

In the following conditions, the vehicle may not come to a stop although the i-PEDAL is properly activated. Depress the brake to stop the vehicle.

- When driving on a slope, or when the vehicle is repeatedly driven and stopped
- When the vehicle is driving through the end of the slope
- When driving on a slippery surface such as an icy, rainy, or muddy road
- When the wheels are not properly aligned
- When a wheel slip or wheel spin occurs
- When the weight on board is too heavy
- When the vehicle is tilted to the side
- When the tire is worn out too much

Smart regeneration system

The smart regeneration system recognizes vehicle-to-vehicle distance, road gradient and controls the regenerative braking level while coasting. It reduces unnecessary depressing of pedals to improve energy efficiency and driver convenience.

i Information

- Coasting is the process of driving a vehicle without the brake pedal and the accelerator pedal depressed. Coasting uses the inertia of driving energy instead of the vehicle power.
- The regenerative braking system uses the electric motor to engage the brake. The electric motor converts the kinetic energy generated from decelerating the vehicle to electricity and charges the high voltage battery.

Smart regeneration system on/off

Operate the paddle shifter as shown below to use the smart regeneration system.

- **Turning on the smart regeneration system:** While the READY indicator is ON, shift the gear to D (drive), and pull and hold the right paddle shifter (\rightarrow D) for over 1 second.



The smart regeneration system is ON and the regenerative braking level is displayed as 'AUTO'.

- **Turning off the smart regeneration system:** While the smart regeneration system is ON, pull and hold the right paddle shifter (\rightarrow D) for over 1 second. The instrument cluster will display the regenerative braking level instead of 'AUTO', and the smart regeneration system turns off.

i-PEDAL is not available while the smart regeneration system is ON. Turn off the smart regeneration system first before using i-PEDAL.

Smart regeneration system operating condition

When the regenerative braking level is displayed as 'AUTO', the system automatically controls the regenerative braking level under the following conditions:

- The road gradient changes.
- Distance from the vehicle ahead reduces or increases.
- Speed of the vehicle ahead reduces or increases.

CAUTION

When the Forward Safety warning light is ON, the smart regeneration system does not work properly. Depress the brake pedal to decelerate.

Smart regeneration level settings



The instrument cluster displays 'AUTO' (2) when the smart regeneration system is ON. Depending on the conditions, the system adjusts the regenerative braking level (3). The sky blue (1) indicator light illuminates when the vehicle recognizes a vehicle.

Smart regeneration default setting

If level 0 is selected for the regenerative braking system, the system turns to level 1 once you start the vehicle again.

Pausing smart regeneration system

The smart regeneration system is temporarily turned off in the following conditions. While the system is turned off, the driver must keep eyes on the surroundings and depress the brake pedal to decelerate.

- The gear is shifted to N (Neutral), R (Reverse) or P (Park).
- Smart Cruise Control is ON.
- ESC (Electronic Stability Control) is operating.
- ABS is operating.

Front sensors (Front radar)



(1) Front radar

The front radar recognizes the distance from the vehicle ahead to control the regenerative braking intensity. When the front radar is covered with snow, rain, or other foreign substances, the performance of the sensors may reduce, and the smart regeneration system may turn off. Always keep the sensors clean.

System warning due to sensor problems

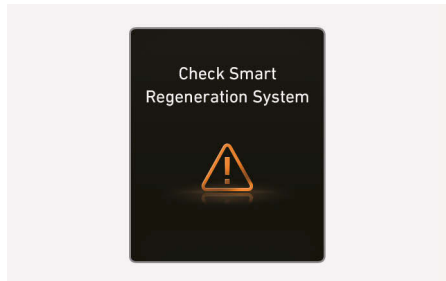

If the smart regeneration system is turned off due to the front radar being covered with foreign substances or due to other causes, the "**Check Smart Regeneration System**" warning message appears. Also the regenerative braking level is displayed instead of 'AUTO'.

The system operates normally when such foreign material is removed, and the system is turned on by pulling and holding the right paddle shifter (Ⓛ) for over 1 second.

If the smart regeneration system does not operate normally after the front radar has been uncovered or unblocked, we recommend that you visit an authorized HYUNDAI dealer for inspection.

Smart regeneration system precautions

- Always monitor the distance to vehicles ahead on the road. The smart regeneration system is not a substitute for safe driving practices, but a supplemental function only.
- Always maintain a safe distance from the vehicles ahead and adjust your vehicle speed to the road conditions. The smart regeneration system may not recognize unexpected and sudden situations or complex driving situations.

General precautions

- Always maintain a safety distance from the vehicle ahead, and adjust your vehicle speed depending on the road conditions.
- Always prepare for unexpected situations and depress the brake pedal to decelerate when necessary. The smart regeneration system cannot react to pedestrians, vehicles making a sudden stop, and vehicles coming from the opposite lane.
- If the vehicle ahead frequently changes the lane, keep your eyes forward to be prepared for hazardous situations. In this case, the smart regeneration system may respond late and may inappropriately response to vehicle movements from the side lanes.
- The driver must depress the brake pedal when stopping the vehicle.
- Depress the brake pedal to decelerate in the following conditions when:
 - The front part of the vehicle is lifted up because of the cargo loaded on the rear part of the vehicle.
 - You are operating the steering wheel.
 - You are not driving in the center of the lane.
 - You are driving on a that is too narrow or too curved.

- The smart regeneration system may be temporarily turn off when exposed to strong electromagnetic waves.

Front sensor precautions

- Make sure that no physical impact is applied to the sensor or its surroundings. If the sensor is dislocated due to the shock, the system may not work properly and the instrument cluster may not display any warnings. If the sensor is exposed to physical impacts, we recommend that you visit an authorized HYUNDAI dealer for inspection.
- The sensors and its surroundings, the sensor covers, and the vehicle grille should always be kept clean.
- Do not attach any accessories such as molding or stickers on the sensor and its detection range, or change the vehicle grille. It may affect sensor performance.
- Always use genuine parts for the sensor cover, and do not paint it.
- Use soft fabric to prevent damage to the sensor cover when washing the car.
- Do not spray the sensor or the surrounding with high pressure water.

Precautions for vehicle recognition

- The front sensors may suddenly recognize the foregoing vehicle when the smart regeneration system reacts slowly, or the vehicle is going through the end of a slope or curve. In this case, the regenerative braking intensity is increased and the vehicle may slow down.

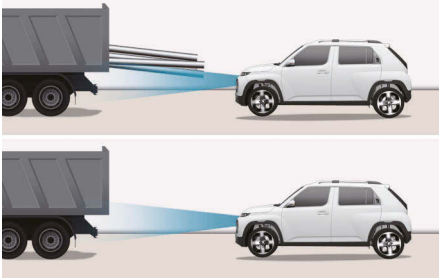

- The front sensors may be unable to recognize the vehicle ahead in the following situations even if it is on the same lane.
 - Narrow vehicles such as motorcycles or bicycles
 - Vehicles offset to one side
 - Slow-moving vehicles or sudden decelerating vehicles
 - Vehicles with small rear profile such as trailers with no loads
- When the vehicle in front of the foregoing vehicle is at a stop and the foregoing vehicle changes the lane, the front sensors may be unable to recognize the stopped vehicle.

Precautions on the curves

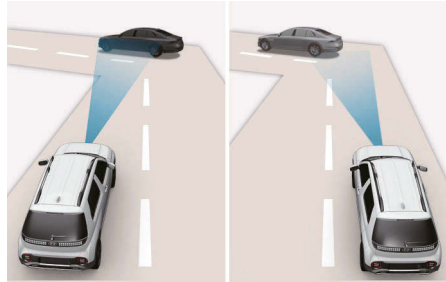

- The front sensors may be unable to recognize the foregoing vehicle if you are coasting on a curve. The regenerative braking intensity may automatically be lowered, which may accelerate the vehicle.
- On a curved road, the front sensors may recognize the vehicles on the other lane as the foregoing vehicle of the same lane. It may increase the regenerative braking intensity and the vehicle may decelerate. Check the surroundings and depress the accelerator to prevent unnecessary reduce of speed.
- If the front sensors suddenly recognize the vehicle ahead, regenerative braking intensity may rise and the vehicle may decelerate.

Precautions on the slope

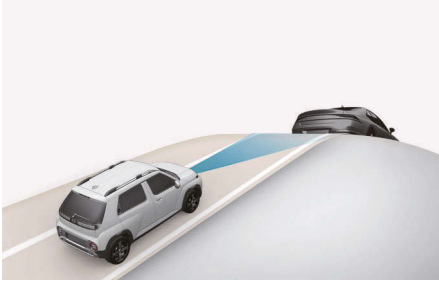

- When the vehicle is coasting through the end of a slope or where the gradient is changing, the front sensors may be unable to recognize the vehicle ahead. It may adjust the regenerative braking intensity and change the vehicle speed.
- When driving up or down the slope, check for the surroundings and depress the brake pedal to decelerate.

Precautions for shifting lanes

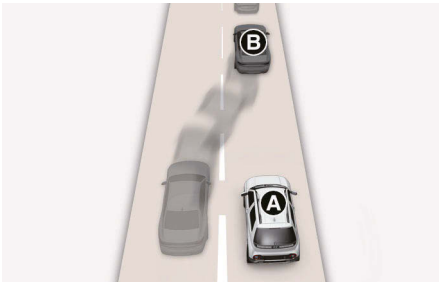

- If a vehicle [B] on the next lane is moving into the front of your vehicle [A], the front sensors can only recognize the vehicle when it is completely inside the detection range.
- The front sensors may recognize the vehicles late that intervene suddenly.

Braking system

Power-assist brakes

Your vehicle has power-assisted brakes that adjust automatically through normal usage.

In the event of a vehicle power failure, the power assist for the brakes will not work. You can still stop your vehicle, but it will require greater force and increased pedal travel than normal. The stopping distance, however, will be longer than with power brakes.

When the vehicle is not running, the reserve brake power is partially depleted each time the brake pedal is depressed. Avoid pumping the brake pedal when the power assist has been interrupted.

i Information

- When the brake pedal is depressed under certain driving conditions or weather conditions, you may temporarily hear a noise. This is normal and does not indicate a problem with your brakes.
- While driving on a road with deicing chemicals, brake noise or abnormal tire wear may occur due to deicing chemicals. In a safe traffic condition, additionally apply the brakes to remove deicing chemicals on the brake discs and pads.

WARNING

Take the following precautions:

- Do not drive with your foot resting on the brake pedal. This may create abnormal high brake temperatures, excessive brake lining and pad wear, and increased stopping distances.
- When descending down a long or steep hill, use the paddle shifter and manually downshift to a lower gear in order to control your speed without using the brake pedal excessively. Applying the brakes continuously will cause the brakes to overheat and may result in a temporary loss of braking performance.
- Wet brakes may impair the vehicle's ability to safely slow down and the vehicle may also pull to one side when the brakes are applied. Applying the brakes lightly indicates whether they have been affected in this way. Always test your brakes in this fashion after driving through deep water. To dry the brakes, lightly tap the brake pedal to heat up the brakes while maintaining a safe forward speed until brake performance returns to normal. Avoid driving at high speeds until the brakes function correctly.

NOTICE

- Do not continue depressing the brake pedal if the vehicle is off (READY indicator OFF). The battery may be discharged.
- Noise and vibration generated during braking is normal.
- Under normal operation, electric brake pump noise and motor vibration may occur temporarily in below cases.
 - When the pedal is depressed suddenly.
 - When the pedal is repeatedly depressed in short intervals.

- When the ABS function is activated while braking.

Disc brakes wear indicator

When your brake pads are worn and new pads are required, you may hear a high pitched warning sound from your front or rear brakes. You may hear this sound come and go or it may occur whenever you depress the brake pedal.

NOTICE

To avoid costly brake repairs, do not continue to drive with worn brake pads.

Information

Always replace brake pads as complete front or rear axle sets.

Electronic Parking Brake (EPB)

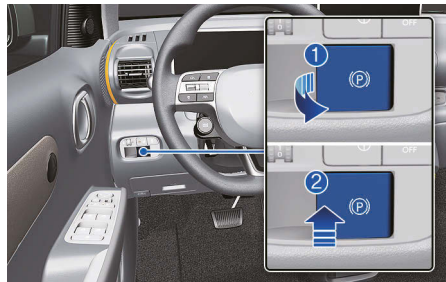

- (1) Applying the parking brake
- (2) Releasing the parking brake

Applying the parking brake

To apply EPB (Electronic Parking Brake):

1. Depress and hold the brake pedal.
2. Pull up the EPB switch.

Make sure the Parking Brake warning light comes on.

EPB (Electronic Parking Brake) may be automatically applied when:

- Requested by other systems.
- The driver turns the vehicle off while Auto Hold is operating.
- The gear is shifted to P (Park).

Emergency braking

If there is a problem with the brake pedal while driving, emergency braking is possible by pulling up and holding the EPB switch. Braking is possible only while you are holding the EPB switch. However, braking distance may be longer than normal.

WARNING

To reduce the risk of serious injury or death, do not operate the EPB while the vehicle is moving except in an emergency situation. It may damage the brake system and cause a collision.

Information

During emergency braking, the Parking Brake warning light illuminates and you may hear a clicking noise.

NOTICE

If you notice a noise or burning smell when the EPB is used for emergency braking, we recommend that your vehicle be inspected by an authorized HYUNDAI dealer.

Releasing the parking brake

To release EPB (Electronic Parking Brake):

1. Press the Start/Stop button to ON or START position.
2. Press the EPB switch while depressing the brake pedal.

Make sure the Parking Brake warning light goes off.

To release EPB (Electronic Parking Brake) automatically:

- Gear in P (Park) or in N (Neutral)

With the vehicle running, depress the brake pedal and shift out of P (Park) or N (Neutral) to R (Reverse) or D (Drive). Make sure the doors, hood, and tailgate are closed and the seat belt is fastened.

Information

- You can engage EPB even though the Start/Stop button is in the OFF position (only if battery power is available), but you cannot release it.
- Depress the brake pedal and release the parking brake manually with the EPB switch before you drive downhill or when backing up.

NOTICE

- If the Parking Brake warning light is still on even though the EPB has been released, we recommend that your vehicle be inspected by an authorized HYUNDAI dealer.
- Do not drive your vehicle with EPB applied. It may cause excessive brake pad and brake rotor wear.

Warning messages

To release EPB, fasten seatbelt and close door, hood and tailgate

If the driver's seat belt is unfastened, or the hood, tailgate, doors are open, and you try to drive with EPB applied, a warning sounds and a message appears.

WARNING

To prevent serious injury or death from unintended vehicle movement:

- Always come to a complete stop and continue to depress the brake pedal before parking, shift the gear into P (Park), pull up the EPB switch, and press the Start/Stop button to the OFF position. Take the key with you when leaving the vehicle.
 - Never allow anyone who is unfamiliar with the vehicle to touch the EPB switch.
 - Only release EPB when you are seated inside the vehicle with your foot firmly on the brake pedal.
-

NOTICE

Driving with the parking brake on may overheat the braking system and cause premature wear or damage to brake parts.

Information

- A clicking sound may be heard while operating or releasing the EPB. These conditions are normal and indicate that EPB is functioning properly.
 - When leaving your keys with a parking attendant or assistant, make sure to inform him/her how to operate the EPB.
-

EPB malfunction

Electronic Parking Brake (EPB) warning light illuminates if the Start/Stop button is in the ON position and goes off in about 3 seconds if the system is operating normally.

If the EPB warning light remains on, comes on while driving, or does not come on when the Start/Stop button is ON, the EPB may have malfunctioned.

If this occurs, we recommend that your vehicle be inspected by an authorized HYUNDAI dealer.

The EPB warning light may illuminate when the ESC indicator comes on to indicate that ESC is not working properly, but it does not indicate a malfunction of EPB.

Information

- If the Parking Brake warning light does not illuminate or blinks after the EPB switch has been pulled, the EPB may not be applied.
 - If the EPB warning light is still on or the Parking Brake warning light blinks when the EPB warning light is on, press the switch, and then pull it up. Repeat this one more time. If the EPB warning does not go off, we recommend that your vehicle be inspected by an authorized HYUNDAI dealer.
-

Parking brake warning light



This light illuminates when the Parking Brake is applied with the Start/Stop button in the START or ON position.

Before driving, make sure the Parking Brake is released and the Parking Brake warning light is OFF.

If the Parking Brake warning light remains on after the Parking Brake is released while the vehicle is running, there may be a malfunction in the brake system.

If possible, stop driving the vehicle immediately. If that is not possible, use extreme caution while operating the vehicle and only continue to drive the vehicle until you can reach a safe location.

Auto Hold

Auto Hold maintains the vehicle in a standstill even though the brake pedal is not depressed after the driver brings the vehicle to a complete stop by depressing the brake pedal.

i Information

When the vehicle is restarted, the last setting for Auto Hold is applied.



To apply:

1. With the driver's door, hood, and tailgate closed, depress the brake pedal and then press the AUTO HOLD button. The white AUTO HOLD indicator comes on and the system is in standby.
2. When you stop the vehicle completely by depressing the brake pedal, Auto Hold maintains the brake pressure to hold the vehicle stationary. The indicator changes from white to green.
 - The vehicle remains stationary even if you release the brake pedal.
 - If EPB is applied, Auto Hold is released.

To release:

If you depress the accelerator pedal with the gear in D (Drive) or R (Reverse), the Auto Hold is released automatically and the vehicle starts to move. The ^{AUTO}_{HOLD} indicator changes from green to white.

WARNING

Always look around your vehicle before depressing the accelerator pedal to release Auto Hold.

To cancel:

1. Depress and hold the brake pedal.
2. Press the **AUTO HOLD** button.

The ^{AUTO}_{HOLD} indicator turns off.

WARNING

To prevent unintended vehicle movement, always depress your foot on the brake pedal to cancel the Auto Hold before you:

- Drive downhill.
 - Drive the vehicle in R (Reverse).
 - Park the vehicle.
-

Information

The Auto Hold does not operate when:

- The driver's door or hood is opened.
 - The tailgate is opened.
 - The gear is in P (Park) or R(Reverse) (Shift lever type only).
 - EPB is applied.
 - The Auto Hold automatically switches to EPB when:
 - The driver's door or hood is opened.
 - The tailgate is opened.
 - The vehicle is in a standstill for more than 10 minutes.
-

- The vehicle is standing on a steep slope.
- The vehicle moves several times.

The Parking Brake warning light comes on, the ^{AUTO}_{HOLD} indicator changes from green to white, and a warning sounds and a message appears to inform you that EPB has been automatically engaged. Before driving, depress the brake pedal, check the surrounding area, and release the parking brake manually with the EPB switch.

NOTICE

If the ^{AUTO}_{HOLD} indicator changes to yellow, or the driver's door, hood, or tailgate open detection system malfunctions, Auto Hold does not work properly. We recommend that you contact an authorized HYUNDAI dealer.

NOTICE

If there is a malfunction with the driver's door or hood open detection system, Auto Hold may not work properly.

We recommend that you contact an authorized HYUNDAI dealer.

Warning messages

Parking brake automatically applied

When EPB is applied while Auto Hold is activated, a warning sounds and a message appears.

AUTO HOLD Turning off! Press brake pedal

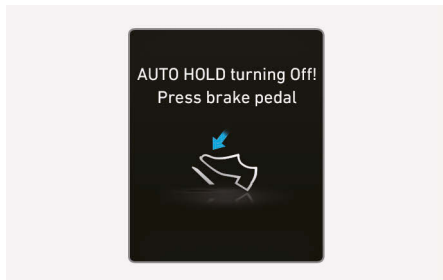

When the conversion from Auto Hold to EPB is not working properly, a warning sounds and a message appears.

CAUTION

If warning message is displayed, the Auto Hold and EPB may not operate normally. For your safety, depress the brake pedal.

Press brake pedal to deactivate AUTO HOLD

If you did not apply the brake pedal when you release Auto Hold by pressing the AUTO HOLD button, a warning sounds and a message appears.

Press the AUTO HOLD button while depressing the brake pedal.

Brake Disc Cleaning

Use the Brake Disc Cleaning function if noise is generated when depressing the brake while driving or if the brake disc gets rusty. It helps reduce the noise and rust. Regenerative braking is restrained while Brake Disc Cleaning is operated, which may lower the electric energy efficiency.

Press and hold the AUTO HOLD button for over 3 seconds.

- Brake Disc Cleaning starts operating when the message "**Brake Disc Cleaning**" is displayed on the instrument cluster.
- Regenerative braking is restrained while the brake is depressed about 10 times while driving (it may differ depending on driving conditions). It helps reduce the noise and rust.
- Brake Disc Cleaning function will turn off automatically when the operation is completed. It can also be turned off before operation is completed by turning off the vehicle or pressing the AUTO HOLD button for over 3 seconds.

Anti-Lock Brake System (ABS)

WARNING

Anti-Lock Braking System (ABS) or Electronic Stability Control (ESC) system does not prevent accidents due to improper or dangerous driving maneuvers. Even though vehicle control is improved during emergency braking, always maintain a safe distance between you and objects ahead of you. Always reduce the vehicle speed in extreme road conditions.

The braking distance for vehicles equipped with ABS or ESC may be longer than for those without these systems in the following road conditions.

Drive your vehicle at reduced speeds during the following conditions:

- Rough, gravel or snow-covered roads.
- On roads where the road surface is pitted or has different surface height.
- Tire chains are installed on your vehicle.

Never test the safety features of an ABS or ESC equipped vehicle by high speed driving or cornering. It may cause a collision and endanger the safety of yourself or others.

ABS is an electronic braking system that helps prevent a braking skid. ABS allows the driver to steer and brake at the same time.

Using ABS

To obtain the maximum benefit from your ABS in an emergency situation, do not attempt to modulate your brake pressure and do not try to pump your brakes. Depress your brake pedal as hard as possible.

When you apply your brakes under conditions that may lock the wheels, you may hear sounds from the brakes, or feel a corresponding sensation in the brake pedal. This is normal and it means your ABS is active.

ABS does not reduce the time or distance it takes to stop the vehicle.

Always maintain a safe distance from the vehicle in front of you.

ABS does not prevent a skid that results from sudden changes in direction, such as trying to take a corner too fast or making a sudden lane change. Always drive at a safe speed for the road and weather conditions.

ABS cannot prevent a loss of stability. Always steer moderately when braking hard. Severe or sharp steering wheel movement can still cause your vehicle to veer into oncoming traffic or off the road.

On loose or uneven road surfaces, operation of the anti-lock brake system may result in a longer stopping distance than for vehicles equipped with a conventional brake system.

The ABS (ABS) warning light stays on for several seconds after the Start/Stop button is in the ON position.

During that time, ABS goes through self-diagnosis and the light goes off if everything is normal. If the light stays on, we recommend that you contact an authorized HYUNDAI dealer as soon as possible.

! WARNING

If the ABS (ABS) warning light is on and stays on you may have a problem with the ABS. Your power brakes work normally. To reduce the risk of serious injury or death it is recommended to contact your authorized HYUNDAI dealer as soon as possible.

NOTICE

When you drive on a road having poor traction, such as an icy road, and apply your brakes continuously, ABS is active continuously and the ABS (ABS) warning light may illuminate. Pull your vehicle over to a safe place and turn off the vehicle.

Restart the vehicle. If the ABS warning light is off, then your ABS system is normal.

If not, we recommend that you contact an authorized HYUNDAI dealer as soon as possible.

i Information

When you jump start your vehicle because of a drained battery, the ABS (ABS) warning light may turn on at the same time. It does not mean your ABS is malfunctioning. Have the battery recharged before driving the vehicle.

Electronic Stability Control (ESC)

The Electronic Stability Control (ESC) system helps stabilize the vehicle during cornering maneuvers.

ESC checks where you are steering and where the vehicle is actually going. ESC applies braking pressure to any one of the vehicle's brakes and intervenes in the electric vehicle control system to assist the driver with keeping the vehicle on the intended path. It is not a substitute for safe driving practices. Always adjust your speed and driving to the road conditions.

! WARNING

Never drive too fast for the road conditions or too quickly when cornering. The ESC system does not prevent a collision.

Excessive speed in turns, abrupt maneuvers, and hydroplaning on wet surfaces may result in severe collisions.

ESC operation

ESC ON condition

When the Start/Stop button is in the ON position, the ESC and the ESC OFF indicator lights illuminate for about 3 seconds. After both lights go off, ESC is enabled.



When the ESC is operating, the ESC indicator light blinks:

- When you apply your brakes under conditions that may lock the wheels, you may hear sounds from the brakes, or feel a corresponding sensation in the brake pedal.
- When ESC activates, the vehicle may not respond to the accelerator as it does under routine conditions.

ESC OFF condition



To cancel ESC operation:

- State 1

Press the ESC OFF button briefly. The ESC OFF indicator light and the message, "**Traction and Stability Control limited**" illuminates.

The traction control function of ESC (electric vehicle control management) is disabled, but the brake control function of ESC (braking management) still operates.

- State 2

Press and hold the ESC OFF button continuously for more than 3 seconds. The ESC OFF indicator light and/or message "**Traction and Stability Control disabled**" illuminates and a warning chime sounds. Both the traction control function of ESC (electric vehicle control management) and the brake control function of ESC (braking management) are disabled.

If the Start/Stop button is pressed to the OFF position when ESC is off, ESC remains off. Upon restarting the vehicle, ESC automatically turns on again.

ESC indicator light (blinks)



ESC OFF indicator light (comes on)



When the Start/Stop button is in the ON position, the ESC indicator light illuminates, then goes off if the ESC system is operating normally.

The ESC indicator light blinks whenever ESC is operating.

If the ESC indicator light stays on, we recommend that your vehicle be inspected by an authorized HYUNDAI dealer as soon as possible.

The ESC OFF indicator light comes on when ESC is turned off.

⚠ WARNING

When ESC is blinking, this indicates ESC is active:

- Drive slowly and NEVER attempt to accelerate.
- Never turn off ESC while the ESC indicator light is blinking. You may lose control of the vehicle and collide.

NOTICE

Driving with wheels and tires with different sizes may cause the ESC system to malfunction. Before replacing tires, make sure all four tires and wheels are the appropriate size for your vehicle. Never drive the vehicle with different sized wheels and tires installed.

ESC OFF usage**When Driving**

The ESC OFF mode should only be used briefly to help free the vehicle if stuck in snow or mud, by temporarily stopping operation of ESC, to maintain wheel torque.

To turn off ESC while driving, press the ESC OFF button while driving on a flat road surface.

NOTICE

To prevent damage to the reduction gear:

- Do not allow wheel(s) of one axle to spin excessively while the ESC, ABS, and Parking Brake warning lights appear. The repairs would not be covered by the vehicle warranty. Reduce motor power and do not spin the wheel(s) excessively while these lights appear.
- When operating the vehicle on a dynamometer, make sure ESC is turned off (ESC OFF light illuminated).

i Information

Turning ESC off does not affect ABS or standard brake system operation.

Vehicle Stability Management (VSM)

Vehicle Stability Management is a function of the Electronic Stability Control (ESC) system. It helps the vehicle stay stable when accelerating or braking suddenly on wet, slippery and rough roads where traction over the four tires can suddenly become uneven.

⚠ WARNING

Take the following precautions when using Vehicle Stability Management:

- ALWAYS check the speed and the distance to the vehicle ahead. VSM is not a substitute for safe driving practices.
- Never drive too fast for the road conditions. VSM does not prevent accidents. Excessive speed in bad weather, on slippery and uneven roads can result in severe accidents.

VSM operation**When operating**

When you apply your brakes under conditions that can activate ESC, you may hear sounds from the brakes, or feel a corresponding sensation in the brake pedal. This is normal and it means your VSM is active.

i Information

VSM does not operate when:

- Driving on a banked road such as gradient or incline.
- Driving in reverse.
- The ESC OFF indicator light is on.

- The MDPS (Motor Driven Power Steering) warning light (⚠️) is on or blinks.
-

VSM OFF condition

To cancel VSM operation, press the ESC OFF button. ESC OFF (⚠️) indicator light illuminates.

To turn on VSM again, press the ESC OFF button again. The ESC OFF indicator light goes out.

⚠️ WARNING

If the ESC (⚠️) indicator light or MDPS (⚠️) warning light stays illuminated or blinks, your vehicle may have a malfunction with the VSM system. When the warning light illuminates, we recommend that your vehicle be inspected by an authorized HYUNDAI dealer as soon as possible.

NOTICE

Driving with wheels and tires with different sizes may cause the VSM system to malfunction. Before replacing tires, make sure all four tires and wheels are the same size. Never drive the vehicle with different sized tires and wheels installed.

Hill-Start Assist Control (HAC)

Hill-Start Assist Control helps prevent the vehicle from rolling backwards when starting from a stop on a hill. The system operates the brakes automatically for about 2 seconds (maximum of 5 seconds when the accelerator pedal is slightly depressed during HAC operation) and releases the brake after 2 seconds or when the accelerator pedal is depressed.

⚠️ WARNING

- Always be ready to depress the accelerator pedal when starting from a stop on an uphill slope. Hill-Start Assist Control activates only for about 2 seconds.
 - Hill-Start Assist Control does not operate when the gear is shifted to P (Park) or N (Neutral).
 - Hill-Start Assist Control activates even when the ESC (Electronic Stability Control) is off. It does not activate, if the ESC is not operating normally.
 - Be aware that restarting after a stop on a steep hill would be difficult if the vehicle temperature is high or the total loaded vehicle weight is high.
 - When driving on a steep hill, you need to control the speed moderately. Make sure to check the surroundings before restarting your vehicle after a complete stop. Minimize vehicle weight for your safety.
-

Emergency Stop Signal (ESS)

Emergency Stop Signal alerts the driver behind by blinking the stop lights, while sharply and severely braking.

ESS operation

The stop light blinks quickly when:

- The vehicle suddenly stops. (The deceleration power exceeds 7 m/s^2 , and the driving speed exceeds 55 km/h (34 mph).)
- ABS is activated.

ESS off

After the blinking of the stop lights, the hazard warning flasher automatically turns ON when:

- Driving speed is under 40 km/h (25 mph) and the sudden braking situation is over.
- ABS is deactivated.

The hazard warning flasher turns OFF when:

- The vehicle drives at a low speed for a certain period of time.
- The driver can manually turn OFF the hazard warning flasher by pressing the button.

CAUTION

Emergency Stop Signal does not activate, when the hazard warning flashers are already on.

Multi-Collision Brake (MCB)

Multi-Collision Brake controls the brake automatically in the event of an accident where the airbag deploys to reduce the risk of additional accidents that may occur.

MCB operation

- From the time the airbag deploys, Multi-Collision Brake monitors the depression intensity of the brake pedal and accelerator pedal for a short period. The system operates when the following conditions are met:
 - Vehicle speed is under 180 km/h (112 mph) at the time of collision.
 - The brake pedal and accelerator pedal is hardly depressed.
- When the driver steps on the brake pedal over a certain level while Multi-Collision Brake is active, the braking power takes priority over automatic braking by Multi-Collision Brake system. However, if the driver takes his/her foot off the brake pedal, automatic braking by Multi-Collision Brake system will maintain automatic braking.

MCB off

Multi-Collision Brake is canceled in the following situations:

- The accelerator pedal is depressed over a certain level.
- The vehicle stops.
- ESC (Electronic Stability Control) or electronic devices has malfunctioned.
- In a situation system cannot operate normally.
- 10 seconds have passed since the brake has been controlled automatically by Multi-Collision Brake system.

WARNING

- Multi-Collision Brake decreases vehicle speed after a collision and reduces the risk of a second collision, but it does not prevent a second collision. You may drive away from the collision spot to avoid other dangerous situations by depressing the accelerator pedal.
 - After the vehicle is stopped by Multi-Collision Brake, the system stops controlling the brakes. Depending on the situation, the driver should depress the brake or the accelerator pedal to prevent further accidents.
-

Brake Assistant System (BAS)

The Brake Assistant System provides additional pressure when the brake pedal is momentarily and strongly depressed in a situation sudden braking is required while driving.

The Brake Assistant System reduces the time for ABS (Anti-Lock Brake System) control to enter and consequently reduces the braking distance, by providing additional pressure up to the point of ABS intervention.

WARNING

The system may not operate depending on driver's driving habit, driving speed, the degree to which the brake pedal is depressed and the road surface condition.

Good braking practices

WARNING

Whenever leaving the vehicle or parking, always come to a complete stop and continue to depress the brake pedal. Shift the gear to the P (Park) position, then apply the EPB, and press the Start/Stop button to the OFF position.

Vehicles parked with the EPB not applied or not fully engaged may roll inadvertently and may cause injury to the driver and others. ALWAYS apply the parking brake before exiting the vehicle.

Wet brakes can be dangerous! The brakes may get wet if the vehicle is driven through standing water or if it is washed. Your vehicle will not stop as quickly if the brakes are wet. Wet brakes may cause the vehicle to pull to one side.

To dry the brakes, apply the brakes slightly until the braking action returns to normal. If the braking action does not return to normal, stop as soon as it is safe to do so. We recommend that your vehicle be inspected by an authorized HYUNDAI dealer.

DO NOT drive with your foot resting on the brake pedal. Even light, but constant pedal pressure can result in the brakes overheating, brake wear, and possibly even brake failure.

If a tire goes flat while you are driving, apply the brakes gently and keep the vehicle pointed straight ahead while you slow down. When you are moving slowly enough for it to be safe to do so, pull off the road and stop in a safe location.

Keep your foot firmly on the brake pedal when the vehicle is stopped to prevent the vehicle from rolling forward.

Drive mode integrated control system

+ if equipped

Drive mode



The drive mode may be selected according to the driver's preference or road conditions.

The system resets to **NORMAL** mode, when the vehicle is restarted.

i Information

If there is a problem with the instrument cluster, the drive mode is in **NORMAL** mode and may not change to **SPORT** mode.

The mode changes, as the following, whenever the **DRIVE MODE** button is turned to the right or left.

- **ECO ↔ NORMAL ↔ SPORT ↔ SNOW**

Drive mode features

NORMAL mode

NORMAL mode provides smooth driving and comfortable riding.

NORMAL mode is selected, it does not appear on the instrument cluster.

ECO mode

ECO mode helps improve energy efficiency for eco-friendly driving.

Energy efficiency varies according to the driver's driving habit and road condition.

- When **ECO** mode is selected, the **ECO** indicator illuminates on the instrument cluster.
- The drive mode resets to **NORMAL** mode when the vehicle is restarted.
- When **ECO** mode is activated:
 - The acceleration response may be slightly reduced if the accelerator pedal is depressed moderately.
 - The air conditioner performance may be limited.

The above situations are normal conditions when **ECO** mode is activated to help improve energy efficiency.

SPORT mode

SPORT mode provides sporty but firm riding.

In **SPORT** mode, the energy efficiency may decrease.

- When the **SPORT** mode is selected, the **SPORT** indicator illuminates on the instrument cluster.
- The drive mode resets to **NORMAL** mode when the vehicle is restarted.

SNOW mode

SNOW mode helps to drive on slippery roads.

The motor's driving power is properly distributed to the wheels, to help start the vehicle stably on slippery roads or keep tires from slipping.

- The drive mode resets to **NORMAL** mode when the vehicle is restarted.

Drive mode characteristic

The characteristic of each components varies depending on which drive mode is selected.

Drive mode	SNOW	NORMAL	ECO	SPORT
Characteristics	Snow optimizing available traction mode	Normal driving mode	High electric energy efficiency mode	Sporty driving mode
Switch activation	Turn right or left			
Indicator on the instrument cluster	SNOW	-	ECO	SPORT
Climate control system	NORMAL	NORMAL	ECO/NORMAL	NORMAL
Regenerative braking level	0-1	0-4		

Active air flap



Active air flap system controls the air flap below the front bumper to cool the vehicle parts and improve energy efficiency.

i Information

Active air flap system could be activate regardless of the vehicle condition.(Parking, driving, charging, etc.)

Malfunction

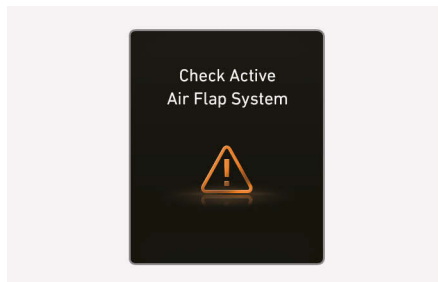

The active air flap system may not operate normally if the air flap is temporarily opened due to foreign factors or if the controller is contaminated by snow or rain, etc.

When "**Check Active Air Flap System**" is popped up on display, stop the vehicle in a safe place and check the status of the air flap.

Start the vehicle after performing the necessary work like foreign matter removal and waiting 10 minutes. If the pop-up remains up we recommend that you contact an authorized HYUNDAI dealer.

! CAUTION

- Regardless of the pop-up, if the air flaps aren't in the same position, stop the vehicle and wait for 10 minutes and start the vehicle and inspect the air flap.
- The active air flap system is actuated by motors. Do not disturb actuation or apply force excessively. It may cause failure.

Special driving conditions

Hazardous driving conditions

When hazardous driving elements are encountered such as water, snow, ice, mud and sand, take the following precautions:

- Drive cautiously and maintain a longer braking distance.
- Avoid abrupt braking or steering.
- When your vehicle is stuck in snow, mud, or sand, accelerate slowly to avoid unnecessary wheel spin.
- Put sand, rock salt, tire chains or other non-slip materials under the wheels to provide additional traction while the vehicle becomes stuck in ice, snow, or mud.

WARNING

Changing the tire speed suddenly could cause the tires to skid while driving on slippery surface. Be careful when driving on slippery surfaces.

Rocking the vehicle

If it is necessary to rock the vehicle to free it from snow, sand, or mud, first turn the steering wheel right and left to clear the area around your front wheels. Then, shift back and forth between R (Reverse) and a forward gear.

Try to avoid spinning the wheels, and do not race the vehicle.

To prevent reduction gear wear, wait until the wheels stop spinning before shifting gears. Release the accelerator pedal while shifting, and press lightly on the accelerator pedal while the reduction gear is in gear. Slowly spinning the wheels in forward and reverse directions causes a rocking motion that may free the vehicle.

WARNING

- Always turn off the ESC system before rocking the vehicle. If the vehicle is stuck and excessive wheel spin occurs, the temperature in the tires may increase very quickly. If the tires become damaged, a tire blow out or tire explosion may occur - you and others may be injured. Do not attempt this procedure if people or objects are near the vehicle.
 - If you attempt to free the vehicle, the vehicle may overheat quickly, possibly causing a motor compartment fire or other damage. Try to avoid spinning the wheels as much as possible to prevent overheating of the tires or the motor. DO NOT allow the vehicle to spin the wheels above 56 km/h (35 mph).
 - If you are still stuck after rocking the vehicle a few times, have the vehicle pulled out by a tow vehicle to avoid motor overheating, possible damage to the gear, and tire damage.
-

Smooth cornering

Avoid braking or gear changing in corners, especially when roads are wet. Ideally, corners should always be taken under gentle acceleration.

Driving at night

Night driving presents more hazards than driving in the daylight. Here are some important tips to remember:

- Slow down and keep more distance between you and other vehicles, as it may be more difficult to see at night, especially in areas where there may not be any street lights.
- Adjust your mirrors to reduce the glare from other drivers' headlights.
- Keep your headlights clean and properly aimed. Dirty or improperly aimed headlights will make it much more difficult to see at night.
- Avoid staring directly at the headlights of oncoming vehicles. You could be temporarily blinded, and it will take several seconds for your eyes to readjust to the darkness.

Driving in the rain

Rain and wet roads can make driving dangerous. Here are a few things to consider when driving in the rain or on slick pavement:

- Slow down and allow extra following distance. A heavy rainfall makes it harder to see and increases the distance needed to stop your vehicle.
- Turn OFF your Cruise Control. (if equipped)
- Replace your windscreen wiper blades when they show signs of streaking or missing areas on the windscreen.

- Be sure your tires have enough tread. If your tires do not have enough tread, making a quick stop on wet pavement can cause a skid and possibly lead to an accident.

For more information, refer to the "Tire replacement" section in chapter 9.

- Turn on your headlights to make it easier for others to see you.
- Driving too fast through large puddles can affect your brakes. If you must go through puddles, try to drive through them slowly.
- If you believe your brakes may be wet, apply them lightly while driving until normal braking operation returns.

Hydroplaning

If the road is wet enough and you are going fast enough, your vehicle may have little or no contact with the road surface and actually ride on the water. The best advice is SLOW DOWN when the road is wet.

The risk of hydroplaning increases as the depth of tire tread decreases, refer to the "Tire replacement" section in chapter 9.

Driving in flooded areas

Avoid driving through flooded areas unless you are sure the water is no higher than the bottom of the wheel hub. Drive through any water slowly. Allow adequate stopping distance because brake performance may be reduced.

After driving through water, dry the brakes by gently applying them several times while the vehicle is moving slowly.

Highway driving

Tires

Adjust the tire inflation, as specified. Under-inflation may overheat or damage the tires.

Do not install worn-out or damaged tires, which may reduce traction or fail.

i Information

Never over-inflate your tires above the maximum inflation pressure, as specified on your tires.

Coolant and high voltage battery

Driving at higher speeds on the highway consumes more electric energy and is less efficient than driving at a slower, more moderate speed. Maintain a moderate speed in order to conserve electric energy when driving on the highway.

Be sure to check both the coolant level and the electric energy level before driving.

Reducing the risk of rollover

Your multi-purpose passenger vehicle is defined as a Sports Utility Vehicle (SUV). Some SUVs have higher ground clearance and a narrower track to make them capable of performing in a wide variety of off-road applications. The specific design characteristics can give them a higher center of gravity than ordinary passenger vehicles making them more likely to roll over if you make abrupt turns. SUVs have a significantly higher rollover rate than other types of vehicles. Always make sure you and your passengers wear your seat belts properly and securely. In a rollover crash, an unbelted person is significantly more likely to be seriously injured or killed than a person wearing a seat belt.

There are steps that a driver can make to reduce the risk of a rollover. If at all possible, avoid sharp turns or abrupt maneuvers, do not load your vehicle with heavy cargo on the roof, and never modify your vehicle in any way.

⚠ WARNING

Some Sports Utility Vehicles (SUVs) can have a significantly higher rollover rate than other types of vehicles. To prevent rollovers or loss of control:

- Take corners at slower speeds than you would with a passenger vehicle.
 - Avoid sharp turns and abrupt maneuvers.
 - Do not modify your vehicle in any way that you would raise the center of gravity.
 - Keep tires properly inflated.
 - Do not carry heavy cargo on the roof.
-

⚠ WARNING

Fasten your seat belt properly. In a rollover crash, an unbelted person is significantly more likely to be seriously injured or killed than a person wearing a seat belt.

Winter driving

Snow or icy conditions

You need to keep sufficient distance between your vehicle and the vehicle in front of you.

Apply the brakes gently. Speeding, rapid acceleration, sudden brake applications, and sharp turns are very hazardous practices. Sudden brake applications on snowy or icy roads may cause the vehicle to skid.

To drive your vehicle in deep snow, it may be necessary to use snow tires or to install tire chains on your tires.

Always carry emergency equipment. You may want to carry tire chains, tow straps or chains, a flashlight, emergency flares, sand, a shovel, jumper cables, a window scraper, gloves, ground cloth, coveralls, a blanket, etc.

Snow tires

WARNING

Snow tires should be equivalent in size and type to the vehicle's standard tires. Otherwise, the safety and handling of your vehicle may be adversely affected.

Use snow tires when the road temperature is below 7 °C (45 °F). If you mount snow tires on your vehicle, be sure to use the same inflation pressure as the original tires. Mount snow tires on all four wheels to balance your vehicle's handling in all weather conditions.

The traction provided by snow tires on dry roads may not be as high as your vehicle's original equipment tires. Check with the tire dealer for maximum speed recommendations.

Tire chains

Wire chain



Fabric chain



Since the sidewalls of radial tires are thinner than other types of tires, they may be damaged by mounting some types of tire chains on them. Therefore, the use of snow tires is recommended instead of tire chains. If tire chains must be used, use only chains suitable for this vehicle and install the tire chains after reviewing the instructions provided with the tire chains. Damage to your vehicle caused by improper tire chain use is not covered by your vehicle manufacturer's warranty.

WARNING

The use of tire chains may adversely affect vehicle handling:

- Drive less than 30 km/h (20 mph) or the chain manufacturer's recommended speed limit, whichever is lower.
- Drive carefully and avoid bumps, holes, sharp turns, and other road hazards, which may cause the vehicle to bounce.

- Avoid sharp turns or locked wheel braking.
- Install tire chains only in pairs and on the front tires. Installing tire chains on the tires provides a greater driving force, but does not prevent side skids.

i Information

Do not install studded tires without first checking local and municipal regulations for possible restrictions against their use.

Chain Installation

When installing tire chains, follow the manufacturer's instructions and mount them as tightly possible. Drive slowly (less than 30 km/h (20 mph) or the chain manufacturer's recommended speed limit) with chains installed. If you hear the chains contacting the body or chassis, stop and tighten them. If they still make contact, slow down until the noise stops. Remove the tire chains as soon as you begin driving on cleared roads.

When mounting snow chains, park the vehicle on level ground away from traffic. Turn on the vehicle's Hazard Warning Flasher and place a triangular emergency warning device behind the vehicle (if available). Always place the vehicle in P (Park), apply the EPB, and turn off the vehicle before installing snow chains.

NOTICE

When using tire chains:

- Wrong size chains or improperly installed chains may damage your vehicle's brake lines, suspension, body, and wheels.
 - Use only chains suitable for this vehicle, such as SAE "S" class wire chains less than 12 mm (0.47 in.) thick or fabric chains. However, Do not use wire chains on 17 inch tires.
 - If you hear noise caused by chains contacting the body, retighten the chains to prevent contact with the vehicle body.
 - To prevent body damage, retighten the chains after driving 0.5-1.0 km (0.3-0.6 mi.).
 - Avoid using metal chains on aluminum wheels as this may damage the wheel.
-

Winter precautions

Check battery and cables

Winter temperatures may affect the battery performance. Inspect the battery and cables, as specified in Chapter 9. The battery charging level can be checked by an authorized HYUNDAI dealer or in a service station.

To prevent locks from freezing

Spray approved de-icing fluid or glycerin into key holes. When a lock opening is already covered with ice, spray approved de-icing fluid over the ice to remove it. When an internal part of a lock freezes, try to thaw it with a heated key. Carefully use the heated key to avoid an injury.

Use approved window washer antifreeze solution

Add window washer anti-freeze solution, as specified on the window washer container. Window washer anti-freeze solution is available from an authorized HYUNDAI dealer, and most vehicle accessory outlets.

Do not let your parking brake freeze

Under some conditions, your parking brake may freeze in the engaged position. This is most likely to happen when there is an accumulation of snow or ice around or near the rear brakes or the brakes are wet. When there is the risk that your parking brake may freeze: temporarily apply the parking brake with the gear in P (Park), then block the rear wheels, and then release the parking brake.

Do not let ice and snow accumulate underneath

Under some conditions, snow and ice may build up under the fenders and interfere with the steering. When driving in such conditions during the severe winter, check underneath the vehicle on a regular basis, to make sure that the front wheels and the steering components are not blocked.

Carry emergency equipment

In accordance with weather conditions, carry appropriate emergency equipment, while driving. Some of the items you may want to carry include tire chains, tow straps or chains, flashlight, emergency flares, sand, shovel, jumper cables, window scraper, gloves, ground cloth, coveralls, blanket, etc.

Do not place objects or materials in the motor compartment

Putting objects or materials in the motor compartment may cause an motor failure. Such damage is not covered by the manufacturer's warranty.

Trailer towing

We do not recommend using this vehicle for trailer towing.

Vehicle weight

Two labels on your driver's door sill show how much weight your vehicle was designed to carry: the Tire and Loading Information Label and the Certification Label.

Before loading your vehicle, familiarize yourself with the following terms for determining your vehicle's weight ratings, from the vehicle's specifications and the Certification Label:

Base Curb Weight

This is the weight of the vehicle including high voltage battery and all standard equipment. It does not include passengers, cargo, or optional equipment.

Vehicle Curb Weight

This is the weight of your new vehicle when you picked it up from your dealer plus any aftermarket equipment.

Cargo Weight

This figure includes all weight added to the Base Curb Weight, including cargo and optional equipment.

GAW (Gross Axle Weight)

This is the total weight placed on each axle (front and rear) - including vehicle curb weight and all payload.

GAWR (Gross Axle Weight Rating)

This is the maximum allowable weight that can be carried by a single axle (front or rear). These numbers are shown on the Certification Label. The total load on each axle must never exceed its GAWR.

GVW (Gross Vehicle Weight)

This is the Base Curb Weight plus actual Cargo Weight plus passengers.

GVWR (Gross Vehicle Weight Rating)

This is the maximum allowable weight of the fully loaded vehicle (including all options, equipment, passengers and cargo). The GVWR is shown on the Certification Label located on the driver's door sill.

Overloading

WARNING

The Gross Axle Weight Rating (GAWR) and the Gross Vehicle Weight Rating (GVWR) for your vehicle are on the Certification Label attached to the driver's (or front passenger's) door. Exceeding these ratings can cause an accident or vehicle damage. You can calculate the weight of your load by weighing the items (and people) before putting them in the vehicle. Be careful not to overload your vehicle.

7. Driver assistance system

Driver assistance system notice.....	7-4
Forward Collision-Avoidance Assist (FCA) (Front view camera only)	7-4
Forward Collision-Avoidance Assist settings.....	7-5
Forward Collision-Avoidance Assist operation.....	7-7
Forward Collision-Avoidance Assist malfunction and limitations.....	7-10
Forward Collision-Avoidance Assist (FCA) (Sensor fusion)	7-17
Forward Collision-Avoidance Assist settings.....	7-19
Forward Collision-Avoidance Assist operation.....	7-20
Forward Collision-Avoidance Assist malfunction and limitations.....	7-27
Lane Keeping Assist (LKA).....	7-34
Lane Keeping Assist settings.....	7-35
Lane Keeping Assist operation.....	7-36
Lane Keeping Assist malfunction and limitations	7-39
Blind-Spot Collision-Avoidance Assist (BCA)	7-42
Blind-Spot Collision-Avoidance Assist settings.....	7-44
Blind-Spot Collision-Avoidance Assist operation.....	7-45
Blind-Spot Collision-Avoidance Assist malfunction and limitations.....	7-48
Safe Exit Warning (SEW)	7-54
Safe Exit Warning settings	7-55
Safe Exit Warning operation.....	7-56
Safe Exit Warning malfunction and limitations	7-57
Manual Speed Limit Assist (MSLA).....	7-59
Manual Speed Limit Assist operation	7-60
Intelligent Speed Limit Assist (ISLA)	7-62
Intelligent Speed Limit Assist Settings.....	7-63
Intelligent Speed Limit Assist Operation.....	7-65
Intelligent Speed Limit Assist Malfunction and Limitations	7-67
Driver Attention Warning (DAW)	7-70
Driver Attention Warning settings	7-71
Driver Attention Warning operation	7-71
Driver Attention Warning malfunction and limitations.....	7-73
Forward Attention Warning (FAW)	7-76
Forward Attention Warning settings	7-77
Forward Attention Warning operation	7-77
Forward Attention Warning malfunction and limitations	7-79

Blind-Spot View Monitor (BVM).....	7-81
Blind-Spot View Monitor settings	7-82
Blind-Spot View Monitor operation	7-82
Blind-Spot View Monitor malfunction	7-83
Cruise Control (CC).....	7-83
Cruise Control operation	7-83
Smart Cruise Control (SCC).....	7-87
Smart Cruise Control settings	7-87
Smart Cruise Control operation	7-89
Smart Cruise Control malfunction and limitations	7-98
Navigation-Based Smart Cruise Control (NSCC).....	7-103
Navigation-based Smart Cruise Control Settings.....	7-104
Navigation-based Smart Cruise Control Operation.....	7-104
Limitations of Navigation-based Smart Cruise Control	7-106
Lane Following Assist (LFA).....	7-109
Lane Following Assist settings	7-109
Lane Following Assist operation	7-110
Lane Following Assist malfunction and limitations	7-112
Highway Driving Assist (HDA).....	7-113
Highway Driving Assist Settings.....	7-114
Highway Driving Assist Operation	7-115
Highway Driving Assist Malfunction and Limitations	7-118
Rear View Monitor (RVM).....	7-120
Rear View Monitor settings	7-120
Rear View Monitor operation	7-122
Rear View Monitor malfunction and limitations	7-123
Surround View Monitor (SVM)	7-124
Surround View Monitor settings	7-125
Surround View Monitor operation.....	7-126
Surround View Monitor malfunction and limitations	7-129
Rear Cross-Traffic Collision-Avoidance Assist (RCCA)	7-130
Rear Cross-Traffic Collision-Avoidance Assist settings.....	7-131
Rear Cross-Traffic Collision-Avoidance Assist operation.....	7-132
Rear Cross-Traffic Collision-Avoidance Assist malfunction and limitations	7-135
Reverse Parking Distance Warning (PDW).....	7-140

7. Driver assistance system

Reverse Parking Distance Warning settings	7-140
Reverse Parking Distance Warning operation	7-142
Reverse Parking Distance Warning malfunction and limitations	7-142
Forward/Reverse Parking Distance Warning (PDW).....	7-144
Forward/Reverse Parking Distance Warning settings	7-145
Forward/Reverse Parking Distance Warning operation	7-146
Forward/Reverse Parking Distance Warning malfunction and limitations	7-148
Reverse Parking Collision-Avoidance Assist (PCA)	7-150
Reverse Parking Collision-Avoidance Assist settings	7-150
Reverse Parking Collision-Avoidance Assist operation.....	7-151
Reverse Parking Collision-Avoidance Assist malfunction and limitations	7-153
Declaration of conformity.....	7-157
Front radar.....	7-157
Rear corner radar	7-159

Driver assistance system notice

i Information

Due to the infotainment software version, the description of each function of the driver assistance system may differ from the owner's manual.

If an infotainment system (genuine Hyundai part) has been installed, familiarize yourself with its settings and functions as outlined in the web manual, which can be accessed via the QR code in the Infotainment System Quick Guide.

Forward Collision-Avoidance Assist (FCA) (Front view camera only)

+ If equipped

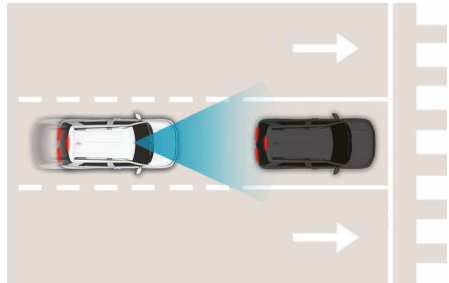

Forward Collision-Avoidance Assist is designed to help detect and monitor the vehicle ahead or help detect a motorcyclist, pedestrian or cyclist in the roadway and warn the driver that a collision is imminent with a warning message and warning and apply emergency braking.

NOTICE

A motorcyclist refers to the driver of a vehicle riding the following powered two-wheeler.

- Mopeds with 50 cc and restricted top speeds
 - Motorcycles
-

Detecting sensor



(1) Front view camera

Refer to the picture above for the detailed location of the detecting sensor.

CAUTION

Take the following precautions to maintain optimal performance of the detecting sensor:

- Never disassemble the detecting sensor or sensor assembly, or cause any damage to it.
- If the detecting sensor have been replaced or repaired, we recommend that you have your vehicle inspected by an authorized HYUNDAI dealer.
- Never install any accessories or stickers on the front windshield, or tint the front windshield.
- Pay extreme caution to keep the front view camera dry.
- Never place any reflective objects (for example, white paper, mirror) over the dashboard.
- Do not place any objects near the front windshield or install any accessories on the front windshield. It can affect the performance of the defogging and defrosting function of the climate control system, which may prevent the Driver Assistance systems from operating.

Forward Collision-Avoidance Assist settings

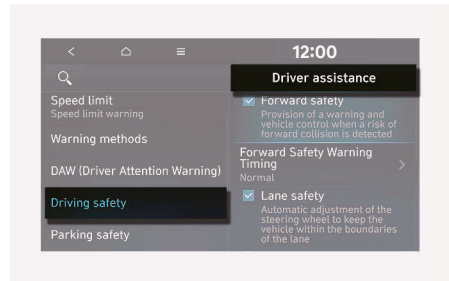

Forward safety

With the vehicle on, select **User Settings > Driver Assistance > Driving Safety** in the instrument cluster or **Settings > Vehicle > Driver assistance > Driving safety** in the infotainment system to set whether to use each function.

- If **Forward safety** is selected, Forward Collision-Avoidance Assist will warn the driver with a warning message, an audible warning depending on the collision risk levels. Braking assist will be applied depending on the collision risk levels. If **Forward safety** is deselected, Forward Safety will turn off. The warning light (⚠) will illuminate on the cluster.

 **WARNING**

When the vehicle is restarted, Forward Collision-Avoidance Assist will always turn on. However, if **Forward safety** is deselected, the driver should always be aware of the surroundings and drive safely.

The driver can monitor Forward Collision-Avoidance Assist selected/deselected status from the Settings menu. If the warning light (⚠) remains ON when Forward Collision-Avoidance Assist is on, have the vehicle inspected by an authorized HYUNDAI dealer.

 **WARNING**

When the vehicle is restarted, Forward Collision-Avoidance Assist will always turn on. However, if **Forward safety** is deselected the driver should always be aware of the surroundings and drive safely.

Forward Safety Warning Timing

With the vehicle on, select **User settings > Driver Assistance > Driving Safety > Forward Safety Warning Timing** in the instrument cluster or **Settings > Vehicle > Driver assistance > Driving safety > Forward Safety Warning Timing** in the infotainment system to change the initial warning activation time for Forward Collision-Avoidance Assist. The warning time can be set to either **Normal** or **Late**.

- Use **Normal** in normal driving conditions. If the Warning Timing seems sensitive, change it to **Late**.
 - If **Late** is selected, Forward Collision-Avoidance Assist, warns the driver more slowly.

 **CAUTION**

- Even though **Normal** is selected for Warning Timing, if the front vehicle suddenly stops, the warning may seem late.
 - Select **Late** for Warning Timing when traffic is light and when driving speed is slow.
-

Warning methods

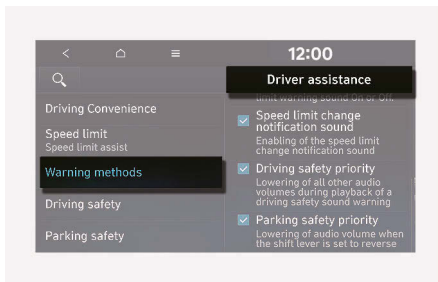
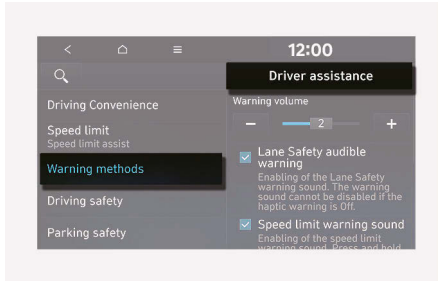

With the vehicle on, select **User Settings** > **Driver Assistance** > **Warning Methods** > **Warning Volume** on the instrument cluster or **Settings** > **Vehicle** > **Driver assistance** > **Warning methods** in the infotainment system to select following:

- **Warning volume:** The warning volume can be adjusted.
- **Driving safety priority:** Your vehicle lowers all other audio volumes when the Driver Assistance system warning sounds.

i Information

- If you change the Warning methods, the Warning methods of other Driver Assistance systems may change.
- Warning methods will maintain its last setting even if the vehicle is restarted.
- The setting menu may not be available for your vehicle depending on the vehicle features and specifications.

Forward Collision-Avoidance Assist operation

Basic function

The basic function for Forward Collision-Avoidance Assist is to warn and help control the vehicle depending on the collision risk level: 'Collision Warning', 'Emergency Braking' and 'Stopping vehicle and ending brake control'.



Collision Warning

- To warn the driver of a collision, the "**Collision Warning**" warning message will appear on the cluster display, an audible warning will sound.
- If a vehicle or motorcyclist is detected in front, the function will operate when your vehicle speed is between about 10-180 km/h (6-112 mph).
- If a pedestrian or cyclist is detected in front, the function will operate when your vehicle speed is between about 10-80 km/h (6-50 mph).

Emergency Braking

To warn the driver that emergency braking will be assisted, the "**Emergency Braking**" warning message will appear on the cluster display, an audible warning will sound.

Emergency braking will operate under the following conditions.

- Vehicle or motorcyclist:

	Driving vehicle	Stopped vehicle
Strong braking power	About 10-130 km/h (6-80 mph)	About 10-60 km/h (6-37 mph)

- Pedestrian or cyclist:

The function will operate when your vehicle speed is between about 10-60 km/h (6-37 mph).

⚠ CAUTION

- The function operation range may decrease due to the front traffic condition or the surroundings of the vehicle.
- When driving at night, the motorcyclist recognition performance is degraded, so Forward Collision-Avoidance Assist may be temporarily limited or may not work.

Stopping vehicle and ending brake control



- When the vehicle is stopped due to emergency braking, the "**Drive carefully**" warning message will appear on the cluster.

For your safety, the driver should depress the brake pedal immediately and check the surroundings.

- Brake control will end after the vehicle is stopped by emergency braking for about 2 seconds.

i Information

Press the hazard warning flasher to turn off the audible warning of the collision warning or emergency braking system.

! WARNING

- For your safety, only change the Settings after parking the vehicle at a safe location.
- Forward Collision-Avoidance Assist does not operate in all situations and cannot avoid all collisions.
- The driver has the responsibility to control the vehicle. Do not solely depend on Forward Collision-Avoidance Assist. Rather, maintain a safe braking distance, and if necessary, depress the brake pedal to reduce driving speed or to stop the vehicle.
- Never deliberately operate Forward Collision-Avoidance Assist on people, objects, etc. It may cause serious injury or death.
- Forward Collision-Avoidance Assist may not operate if the driver depresses the brake pedal to avoid collision.
- During Forward Collision-Avoidance Assist operation, the vehicle may stop suddenly injuring passengers and shifting loose objects. Always have the seat belt on and keep loose objects secured.
- If any other system's warning message appears or audible warning is generated, Forward Collision-Avoidance Assist warning message may not be displayed and audible warning may not be generated.

- You may not hear the warning sound of Forward Collision-Avoidance Assist if the surrounding is noisy.
 - Forward Collision-Avoidance Assist may turn off or may not operate properly or may operate unnecessarily depending on the road conditions and the surroundings.
 - Even if there is a problem with Forward Collision-Avoidance Assist, the vehicle's basic braking performance will operate properly.
 - During emergency braking, braking control by Forward Collision-Avoidance Assist will automatically cancel when the driver excessively depresses the accelerator pedal or sharply steers the vehicle.
-

! CAUTION

- Depending on the condition of the Vehicle or motorcycle, pedestrian and cyclist in front and the surroundings, the speed range to operate Forward Collision-Avoidance Assist may reduce. Forward Collision-Avoidance Assist may only warn the driver, or it may not operate.
 - Forward Collision-Avoidance Assist will operate under certain conditions by judging the risk level based on the condition of the oncoming vehicle or motorcyclist driving direction, speed and surroundings.
 - Only Forward Collision-Avoidance Assist warning and collision mitigation are possible depending on the detectable distance.
-



i Information

- In a situation where collision is imminent, braking may be assisted by Forward Collision-Avoidance Assist when braking is insufficient by the driver.
- The images and colors in the instrument cluster may differ depending on the cluster type or theme selected from the settings menu.

Forward Collision-Avoidance Assist malfunction and limitations

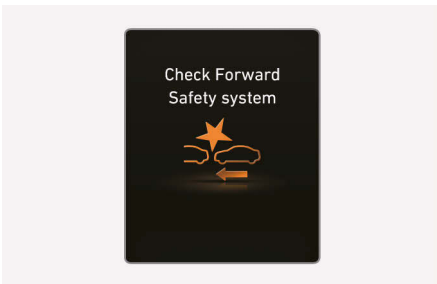
Forward Collision-Avoidance Assist malfunction





When Forward Collision-Avoidance Assist is not working properly, the "**Check Forward Safety system**" warning message will appear, and the  and  warning lights will illuminate on the cluster display. We recommend that the vehicle be inspected by an authorized HYUNDAI dealer.

Forward Collision-Avoidance Assist disabled



When the front windshield where the front view camera is located or the sensor is covered with foreign material, such as snow or rain, it can reduce the detecting performance and temporarily limit or disable Forward Collision-Avoidance Assist.

If this occurs the "**Forward Safety system disabled. Camera obscured.**" warning message, and the  and  warning lights will illuminate on the cluster display.

Forward Collision-Avoidance Assist will operate properly when such snow, rain or foreign material is removed.

If Forward Collision-Avoidance Assist does not operate properly after obstruction (snow, rain, or foreign material) is removed, we recommend that the vehicle be inspected by an authorized HYUNDAI dealer.

⚠ WARNING

- Even though the warning message or warning light does not appear on the cluster display, Forward Collision-Avoidance Assist may not properly operate.
 - Forward Collision-Avoidance Assist may not properly operate in an area (for example, open terrain), where any objects are not detected after turning ON the vehicle.
 - If the vehicle is turned off and restarted while the camera is blocked or malfunctioned, the condition is maintained. Therefore, Forward Collision-Avoidance Assist may not operate properly.
-

Limitations of Forward Collision-Avoidance Assist

Forward Collision-Avoidance Assist may not operate properly, or it may operate unexpectedly under the following circumstances:

- The detecting sensor or the surroundings are contaminated or damaged
- The temperature around the front view camera is high or low due to surrounding environment
- The camera lens is contaminated due to tinted, filmed or coated windshield, damaged glass, or sticky foreign material (sticker, bug, etc.) on the glass
- Moisture is not removed or frozen on the windshield
- Washer fluid is continuously sprayed, or the wiper is on
- Driving in heavy rain or snow, or thick fog
- The field of view of the front view camera is obstructed by sun glare
- Street light or light from an oncoming traffic is reflected on the wet road surface, such as a puddle on the road
- An object is placed on the dashboard
- Your vehicle is being towed
- The surrounding is very bright
- The surrounding is very dark, such as in a tunnel, etc.
- The brightness changes suddenly, for example when entering or exiting a tunnel
- The brightness outside is low, and the headlamps are not on or are not bright

- Driving through steam, smoke or shadow
- Only part of the vehicle, motorcyclist, pedestrian or cyclist is detected
- The vehicle in front is a bus, heavy truck, truck with an unusually shaped cargo, trailer, etc.
- The vehicle in front has no tail lights, tail lights are located unusually, etc.
- The brightness outside is low, and the tail lamps are not on or are not bright
- The rear of the front vehicle is small or the vehicle does not look normal, such as when the vehicle is tilted, overturned, or the side of the vehicle is visible, etc.
- The front vehicle's ground clearance is low or high
- A vehicle, motorcyclist, pedestrian or cyclist suddenly cuts in front
- The vehicle or motorcyclist in front is detected late
- The vehicle or motorcyclist in front is suddenly blocked by an obstacle
- The vehicle or motorcyclist in front suddenly changes lane or suddenly reduces speed
- The vehicle or motorcyclist in front is bent out of shape
- The vehicle or motorcyclist in front is covered with snow
- You are departing or returning to the lane
- Unstable driving
- You are on a roundabout and the vehicle in front is not detected
- You are continuously driving in a circle

- The vehicle or motorcyclist in front has an unusual shape
- The vehicle or motorcyclist in front is driving uphill or downhill
- The pedestrian or cyclist is not fully detected, for example, if the pedestrian is leaning over or is not fully walking upright
- The pedestrian or cyclist is wearing clothing or equipment that makes it difficult to detect as a pedestrian or cyclist



The illustration above shows the image the front view camera capable of detecting as a vehicle, motorcyclist, pedestrian and cyclist.

- The pedestrian or cyclist in front is moving very quickly
- The pedestrian or cyclist in front is short or is posing a low posture
- The pedestrian or cyclist in front has impaired mobility
- The pedestrian or cyclist in front is moving intersected with the driving direction
- There is a group of pedestrians, cyclists or a large crowd in front

- The pedestrian or cyclist is wearing clothing that easily blends into the background, making it difficult to detect
- The pedestrian or cyclist is difficult to distinguish from the similarly shaped structure in the surroundings
- You are driving by a pedestrian, cyclist, traffic signs, structures, etc., near the intersection
- Driving in a parking lot
- Driving through a tollgate, construction area, unpaved road, partial paved road, uneven road, speed bumps, etc.
- Driving on an incline road, curved road, etc.
- Driving through a roadside with trees or streetlights
- The adverse road conditions cause excessive vehicle vibrations while driving
- Your vehicle height is low or high due to heavy loads, abnormal tire pressure, etc.
- Driving through a narrow road where trees or grass are overgrown
- There is interference by electromagnetic waves, such as driving in an area with strong radio waves or electrical noise
- The vehicle is installed with a snow chain, spare tire or different size wheel.

WARNING

- **Driving on a curved road**

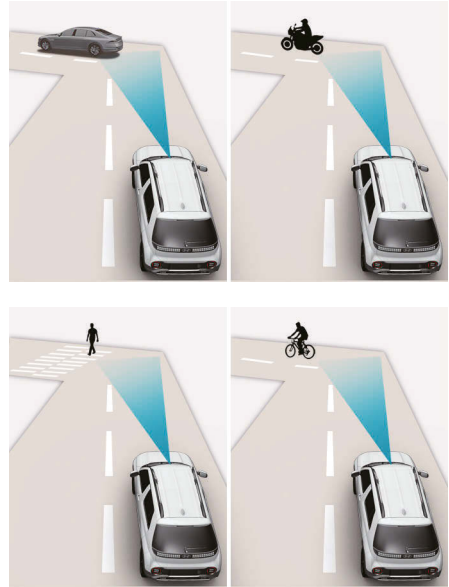

Forward Collision-Avoidance Assist may not detect other a vehicle, a motorcyclist, a pedestrian or a cyclist front of you when driving on curved roads adversely affecting the performance of the sensors. This may result in no warning or braking assist when necessary.

When driving on a curved road, you must maintain a safe braking distance, and if necessary, steer the vehicle and depress the brake pedal to reduce your driving speed in order to maintain a safe distance.

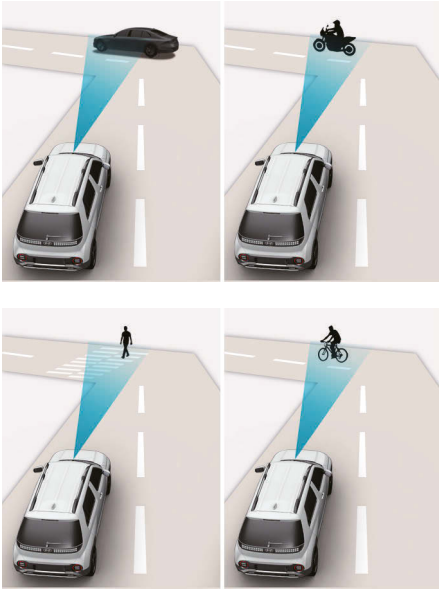

Forward Collision-Avoidance Assist may detect a vehicle, a motorcyclist, a pedestrian or a cyclist in the next lane or outside the lane when driving on a curved road.

If this occurs, Forward Collision-Avoidance Assist may unnecessarily warn the driver and control the brake. Always check the traffic conditions around the vehicle.

• Driving on an inclined road

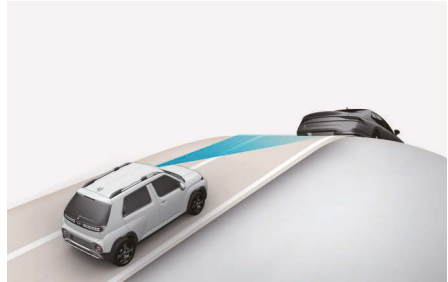

Forward Collision-Avoidance Assist may not detect other a vehicle, a motorcyclist, a pedestrian or a cyclist in front of you while driving uphill or downhill, adversely affecting the performance of the sensors.

This may result in unnecessary warning, braking assist or no warning, braking assist when necessary.

Also, vehicle speed may rapidly decrease when a vehicle, motorcyclist, pedestrian or cyclist ahead is suddenly detected.

Always have your eyes on the road while driving uphill or downhill and if necessary, steer the vehicle and depress the brake pedal to reduce your driving speed in order to maintain a safe distance.

• Changing lanes

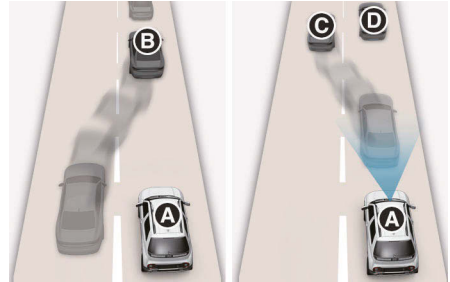

- [A] Your vehicle
- [B] Lane changing vehicle
- [C] Same lane vehicle or motorcyclist
- [D] Lane changing vehicle

When a vehicle moves into your lane from an adjacent lane, it cannot be detected by the sensor until it is in the sensor's detection range. Forward Collision-Avoidance Assist may not immediately detect the vehicle when the vehicle changes lanes abruptly. In this case, you must maintain a safe braking distance, and if necessary, steer the vehicle and depress the brake pedal to reduce your driving speed in order to maintain a safe distance.

When a vehicle in front of you lane change to the next lane, Forward Collision-Avoidance Assist may not immediately detect the vehicle or motorcyclist that is now in front of you.

In this case, you must maintain a safe braking distance, and if necessary, steer the vehicle and depress the brake pedal to reduce your driving speed in order to maintain a safe distance.

• Detecting vehicle

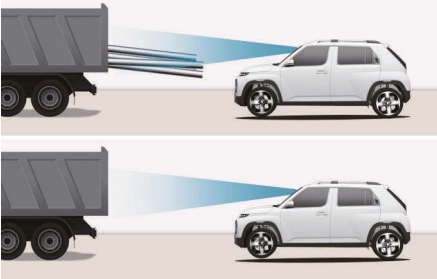

If the vehicle in front of you has cargo that extends rearward from the cab, or when the vehicle in front of you has higher ground clearance, additional special attention is required. Forward Collision-Avoidance Assist may not be able to detect the cargo extending from the vehicle. In these instances, you must maintain a safe braking distance from the rearmost object, and if necessary, steer the vehicle and depress the brake pedal to reduce your driving speed in order to maintain distance.

WARNING

- When you are towing a trailer or another vehicle, turn off Forward Collision-Avoidance Assist for safety reasons.
 - Forward Collision-Avoidance Assist may operate if objects that are similar in shape or characteristics to a vehicle, a motorcyclist, a pedestrian and a cyclists is detected.
 - Forward Collision-Avoidance Assist does not recognize carts, bicycles, suitcases, strollers, etc. pulled or pushed by a pedestrian or a cyclist..
 - Forward Collision-Avoidance Assist may not operate properly if interfered by strong electromagnetic waves.
 - Forward Collision-Avoidance Assist may not operate for 15 seconds after the vehicle is started, or the front view camera is initialized.
-

Forward Collision-Avoidance Assist (FCA) (Sensor fusion)

 if equipped

Basic function

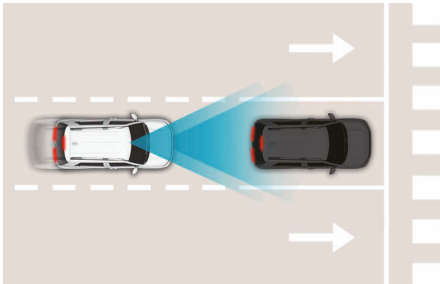

Forward Collision-Avoidance Assist detects a vehicle, a motorcyclist, a pedestrian, or a cyclist ahead on the road and may warn you of a possible collision with a warning message on the instrument cluster and a warning sound. Also, Forward Collision-Avoidance Assist may assist with braking your vehicle to help reduce collision speed or avoid a collision.

NOTICE

A motorcyclist refers to the driver of a vehicle riding the following powered two-wheeler.

- Mopeds with 50 cc and restricted top speeds
- Motorcycles

Junction Turning function

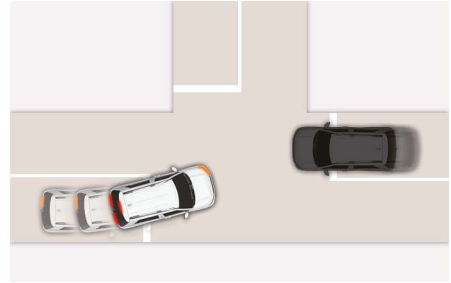

Junction Turning function can help avoid a collision with an oncoming vehicle or motorcyclist in an adjacent lane when turning left (left-hand drive) or right (right-hand drive) at a crossroad with the turn signal on by applying emergency braking.

Direct Oncoming function

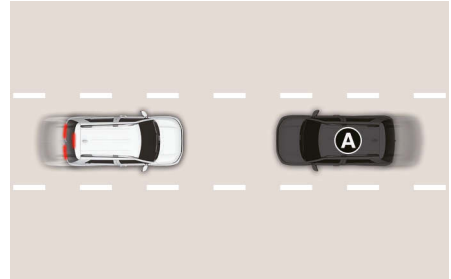

[A] Oncoming vehicle

Direct Oncoming function helps reduce the speed at the collision when a vehicle or motorcyclist approaching from the opposite side is detected.

Detecting sensor

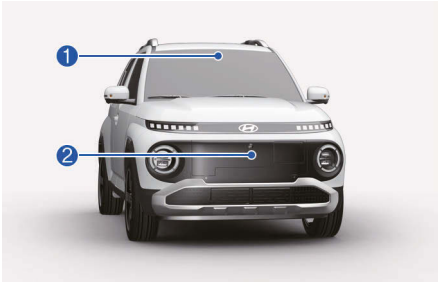

- (1) Front view camera
- (2) Front radar

Refer to the picture above for the detailed location of the detecting sensors.

CAUTION

Take the following precautions to maintain optimal performance of the detecting sensor:

- Never disassemble the detecting sensor or sensor assembly, or cause any damage to it.
 - If the detecting sensors have been replaced or repaired, we recommend that your vehicle be inspected by an authorized HYUNDAI dealer.
 - Never install any accessories or stickers on the front windshield, or tint the front windshield.
 - Exercise extreme caution to keep the front view camera dry.
 - Never place any reflective objects (for example, white paper, mirror) over the dashboard.
 - Do not place any objects near the front windshield or install any accessories on the front windshield. It can affect the performance of the defogging and defrosting function of the climate control system, which may prevent the Driver Assistance systems from operating.
- Do not apply license plate frame or objects, such as a bumper sticker, film or a bumper guard, near the front radar cover.
 - Do not change the position of the license plate. The front radar's detection and control performance may be affected.
 - Always keep the front radar and cover clean and free of dirt and debris.
Use only a soft cloth to wash the vehicle. Do not spray pressurized water directly on the sensor or sensor cover.
 - If the radar or around the radar has been damaged or impacted in any way, Forward Collision-Avoidance Assist may not properly operate even though a warning message does not appear on the cluster. we recommend that your vehicle be inspected by an authorized HYUNDAI dealer.
 - Use only genuine parts to repair or replace a damaged front radar cover. Do not apply paint to the front radar cover.
 - Vehicles equipped with radar
 - The function may not work properly when the bumper has been replaced, or the surroundings of the radar has been damaged or paint has been applied.
 - If a trailer, carrier, etc., is installed, it may adversely affect the performance of the radar or Forward Collision-Avoidance Assist may not operate properly.

Forward Collision-Avoidance Assist settings

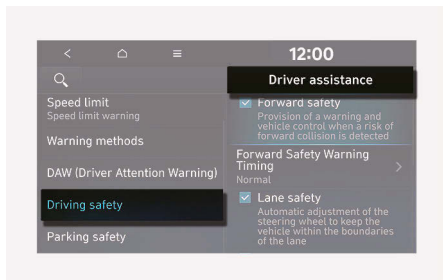

Forward safety

With the vehicle on, select **User Settings** > **Driver Assistance** > **Driving Safety** in the instrument cluster or **Settings** > **Vehicle** > **Driver assistance** > **Driving safety** in the infotainment system to set whether to use each function.

- If **Forward safety** is selected, Forward Collision-Avoidance Assist will warn the driver with a warning message, an audible warning depending on the collision risk levels. Braking assist will be applied depending on the collision risk levels. If **Forward safety** is deselected, Forward Safety will turn off. The warning light (⚠) will illuminate on the cluster.

⚠ WARNING

When the vehicle is restarted, Forward Collision-Avoidance Assist will always turn on. However, if **Forward safety** is deselected, the driver should always be aware of the surroundings and drive safely.

⚠ CAUTION

The setting for **Forward safety** includes 'Basic function', 'Junction Turning', and 'Direct Oncoming'.

Forward Safety Warning Timing

With the vehicle on, select **User Settings** > **Driver Assistance** > **Driving Safety** > **Forward Safety Warning Timing** in the instrument cluster or **Settings** > **Vehicle** > **Driver assistance** > **Driving safety** > **Forward Safety Warning Timing** in the infotainment system to change the initial warning activation time for Forward Collision-Avoidance Assist. The warning time can be set to either **Normal** or **Late**.

- Use **Normal** in normal driving conditions. If the Warning Timing seems sensitive, change it to **Late**.
 - If **Late** is selected, Forward Collision-Avoidance Assist, warns the driver more slowly.

⚠ CAUTION

- Even though **Normal** is selected for Warning Timing, if the front vehicle suddenly stops, the warning may seem late.
- Select **Late** for warning timing when traffic is light and when driving speed is slow.

Warning methods

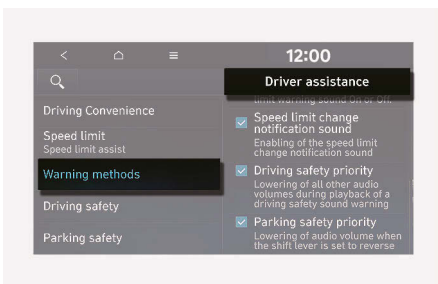
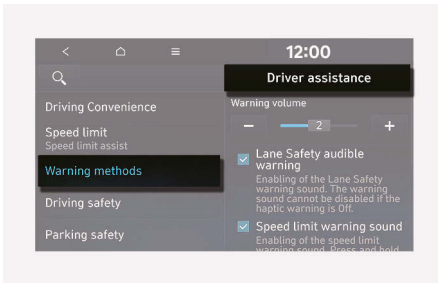

With the vehicle on, select **User Settings > Driver Assistance > Warning Methods > Warning Volume** on the instrument cluster or **Settings > Vehicle > Driver assistance > Warning methods** in the infotainment system to select following:

- **Warning volume:** The warning volume can be adjusted.
- **Driving safety priority:** Your vehicle lowers all other audio volumes when the Driver Assistance system warning sounds.

i Information

- If you change the Warning methods, the Warning methods of other Driver Assistance systems may change.
- Warning methods will maintain its last setting even if the vehicle is restarted.
- The setting menu may not be available for your vehicle depending on the vehicle features and specifications.

Forward Collision-Avoidance Assist operation

Basic function

The basic function for Forward Collision-Avoidance Assist is to warn and help control the vehicle depending on the collision risk level: 'Collision Warning', 'Emergency Braking' and 'Stopping vehicle and ending brake control'.



Collision Warning

- To warn the driver of a collision, the "**Collision Warning**" warning message will appear on the cluster, an audible warning will sound.
- If a vehicle or motorcyclist is detected in front, the function will operate when your vehicle speed is between about 10-200 km/h (6-124 mph).
- If a pedestrian or cyclist is detected in front, the function will operate when your vehicle speed is between about 10-65 km/h (6-40 mph).

Emergency Braking

To warn the driver that emergency braking will be assisted, the "**Emergency Braking**" warning message will appear on the cluster, an audible warning will sound.

Emergency braking will operate under the following conditions.

- Vehicle or motorcyclist:

	Driving vehicle	Stopped vehicle
Weak braking power	About 10-200 km/h (6-124 mph)	
Strong braking power	About 10-130 km/h (6-80 mph)	About 10-85 km/h (6-53 mph)

- Pedestrian or cyclist:

The function will operate when your vehicle speed is between about 10-85 km/h (6-53 mph).

CAUTION

The function operation range may decrease due to the front traffic condition or the surroundings of the vehicle.

When driving at night, the motorcyclist recognition performance is degraded, so Forward Collision-Avoidance Assist may be temporarily limited or may not work.

Stopping vehicle and ending brake control



- When the vehicle is stopped due to emergency braking, the "**Drive carefully**" warning message will appear on the cluster.

For your safety, the driver should depress the brake pedal immediately and check the surroundings.

- Brake control will end after the vehicle is stopped by emergency braking for about 2 seconds.

i Information

The audible warning can be turned off while collision warning or emergency braking is operating by pressing the hazard warning flasher button.

Junction Turning function

Junction Turning function will warn and help control the vehicle depending on the collision risk level: 'Collision Warning', 'Emergency Braking' and 'Stopping vehicle and ending brake control'.

Collision Warning



- To warn the driver of a collision, the "**Collision Warning**" warning message will appear on the cluster, an audible warning will sound.
- The function will operate when your vehicle speed is between about 10-30 km/h (6-19 mph) and the oncoming vehicle speed is between about 30-70 km/h (19-44 mph), motorcyclist and cyclist speed is between about 15-70 km/h (9-44 mph).

Emergency Braking



- To warn the driver that emergency braking will be assisted, the "**Emergency Braking**" warning message will appear on the cluster, an audible warning will sound.
- In emergency braking situation, braking is assisted with strong braking power by the function to help prevent collision with the oncoming vehicle.
- The function will operate when your vehicle speed is between about 10-30 km/h (6-19 mph) and the oncoming vehicle speed is between about 30-70 km/h (19-44 mph), motorcyclist and cyclist speed is between about 15-70 km/h (9-44 mph).

i Information

- If the driver's seat is on the left side, Junction Turning function will operate only for oncoming vehicles when you turn left. If the driver's seat position is on the right side, the function will operate only for oncoming vehicles when you turn right.
- When turning left (left-hand drive) or right (right-hand drive) at an intersection, braking is assisted to reduce or avoid collisions if there is a collision risk with a cyclist approaching at the speed of 15 to 20 km/h (9 to 12 mph) from the opposite side.

Stopping vehicle and ending brake control



- When the vehicle is stopped due to emergency braking, the "**Drive carefully**" warning message will appear on the cluster.

For your safety, the driver should depress the brake pedal immediately and check the surroundings.

- Brake control will end after the vehicle is stopped by emergency braking for about 2 seconds.

i Information

When a collision warning is being issued or emergency braking is being engaged, press the hazard warning flasher button to turn off the warning sound.

Direct-Oncoming function

Direct Oncoming function will warn and control the vehicle depending on the collision risk level: 'Collision Warning', 'Emergency Braking' and 'Stopping vehicle and ending brake control'.



Collision Warning

- To warn the driver of a collision, Forward Safety warning light (🚦) blinking, the **"Collision Warning"** warning message will appear on the instrument cluster, an audible warning will sound and the steering wheel will vibrate.
- The function will operate when your vehicle speed is between about 30-130 km/h (19-80 mph) the detected oncoming vehicle or the oncoming motorcyclist speed is about above 10 km/h (6 mph).

Emergency Braking

- To warn the driver that emergency braking will be assisted, Forward Safety warning light (🚦) blinking, the **'Emergency Braking'** warning message will appear on the instrument cluster, an audible warning will sound and the steering wheel will vibrate.
- In emergency braking situation, braking is assisted with strong braking power by the function to help prevent collision with the oncoming vehicle.
- The function will operate when your vehicle speed is between about 30-130 km/h (19-80 mph) and the detected oncoming vehicle or the oncoming motorcyclist speed is about above 10 km/h (6 mph).

Stopping vehicle and ending brake control



- When the vehicle is stopped due to emergency braking, the **"Drive carefully"** warning message will appear on the instrument cluster. For your safety, the driver should depress the brake pedal immediately and check the surroundings.
- Brake control will end after the vehicle is stopped by emergency braking for about 2 seconds.

⚠ CAUTION

If your vehicle or the oncoming vehicle or the oncoming motorcyclist is not driving straight, Direct Oncoming function warning and control may be late or may not operate.

⚠ WARNING

When driving at night, the motorcyclist recognition performance is degraded, so Forward Collision-Avoidance Assist may be temporarily limited or may not work.

***i* Information**

Press the hazard warning flasher to turn off the audible warning of the collision warning or emergency braking system.

⚠ WARNING

Take the following precautions when using Forward Collision-Avoidance Assist:

- For your safety, only change the Settings after parking the vehicle at a safe location.
- Forward Collision-Avoidance Assist does not operate in all situations and cannot avoid all collisions.
- The driver has the responsibility to control the vehicle. Do not solely depend on Forward Collision-Avoidance Assist. Rather, maintain a safe braking distance, and if necessary, depress the brake pedal to reduce driving speed or to stop the vehicle.
- Never deliberately operate Forward Collision-Avoidance Assist on people, objects, etc. It may cause serious injury or death.
- Forward Collision-Avoidance Assist may not operate if the driver depresses the brake pedal to avoid collision.
- Depending on the road and driving conditions, Forward Collision-Avoidance Assist may warn the driver late or may not warn the driver.
- During Forward Collision-Avoidance Assist operation, the vehicle may stop suddenly injuring passengers and shifting loose objects. Always have the seat belt on and keep loose objects secured.

- If any other system's warning message appears or audible warning is generated, Forward Collision-Avoidance Assist warning message may not be displayed and audible warning may not be generated.
 - You may not hear the warning sound of Forward Collision-Avoidance Assist if the surrounding is noisy.
 - Forward Collision-Avoidance Assist may turn off or may not operate properly or may operate unnecessarily depending on the road conditions and the surroundings.
 - Even if there is a problem with Forward Collision-Avoidance Assist, the vehicle's basic braking performance will operate properly.
 - During emergency braking, braking control by Forward Collision-Avoidance Assist will automatically cancel when the driver excessively depresses the accelerator pedal or sharply steers the vehicle.
-

CAUTION

- Depending on the condition of the vehicle, motorcyclist, pedestrian and cyclist in front and the surroundings, the speed range to operate Forward Collision-Avoidance Assist may reduce. Forward Collision-Avoidance Assist may only warn the driver, or it may not operate.
 - Forward Collision-Avoidance Assist will operate under certain conditions by judging the risk level based on the condition of the oncoming vehicle, motorcyclist, driving direction, speed and surroundings.
 - Forward Collision-Avoidance Assist may be limited or disabled if the vehicle speed is too fast or the speed difference with the other vehicle, motorcyclist, or cyclist is large.
-



Information

- In a situation where collision is imminent, braking may be assisted by Forward Collision-Avoidance Assist when braking is insufficient by the driver.
 - The images and colors in the instrument cluster may differ depending on the cluster type or theme selected in the infotainment system.
-

Forward Collision-Avoidance Assist malfunction and limitations

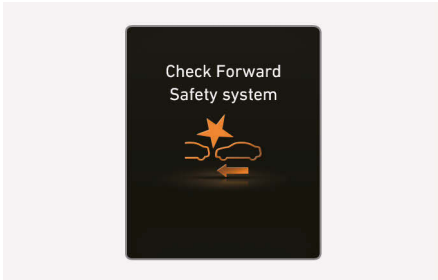
Forward Collision-Avoidance Assist malfunction



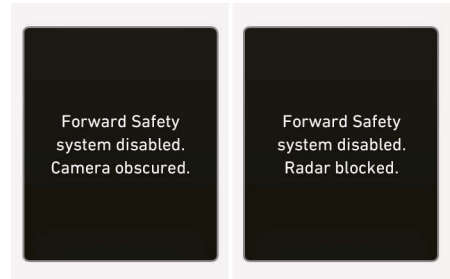

When Forward Collision-Avoidance Assist is not working properly, the "**Check Forward Safety system**" warning message will appear, and the ,  warning lights will illuminate on the instrument cluster. We recommend that your vehicle be inspected by an authorized HYUNDAI dealer.

Forward Collision-Avoidance Assist disabled



When the front windshield where the front view camera is located, front radar cover, bumper or sensor is covered with foreign material, such as snow or rain, it can reduce the detecting performance and temporarily limit or disable Forward Collision-Avoidance Assist.

If this occurs the "**Forward Safety system disabled. Camera obscured.**" or the "**Forward Safety system disabled. Radar blocked.**" warning message, and the , , or the  warning lights will illuminate on the instrument cluster.

Forward Collision-Avoidance Assist will operate properly when snow, rain or foreign material is removed.

If Forward Collision-Avoidance Assist does not operate properly after obstruction (snow, rain, or foreign material) is removed (including trailer, carrier, etc., from the rear bumper), we recommend that your vehicle be inspected by an authorized HYUNDAI dealer.



WARNING

- Even though the warning message or warning light does not appear on the cluster, Forward Collision-Avoidance Assist may not properly operate.
 - Forward Collision-Avoidance Assist may not properly operate in an area (for example, open terrain), where any objects are not detected after turning ON the vehicle.
 - If the vehicle is turned off and restarted while the camera is blocked or malfunctioned, the condition is maintained. Therefore, Forward Collision-Avoidance Assist is may not operate properly.
-

Limitations of Forward Collision-Avoidance Assist

Forward Collision-Avoidance Assist may not operate properly, or it may operate unexpectedly under the following circumstances:

- The detecting sensor or the surroundings are contaminated or damaged
- The temperature around the front view camera is high or low due to surrounding environment
- The camera lens is contaminated due to tinted, filmed or coated windshield, damaged glass, or sticky foreign material (sticker, bug, etc.) on the glass
- Moisture is not removed or frozen on the windshield
- Washer fluid is continuously sprayed, or the wiper is on
- Driving in heavy rain or snow, or thick fog
- The field of view of the front view camera is obstructed by sun glare
- Street light or light from an oncoming traffic is reflected on the wet road surface, such as a puddle on the road
- An object is placed on the dashboard
- Your vehicle is being towed
- The surrounding is very bright
- The surrounding is very dark, such as in a tunnel, etc.
- The brightness changes suddenly, for example when entering or exiting a tunnel
- The brightness outside is low, and the headlights are not on or are not bright

- Driving through steam, smoke or shadow
- Only part of the vehicle, motorcyclist, pedestrian or cyclist is detected
- The vehicle in front is a bus, heavy truck, truck with an unusually shaped cargo, trailer, etc.
- The vehicle or motorcycle in front has no tail lights, tail lights are located unusually, etc.
- The brightness outside is low, and the tail lights are not on or are not bright
- The rear of the front vehicle is small or the vehicle does not look normal, such as when the vehicle is tilted, overturned, or the side of the vehicle is visible, etc.
- The front vehicle's or motorcycle's ground clearance is low or high
- A vehicle, motorcyclist, pedestrian or cyclist suddenly cuts in front
- The bumper around the front radar is impacted, damaged or the front radar is out of position
- The temperature around the front radar is high or low
- Driving through a tunnel or iron bridge
- Driving in vast areas where there are few vehicles or structures (for example, desert, meadow, suburb, etc.)
- Driving near areas containing metal substances, such as a construction zone, railroad, etc.
- A material is near that reflects very well on the front radar, such as a guardrail, nearby vehicle, etc.
- The cyclist in front is on a bicycle made of material that does not reflect on the front radar
- The vehicle or motorcyclist in front is detected late
- The vehicle or motorcyclist in front is suddenly blocked by an obstacle
- The vehicle or motorcyclist in front suddenly changes lane or suddenly reduces speed
- The vehicle or motorcyclist in front is bent out of shape
- The front vehicle or motorcyclist speed is fast or slow
- The vehicle or motorcyclist in front steers in the opposite direction of your vehicle to avoid a collision
- With a vehicle or motorcyclist in front, your vehicle changes lane at low speed
- The vehicle or motorcyclist in front is covered with snow
- You are departing or returning to the lane
- Unstable driving
- You are on a roundabout and the vehicle in front is not detected
- You are continuously driving in a circle
- The vehicle or motorcyclist in front has an unusual shape
- The vehicle or motorcyclist in front is driving uphill or downhill
- The pedestrian or cyclist is not fully detected, for example, if the pedestrian is leaning over or is not fully walking upright

- The pedestrian or cyclist is wearing clothing or equipment that makes it difficult to detect

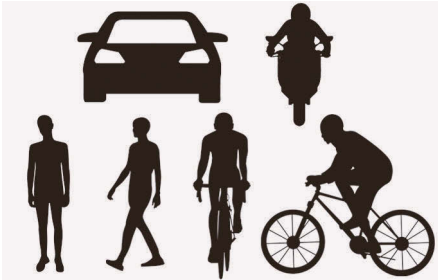

The illustration above shows the image the front view camera and front radar are capable of detecting as a vehicle, motorcyclist, pedestrian, and cyclist.

- The pedestrian or cyclist in front is moving very quickly
- The pedestrian or cyclist in front is short or is posing a low posture
- The pedestrian or cyclist in front has impaired mobility
- The pedestrian or cyclist in front is moving intersected with the driving direction
- There is a group of pedestrians, cyclists or a large crowd in front
- The pedestrian or cyclist is wearing clothing that easily blends into the background, making it difficult to detect
- The pedestrian or cyclist is difficult to distinguish from the similarly shaped structure in the surroundings
- You are driving by a pedestrian, cyclist, traffic signs, structures, etc., near the intersection
- You are driving through steam, smoke, or shadow.
- You are driving through a tunnel or an iron bridge.
- You are driving in large, open areas where there are few vehicles or structures (for example, desert, meadow, empty suburb).
- You are driving through roads with railroad tracks or other embedded metal objects.
- Driving in a parking lot
- Driving through a tollgate, construction area, unpaved road, partial paved road, uneven road, speed bumps, etc.
- Driving on an incline road, curved road, etc.
- Driving through a roadside with trees or streetlights
- The adverse road conditions cause excessive vehicle vibrations while driving
- Your vehicle height is low or high due to heavy loads, abnormal tire pressure, etc.
- Driving through a narrow road where trees or grass are overgrown
- There is interference by electromagnetic waves, such as driving in an area with strong radio waves or electrical noise
- The vehicle is installed with a snow chain, spare tire or different size wheel.

⚠ WARNING

• Driving on a curved road

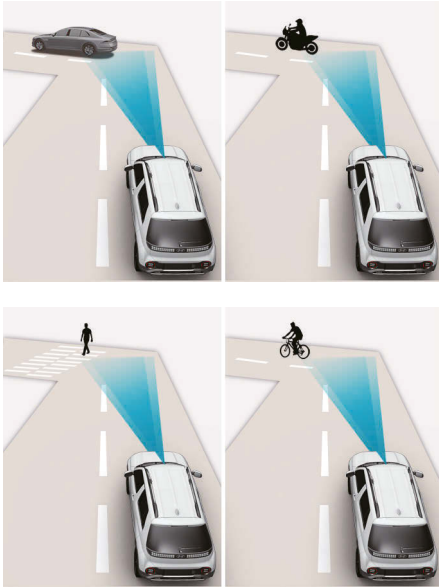

Forward Collision-Avoidance Assist may not detect other a vehicle, a motorcyclist, a pedestrian or a cyclist in front of you when driving on curved roads adversely affecting the performance of the sensors. This may result in no warning, braking assist when necessary.

When driving on a curve, you must maintain a safe braking distance, and if necessary, depress the brake pedal to reduce your driving speed in order to maintain a safe distance.

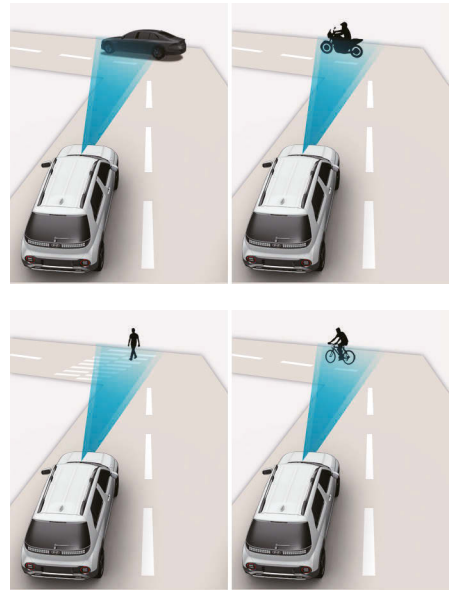

Forward Collision-Avoidance Assist may detect a vehicle, a motorcyclist, a pedestrian or a cyclist in the next lane or outside the lane when driving on a curved road.

If this occurs, Forward Collision-Avoidance Assist may unnecessarily warn the driver and control the brake. Always check the traffic conditions around the vehicle.

• **Driving on an inclined road**

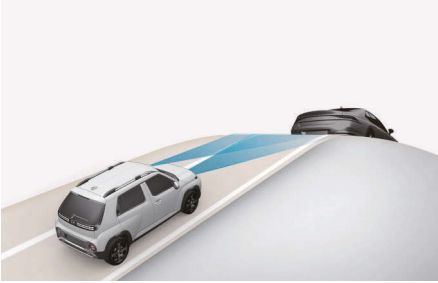

Forward Collision-Avoidance Assist may not detect other a vehicle, a motorcyclist, a pedestrian or a cyclist in front of you while driving uphill or downhill, adversely affecting the performance of the sensors.

This may result in unnecessary warning, braking assist no warning, braking assist when necessary.

Also, vehicle speed may rapidly decrease when a vehicle, motorcycle, pedestrian or cyclist ahead is suddenly detected.

Always have your eyes on the road while driving uphill or downhill and if necessary, steer your vehicle and depress the brake pedal to reduce your driving speed in order to maintain a safe distance.

• Changing lanes

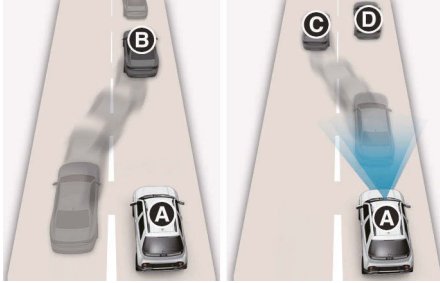

- [A] Your vehicle
- [B] Lane changing vehicle
- [C] Lane changing vehicle
- [D] Same lane vehicle or motorcyclist

When a vehicle or motorcycle moves into your lane from an adjacent lane, it cannot be detected by the sensor until it is in the sensor's detection range. Forward Collision-Avoidance Assist may not immediately detect the vehicle or motorcyclist when the vehicle or motorcyclist changes lanes abruptly. In this case, you must maintain a safe braking distance, and if necessary, steer your vehicle and depress the brake pedal to reduce your driving speed in order to maintain a safe distance.

When a vehicle in front of you lane change to the next lane, Forward Collision-Avoidance Assist may not immediately detect the vehicle or motorcyclist that is now in front of you. In this case, you must maintain a safe braking distance, and if necessary, steer your vehicle and depress the brake pedal to reduce your driving speed in order to maintain a safe distance.

• Detecting vehicle

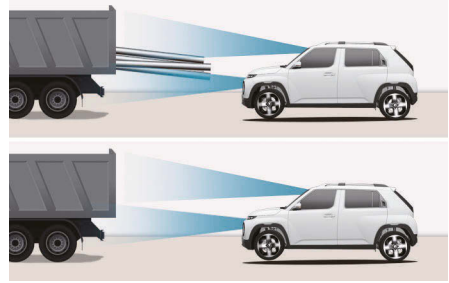

If the vehicle in front of you has cargo that extends rearward from the cab, or when the vehicle in front of you has higher ground clearance, additional special attention is required. Forward Collision-Avoidance Assist may not be able to detect the cargo extending from the vehicle. In these instances, you must maintain a safe braking distance from the rearmost object, and if necessary, steer your vehicle and depress the brake pedal to reduce your driving speed in order to maintain distance.

WARNING

- When you are towing a trailer or another vehicle, turn off Forward Collision-Avoidance Assist for safety reasons.
- Forward Collision-Avoidance Assist may operate if objects that are similar in shape or characteristics to a vehicle, a motorcyclist, a pedestrian or a cyclist is detected.
- Forward Collision-Avoidance Assist does not recognize carts, bicycles, suitcases, strollers, etc. pulled or pushed by a pedestrian or a cyclist.
- Forward Collision-Avoidance Assist may not operate properly if interfered by strong electromagnetic waves.
- Forward Collision-Avoidance Assist may not operate for 15 seconds after the vehicle is started, or the front view camera is initialized.

Lane Keeping Assist (LKA)

While driving over a certain speed, Lane Keeping Assist detects lane markings (or road edges) and may warn you if your vehicle leaves the lane without using the turn signal and may assist with steering to prevent your vehicle departing from its travel lane.

Detecting sensor



(1) Front view camera

The front view camera is used as a detecting sensor to detect lane markings (or road edges).

See the illustration above for the detailed location of the detecting sensor.

CAUTION

For more information on the precautions of the front view camera, refer to the "Forward Collision-Avoidance Assist (FCA) (Front view camera only)" section in this chapter.

Lane Keeping Assist settings

Lane safety

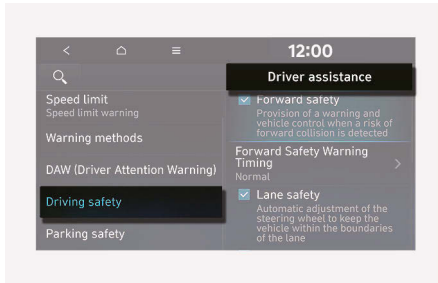

With the vehicle on, select **User Settings > Driver Assistance > Driving Safety > Lane Safety** in the instrument cluster or **Settings > Vehicle > Driver assistance > Driving safety > Lane safety** in the infotainment system to set whether to use each function.

If **Lane safety** is selected, Lane Keeping Assist automatically assists the driver's steering when lane departure is detected to help prevent the vehicle from moving out of its lane. If **Lane safety** is deselected, Lane Keeping Assist turns off and the yellow  indicator light appears on the cluster.

WARNING

- If the vehicle is restarted, Lane Keeping Assist turns on and **Lane safety** is selected.
- Lane Keeping Assist does not control the steering wheel when the vehicle is driven in the middle of the lane.
- The driver should always be aware of the surroundings. If **Lane safety** is deselected, Lane Keeping Assist cannot assist you.
- When the vehicle and the trailer is connected electrically, a warning message appears on the cluster, and Lane Keeping Assist is deactivated. The function resumes after the trailer connector is disconnected. (if Hyundai genuine part equipped)

Warning methods

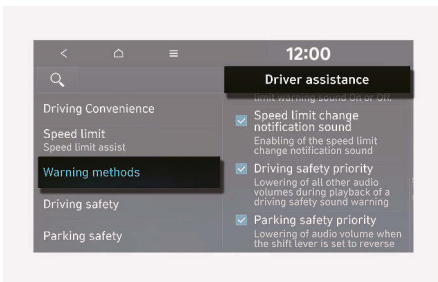
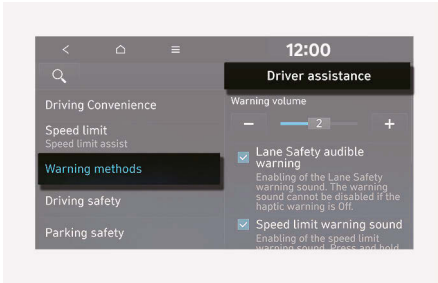

With the vehicle on, select **User Settings > Driver Assistance > Warning Methods > Warning Volume** on the instrument cluster or **Settings > Vehicle > Driver assistance > Warning methods** in the infotainment system to select following:

- **Warning volume:** The warning volume can be adjusted.
- **Driving safety priority:** Your vehicle lowers all other audio volumes when the Driver Assistance system warning sounds.



i Information

- If you change the Warning methods, the Warning methods of other Driver Assistance systems may change.
- Warning methods will maintain its last setting even if the vehicle is restarted.
- The setting menu may not be available for your vehicle depending on the vehicle features and specifications.



Lane Keeping Assist operation

Turning Lane Keeping Assist On/Off



- For Europe, Russia
Whenever the vehicle is turned on, Lane Keeping Assist always turn on. The grey  indicator light illuminates on the cluster. When Lane Keeping Assist is on, press and hold the Lane Driving Assist (/⊕\) button to turn off the function.
- Except Europe, Russia
With the vehicle ON, press and hold the Lane Driving Assist (/⊕\) button located on the steering wheel to turn on and off. When Lane Keeping Assist is on, the grey or green  indicator is on.
- When Lane Keeping Assist turns off, the  indicator turns yellow.

i Information

- When Lane Keeping Assist is ready to operate, the  indicator turns gray on the cluster.
- When Lane Keeping Assist is operating, the  indicator turns green on the cluster.

Warning and control

Lane Keeping Assist will warn and control the vehicle with Lane Departure Warning and Lane Keeping Assist.

Left/Right

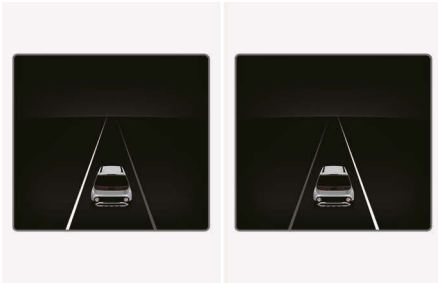

Lane Departure Warning

- To warn the driver that the vehicle is departing from the projected lane in front, the green  indicator light blinks on the cluster, the lane line blinks on the cluster depending on which direction the vehicle is veering, and an audible warning sounds.
- Lane Departure Warning will operate when your vehicle speed is between about 60-200 km/h (40-120 mph).

Lane Keeping Assist

- To warn the driver that the vehicle is departing from the projected lane in front, the green  indicator light blinks on the cluster, and the steering wheel makes adjustments to keep vehicle inside the lane.
- Lane Keeping Assist will operate when your vehicle speed is between about 60-200 km/h (40-120 mph)

Hands-off warning

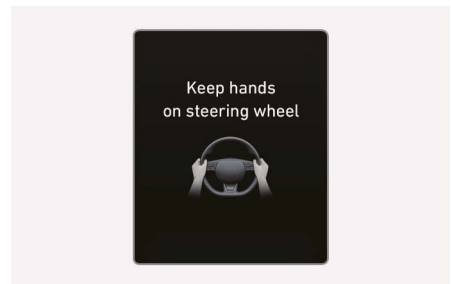

If the driver takes their hands off the steering wheel for several seconds, the "**Keep hands on steering wheel**" warning message appears on the cluster, and an audible warning sounds in stages.

! WARNING

- The steering wheel may not be assisted if the steering wheel is held very tight or the steering wheel is steered over a certain degree.
- Lane Keeping Assist does not operate at all times. It is the responsibility of the driver to safely steer the vehicle and to maintain the vehicle in its lane.
- The hands-off warning message may appear late depending on road conditions. Always have your hands on the steering wheel while driving.
- If the steering wheel is held very lightly, the hands-off warning message may appear because Lane Keeping Assist may not recognize that the driver has their hands on the steering wheel.
- If you attach objects to the steering wheel, the hands-off warning may not work properly.

i Information

- For more information on instrument cluster settings, refer to the "Cluster display (Type B)" section in chapter 4.
- When lane markings (or road edges) are detected, the lane lines on the cluster changes from gray to white.

Lane undetected



Lane detected



- The images and colors in the instrument cluster may differ depending on the cluster type or theme selected in the infotainment system.
- Even though the steering is assisted by Lane Keeping Assist, the driver may control the steering wheel.
- The steering wheel may feel heavier or lighter when the steering wheel is assisted by Lane Keeping Assist than when it is not.

Lane Keeping Assist malfunction and limitations

Lane Keeping Assist malfunction



When Lane Keeping Assist is not working properly, the "**Check Lane Safety system**" warning message and yellow Lane Keeping Assist (LKA) warning light appears on the cluster. If this occurs, we recommend that your vehicle be inspected by an authorized HYUNDAI dealer.

Lane Keeping Assist disabled



When the front windshield where the front view camera is located, or sensor is covered with foreign material, such as snow or rain, it can reduce the detecting performance and temporarily limit or disable Lane Keeping Assist.

If this occurs, the "**Lane Safety system disabled. Camera obscured.**" warning message and the master (LKA) warning light or Lane Keeping Assist (LKA) warning light appears on the instrument cluster.

Lane Keeping Assist operates properly when snow, rain or foreign material is removed.

If Lane Keeping Assist does not operate properly after it is removed, we recommend that your vehicle be inspected by an authorized HYUNDAI dealer.

WARNING

- Even though the warning message does not appear on the instrument cluster, Lane Keeping Assist may not properly operate.
- If the vehicle is turned off and restarted while the camera is blocked or malfunctioned, the condition is maintained. Therefore, Lane Keeping Assist may not operate properly.

Limitations of Lane Keeping Assist

Lane Keeping Assist may not operate properly or may operate unexpectedly under the following circumstances:

- The lane is contaminated or difficult to detect because:
 - The lane markings (or road edge) are covered with rain, snow, dirt, oil, etc.
 - The color of the lane marking (or road edge) is not distinguishable from the road
 - There are markings (or road edges) on the road near the lane or the markings (or road edges) on the road look similar to the lane markings (or road edge)
 - The lane marking (or road edge) is indistinct or damaged
 - The shadow is on the lane marking (or road edge) by a median strip, trees, guardrail, noise barriers, etc.
- The lane number increases or decreases, or the lane markings (or road edges) are crossing
- There are more than two lane markings (or road edges) on the road
- The lane markings (or road edges) are complicated or a structure substitutes for the lines, such as a construction area
- There are road markings, such as zigzag lanes, crosswalk markings and road signs
- The lane suddenly disappears, such as at the intersection
- The lane (or road width) is very wide or narrow
- There is a road edge without a lane

- There is a boundary structure in the roadway, such as a tollgate, sidewalk, curb, etc.
- The distance to the front vehicle is extremely short or the vehicle in front is covering the lane marking (or road edge)
- Driving on the left or right side of the median bus lane or on the median bus lane

***i* Information**

For more information on the limitations of the front view camera, refer to the "Forward Collision-Avoidance Assist (FCA) (Front view camera only)" section in this chapter.

WARNING

Take the following precautions when using Lane Keeping Assist:

- The driver has the responsibility to safely drive and control the vehicle. Do not solely rely on Lane Keeping Assist and drive dangerously.
 - The operation of Lane Keeping Assist can be canceled or not work properly depending on road conditions and surroundings. Always be cautious while driving.
 - Refer to Limitations of Lane Keeping Assist if the lane is not detected properly.
 - When you are towing a trailer or another vehicle, turn off Lane Keeping Assist for safety reasons.
 - If the vehicle is driven at high speed, the steering wheel will not be controlled. The driver must always follow the speed limit when using Lane Keeping Assist.
 - If any other system's warning message appears or audible warning is generated, Lane Keeping Assist warning message may not be displayed and audible warning may not be generated.
 - You may not hear the warning sound of Lane Keeping Assist if the surrounding is noisy.
 - If you attach objects to the steering wheel, steering may not be assisted properly.
- Lane Keeping Assist may not operate for 15 seconds after the vehicle is started, or the front view camera is initialized.
 - Lane Keeping Assist will not operate when:
 - Within a certain period of time after turning on or off the turn signal or hazard warning flasher.
 - The vehicle is not driven in the center of the lane when Lane Keeping Assist is turned on or right after changing a lane.
 - ESC (Electronic Stability Control) or VSM (Vehicle Stability Management) is activated.
 - The vehicle is driven on a sharp curve.
 - Vehicle speed is below or above operating conditions.
 - The vehicle makes sudden lane changes.
 - The vehicle brakes suddenly.

WARNING

Loading in excess of the maximum load allowance or concentrated loading at one point in the cargo compartment can reduce the vehicle's driving stability, which can in turn reduce the effectiveness of Lane Keeping Assist.

Blind-Spot Collision-Avoidance Assist (BCA)

 If equipped

Blind-Spot Collision-Avoidance Assist detects approaching vehicles in the driver's blind spot areas and warn you of a possible collision with a warning light and a warning sound.

If there is a collision risk when exiting a parallel space, Blind-Spot Collision-Avoidance Assist may assist with braking your vehicle to help avoid a collision.

Blind-Spot Collision-Avoidance Assist helps detect and informs the driver that a vehicle is in the blind spot.

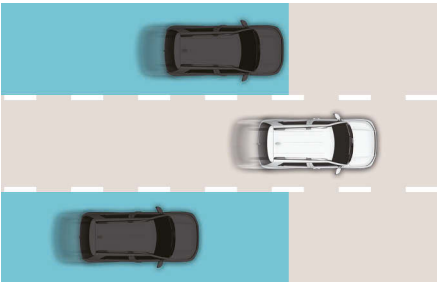

CAUTION

The detecting range may vary depending on the speed of your vehicle. Even if there is a vehicle in the blind spot area, Blind-Spot Collision-Avoidance Assist may not warn you when you pass by at high speeds.

Blind-Spot Collision-Avoidance Assist helps detect and informs the driver that a vehicle is approaching at high speed from the blind spot area.

CAUTION

Warning timing may vary depending on the speed of the vehicle approaching at high speed.

When you are driving forward out of a parking space, if Blind-Spot Collision-Avoidance Assist judges that there is a collision risk with an approaching vehicle in the blind spot, it can help avoid collision by applying the brake.

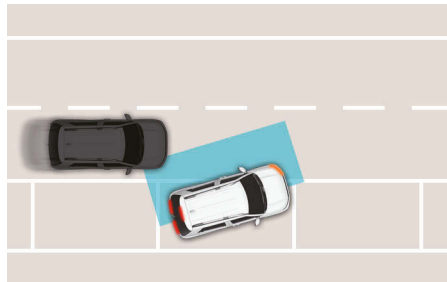

Detecting sensor

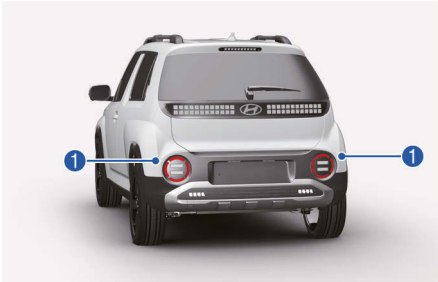

(1) Rear corner radar

Refer to the picture above for the detailed location of the detecting sensors.

CAUTION

Take the following precautions to maintain optimal performance of the detecting sensor:

- Never disassemble the detecting sensor assembly, or cause any damage to it.
 - If the rear corner radar or near the radar has been damaged or impacted in any way, even though the warning message does not appear on the cluster, Blind-Spot Collision-Avoidance Assist may not operate properly. We recommend that your vehicle be inspected by an authorized HYUNDAI dealer.
 - If the rear corner radars have been replaced or repaired, we recommend that your vehicle be inspected by an authorized HYUNDAI dealer.
 - Use only genuine parts to repair the rear bumper where the rear corner radar is located.
-
- Rear bumper genuine parts with rear corner radars have proven their performance. Replacing or painting the rear bumper may result in poor performance of Blind-Spot Collision-Avoidance Assist. When the parts need to be replaced or modified, make sure to use qualified products.
 - Do not apply license plate frame or objects, such as a bumper sticker, film or a bumper guard near the rear corner radar.
 - Blind-Spot Collision-Avoidance Assist may not work properly if the bumper has been replaced, or the surroundings of the rear corner radar have been damaged or paint has been applied.
 - If a trailer, carrier, etc., is installed, it may adversely affect the performance of the rear corner radar or Blind-Spot Collision-Avoidance Assist may not operate.

Blind-Spot Collision-Avoidance Assist settings

Blind-spot safety

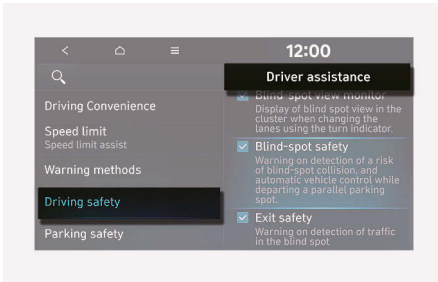

With the vehicle on, select **User Settings > Driver Assistance > Driving Safety > Blind-Spot Safety** in the instrument cluster or **Settings > Vehicle > Driver assistance > Driving safety > Blind-spot safety** in the infotainment system to set whether to use each function.

- If **Blind-spot safety** is selected, Blind-Spot Collision-Avoidance Assist warns the driver with a warning message, an audible warning depending on the collision risk levels. Braking assist is applied for parking exit depending on the collision risk levels.



When the vehicle is restarted with Blind-Spot Collision-Avoidance Assist off, the **"Blind-Spot Safety System is Off"** message will appear on the instrument cluster.

If you select **Blind-spot safety**, warning light on the outside rearview mirror will blink for three seconds. In addition, if the vehicle is turned on, when **"Blind-spot safety"** is selected, the warning light on the outside rearview mirror blinks for three seconds.

WARNING

- The driver should always be aware of the surroundings and drive safely. If **Blind-spot safety** is deselected, Blind-Spot Collision-Avoidance Assist cannot assist you.
- When the vehicle and the trailer is connected electrically, a warning message appears on the cluster, and Blind-Spot Collision-Avoidance Assist is deactivated. The function resumes after the trailer connector is disconnected. (if Hyundai genuine part equipped)

Information

If the vehicle is restarted, Blind-Spot Collision-Avoidance Assist maintains the last setting.

Warning methods

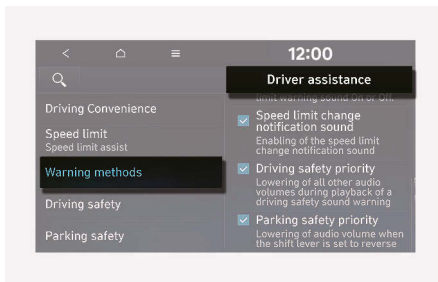
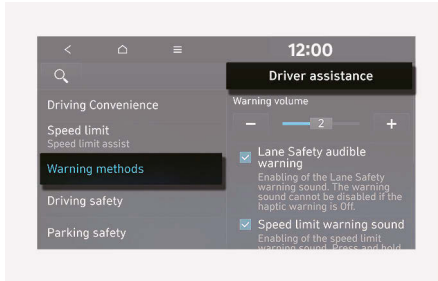

With the vehicle on, select **User Settings > Driver Assistance > Warning Methods > Warning Volume** on the instrument cluster or **Settings > Vehicle > Driver assistance > Warning methods** in the infotainment system to select following:

- **Warning volume:** The warning volume can be adjusted.
- **Driving safety priority:** Your vehicle lowers all other audio volumes when the Driver Assistance system warning sounds.

i Information

- If you change the Warning methods, the Warning methods of other Driver Assistance systems may change.
- Warning methods will maintain its last setting even if the vehicle is restarted.
- The setting menu may not be available for your vehicle depending on the vehicle features and specifications.

Blind-Spot Collision-Avoidance Assist operation

Driving-Warning



To warn the driver a vehicle is detected, the warning light on the outside rearview mirror illuminates. Vehicle detection operates under following conditions.

- Your vehicle speed: above 20-255 km/h (12-155 mph)
- Vehicle in the blind spot area: above 10 km/h (6 mph)

Collision warning operates when the turn signal is turned on in the direction of the detected vehicle.

- To warn the driver of a collision, the warning light on the outside rearview mirror blinks. At the same time, an audible warning sounds.
- When the turn signal is turned off, the collision warning is canceled and Blind-Spot Collision-Avoidance Assist returns to vehicle detection state.

Collision warning operates under following conditions.

- Your vehicle speed: above 40-255 km/h (25-155 mph)
- Vehicle in the blind spot area: above 10 km/h (6 mph)

WARNING

- The detecting range of the rear corner radar is determined by a standard road width, therefore, on a narrow road, Blind-Spot Collision-Avoidance Assist may detect other vehicles two lanes over and warn you. In contrast, on a wide road, Blind-Spot Collision-Avoidance Assist may not be able to detect a vehicle driving in the next lane and may not warn you.
- When the hazard warning flasher is on, the collision warning by the turn signal will not operate.

Information

If the driver's seat is on the left side, the collision warning may occur when you turn left. Maintain a proper distance with the vehicles in the left lane. If the driver's seat is on the right side, the collision warning may occur when you turn right. Maintain a proper distance with the vehicles in the right lane.

The images and colors in the instrument cluster may differ depending on the cluster type or theme selected in the infotainment system.

Collision-avoidance assist (while parallel parking exit)

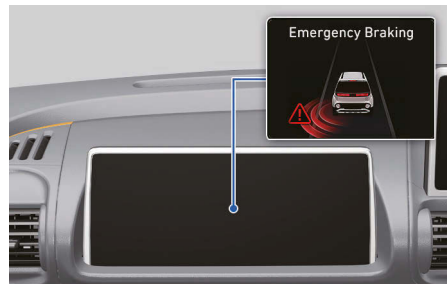

- To warn the driver of a collision, the warning light on the outside rearview mirror will blink and a warning message will appear on the instrument cluster. At the same time, an audible warning will sound.
- Emergency braking will be assisted to help prevent collision with the vehicle in the blind spot area.

- Blind-Spot Collision-Avoidance Assist will operate when your vehicle speed is below 3 km/h (2 mph) and the speed of the vehicle in the blind spot area is above 5 km/h (3 mph).
- When the vehicle is stopped due to emergency braking, the "**Drive carefully**" warning message will appear on the cluster.

For your safety, the driver should depress the brake pedal immediately and check the surroundings.



- Brake control will end after the vehicle is stopped by emergency braking for about 2 seconds.

WARNING

Take the following precautions when using Blind-Spot Collision-Avoidance Assist:

- For your safety, only change the Settings after parking the vehicle at a safe location.
- If any other system's warning message appears or audible warning is generated, Blind-Spot Collision-Avoidance Assist's warning message may not be displayed and audible warning may not be generated.
- You may not hear the warning sound of Blind-Spot Collision-Avoidance Assist if the surrounding is noisy.
- Blind-Spot Collision-Avoidance Assist may not operate if the driver applies the brake pedal to avoid a collision.
- When Blind-Spot Collision-Avoidance Assist is operating, braking control by the function will automatically cancel when the driver excessively depresses the accelerator pedal or sharply steers the vehicle.
- During Blind-Spot Collision-Avoidance Assist operation, the vehicle may stop suddenly injuring passengers and shifting loose objects. Always have the seat belt on and keep loose objects secured.
- Even if there is a problem with Blind-Spot Collision-Avoidance Assist, the vehicle's basic steering and braking performance will operate properly.
- Blind-Spot Collision-Avoidance Assist does not operate in all situations and cannot avoid all collisions.
- Blind-Spot Collision-Avoidance Assist may warn the driver late or may not warn the driver depending on the road and driving conditions.

- Driver should maintain control of the vehicle at all times. Do not depend on Blind-Spot Collision-Avoidance Assist. Maintain a safe braking distance, and if necessary, depress the brake pedal to reduce driving speed or to stop the vehicle.
 - Never operate Blind-Spot Collision-Avoidance Assist on people, animal, objects, etc. It may cause serious injury or death.
-

WARNING

The brake control may not operate properly depending on the status of ESC (Electronic Stability Control).

There will only be a warning when:

- The ESC (Electronic Stability Control) warning light is on
 - ESC (Electronic Stability Control) is engaged in a different function
-

Blind-Spot Collision-Avoidance Assist malfunction and limitations

Blind-Spot Collision-Avoidance Assist malfunction

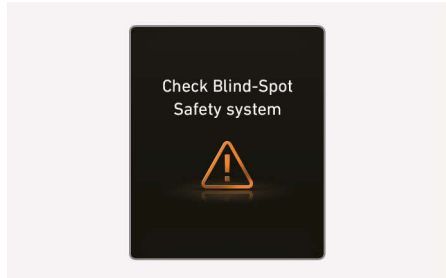

When Blind-Spot Collision-Avoidance Assist is not working properly, the "**Check Blind-Spot Safety system**" warning message will appear on the instrument cluster for several seconds, and the master () warning light will appear on the instrument cluster. If this occurs, we recommend that your vehicle be inspected by an authorized HYUNDAI dealer.

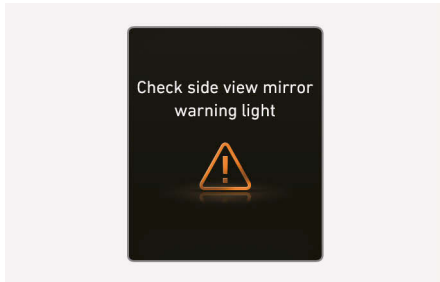

When the outside rearview mirror warning light is not working properly, the **"Check side view mirror warning light"** warning message will appear on the instrument cluster for several seconds, and the master (⚠) warning light will appear on the instrument cluster. If this occurs, we recommend that your vehicle be inspected by an authorized HYUNDAI dealer.

Blind-Spot Collision-Avoidance Assist disabled



When the rear bumper around the rear corner radar or sensor is covered with foreign material, such as snow or rain, or installing a trailer or carrier, it can reduce the detecting performance and temporarily limit or disable Blind-Spot Collision-Avoidance Assist.

If this occurs, the **"Blind-Spot Safety system disabled. Radar blocked."** warning message will appear on the cluster.

Blind-Spot Collision-Avoidance Assist will operate properly when such foreign material or trailer, etc., is removed, and then the vehicle is restarted.

If Blind-Spot Collision-Avoidance Assist does not operate properly after it is removed, we recommend that your vehicle be inspected by an authorized HYUNDAI dealer.

 **WARNING**

- Even though the warning message does not appear on the instrument cluster, Blind-Spot Collision-Avoidance Assist may not properly operate.
 - Blind-Spot Collision-Avoidance Assist may not properly operate in an area (for example, open terrain) where any objects are not detected right after the vehicle is turned on, or when the detecting sensor is blocked with foreign material right after the vehicle is turned on.
-

 **CAUTION**

Turn off Blind-Spot Collision-Avoidance Assist to install or remove a trailer, carrier, or another attachment. Turn on Blind-Spot Collision-Avoidance Assist when finished.

Limitations of Blind-Spot Collision-Avoidance Assist

Blind-Spot Collision-Avoidance Assist may not operate properly, or it may operate unexpectedly under the following circumstances:

- There is inclement weather, such as heavy snow, heavy rain, etc.
- The rear corner radar is covered with snow, rain, dirt, etc.
- The temperature around the rear corner radar is high or low
- Driving on a highway ramp
- The road pavement (or the peripheral ground) abnormally contains metallic components (for example, possibly due to subway construction)
- There is a fixed object near the vehicle, such as sound barriers, guardrails, central dividers, entry barriers, street lamps, signs, tunnels, walls, etc. (including double structures)
- Driving in vast areas where there are few vehicles or structures (for example, desert, meadow, suburb, etc.)
- Driving through a narrow road where trees or grass are overgrown
- Driving on a wet road surface, such as a puddle on the road
- The other vehicle drives very close behind your vehicle, or the other vehicle passes by your vehicle in close proximity
- The speed of the other vehicle is very fast that it passes by your vehicle in a short time
- Your vehicle passes by the other vehicle

- Your vehicle changes lane
- Your vehicle has started at the same time as the vehicle next to you and has accelerated
- The vehicle in the next lane moves two lanes away from you, or when the vehicle two lanes away moves to the next lane from you
- A trailer, carrier or other attachment is installed around the rear corner radar
- The bumper around the rear corner radar is covered with objects, such as a bumper sticker, bumper guard, bike rack, etc.
- The bumper around the rear corner radar is impacted, damaged or the radar is out of position
- Your vehicle height is low or high due to heavy loads, abnormal tire pressure, etc.

Blind-Spot Collision-Avoidance Assist may not operate properly, or it may operate unexpectedly when the following objects are detected:

- A motorcycle or bicycle is detected
- A vehicle such as a flat trailer is detected
- A big vehicle such as a bus or truck is detected
- A moving obstacle such as a pedestrian, animal, shopping cart or a baby stroller is detected
- A vehicle with low height such as a sports car is detected

Braking control may not work, driver's attention is required in the following circumstances:

- The vehicle severely vibrates while driving over a bumpy road, uneven road or concrete patch
- Driving on a slippery surface due to snow, water puddle, ice, etc.
- The tire pressure is low or a tire is damaged
- The braking system has been modified
- The vehicle makes abrupt lane changes

i Information

For more information on the limitations of the front view camera, refer to "Forward Collision-Avoidance Assist (FCA) (Front view camera only)" and "Lane Keeping Assist (LKA)" section in this chapter.

 **WARNING**

• **Driving on a curved road**

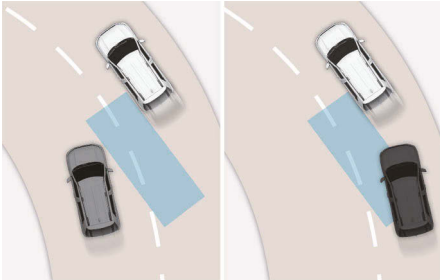

Blind-Spot Collision-Avoidance Assist may not operate properly when driving on a curved road. The function may not detect the vehicle in the next lane.

Always pay attention to road and driving conditions while driving.

Blind-Spot Collision-Avoidance Assist may not operate properly when driving on a curved road. The function may recognize a vehicle in the same lane.

Always pay attention to road and driving conditions while driving.

• **Driving on an inclined road**

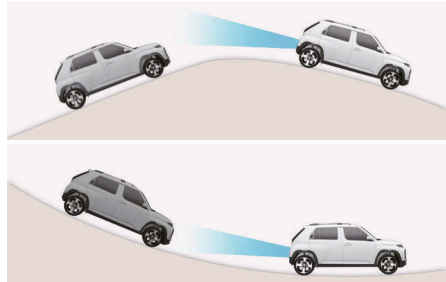

Blind-Spot Collision-Avoidance Assist may not operate properly when driving on a slope. The function may not detect the vehicle in the next lane or may incorrectly detect the ground or structure. Always pay attention to road and driving conditions while driving.

- **Driving where the road is merging/dividing**

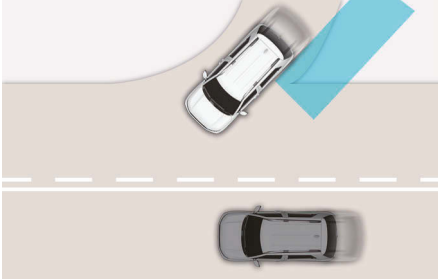

Blind-Spot Collision-Avoidance Assist may not operate properly when driving where the road merges or divides. The function may not detect the vehicle in the next lane.

Always pay attention to road and driving conditions while driving.

- **Driving where the heights of the lanes are different**



Blind-Spot Collision-Avoidance Assist may not operate properly when driving where the heights of the lanes are different. The function may not detect the vehicle on a road with different lane heights (underpass joining section, grade separated intersections, etc.).

Always pay attention to road and driving conditions while driving.

WARNING

- When you are towing a trailer or another vehicle, make sure that you turn off Blind-Spot Collision-Avoidance Assist.
- Blind-Spot Collision-Avoidance Assist may not operate properly if interfered by strong electromagnetic waves.
- Blind-Spot Collision-Avoidance Assist may not operate for about 3 seconds after the vehicle is started, or the front view camera or rear corner radars are initialized.

Safe Exit Warning (SEW)

 if equipped

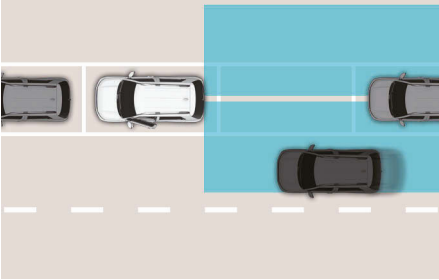

While your vehicle is stopped, and if Safe Exit Warning detects a vehicle approaching the rear corner of your vehicle and a passenger opens a door, Safe Exit Warning may warn you with a warning message and a warning sound to help avoid a collision.

CAUTION

Warning timing may vary depending on the speed of the approaching vehicle.

Detecting sensor



(1) Rear corner radar

Refer to the illustration above for the detailed location of the detecting sensors.

CAUTION

For more information on the precautions of the rear corner radars, refer to the "Blind-Spot Collision-Avoidance Assist (BCA)" section in this chapter.

Safe Exit Warning settings

Exit safety

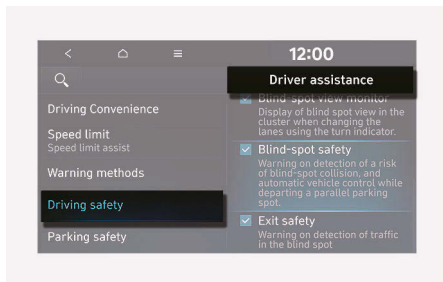

With the vehicle on, select **User Settings** > **Driver Assistance** > **Driving Safety** > **Exit Safety** in the instrument cluster or **Settings** > **Driver assistance** > **Driving safety** > **Exit safety** in the infotainment system to turn on Safe Exit Warning and deselect to turn off the function.

WARNING

- The driver should always be aware of his or her surroundings. If **Exit safety** is deselected, Safe Exit Warning cannot assist you.
- When the vehicle and the trailer is connected electrically, a warning message appears on the cluster, and Safe Exit Warning is deactivated. The function resumes after the trailer connector is disconnected. (if Hyundai genuine part equipped)

Information

If the vehicle is restarted, Safe Exit Warning will maintain the last setting.

Warning methods

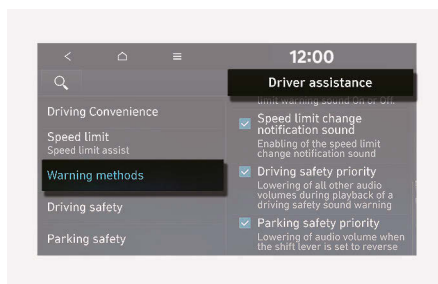
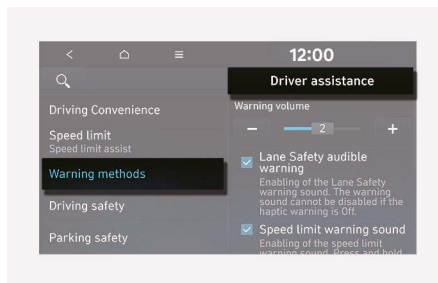

With the vehicle on, select **User Settings** > **Driver Assistance** > **Warning Methods** > **Warning Volume** on the instrument cluster or **Settings** > **Vehicle** > **Driver assistance** > **Warning methods** in the infotainment system to select following:

- **Warning volume:** The warning volume can be adjusted.
- **Driving safety priority:** Your vehicle lowers all other audio volumes when the Driver Assistance system warning sounds.

i Information

- If you change the Warning methods, the Warning Methods of other Driver Assistance systems may change.
- Warning methods will maintain its last setting even if the vehicle is restarted.
- The setting menu may not be available for your vehicle depending on the vehicle features and specifications.

Safe Exit Warning operation

Safe Exit Warning

Collision warning when exiting vehicle



- When an approaching vehicle from the rear is detected at the moment a door is opened, the "**Collision Warning**" warning message will appear on the cluster, and an audible warning will sound.
- Safe Exit Warning will warn the driver when your vehicle speed is below 3 km/h (2 mph), and the speed of the approaching vehicle from the rear is above 6 km/h (4 mph).

WARNING

Take the following precautions when using Safe Exit Warning:

- For your safety, change the Settings after parking the vehicle at a safe location.
- If any other system's warning message appears or audible warning is generated, Safe Exit Warning's warning message may not be displayed and audible warning may not be generated.
- You may not hear the warning sound of Safe Exit Warning if the surrounding is noisy.
- Safe Exit Warning does not operate in all situations or cannot prevent all collisions.
- Safe Exit Warning may warn the driver late or may not warn the driver depending on the road and driving conditions. Always check vehicle surroundings.
- The driver and passengers are responsible for accidents that occurs while exiting the vehicle. Always check the surroundings before you exit the vehicle.

Information

- After the vehicle is turned off, Safe Exit Warning operates for about 3 minutes, but turns off immediately if the doors are locked.
- The images and colors in the instrument cluster may differ depending on the cluster type or theme selected in the infotainment system.

Safe Exit Warning malfunction and limitations

Safe Exit Warning malfunction

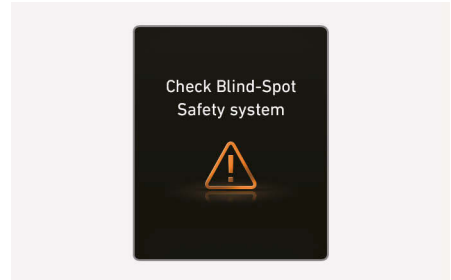

When Safe Exit Warning is not working properly, the "**Check Blind-Spot Safety system**" warning message will appear on the cluster for several seconds, and the master warning light () will appear on the cluster. If this occurs, we recommend that your vehicle be inspected by an authorized HYUNDAI dealer.

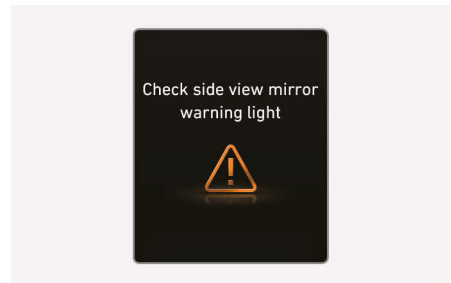

When the outside rearview mirror warning light is not working properly, the "**Check side view mirror warning light**" warning message will appear on the cluster for several seconds, and the master warning light () will appear on the cluster. If this occurs, we recommend that your vehicle be inspected by an authorized HYUNDAI dealer.

Safe Exit Warning disabled



When the rear bumper around the rear corner radar or sensor is covered with foreign material, such as snow or rain, or installing a trailer or carrier, it can reduce the detecting performance and temporarily limit or disable Safe Exit Warning.

If this occurs, the "**Blind-Spot Safety system disabled. Radar blocked.**" warning message will appear on the cluster.

Safe Exit Warning will operate properly when such foreign material or trailer, etc., is removed, and then the vehicle is restarted.

If Safe Exit Warning does not operate properly after it is removed, we recommend that your vehicle be inspected by an authorized HYUNDAI dealer.

WARNING

- Even though the warning message does not appear on the cluster, Safe Exit Warning may not properly operate.
- Safe Exit Warning may not properly operate in an area (for example, open terrain) where any objects are not detected right after the vehicle is turned on, or when the detecting sensor is blocked with foreign material right after the vehicle is turned on.

CAUTION

Turn off Safe Exit Warning to install or remove a trailer, carrier, or another attachment. Turn on Safe Exit Warning when finished.

Limitations of Safe Exit Warning

Safe Exit Warning may not operate properly, or it may operate unexpectedly under the following circumstances:

- Getting out of the vehicle where trees or grass are overgrown
- Getting out of the vehicle where the road is wet
- The approaching vehicle is very fast or very slow

i Information

For more information on the limitations of the rear corner radar, refer to the "Blind-Spot Collision-Avoidance Assist (BCA)" section in this chapter.

! WARNING

- Safe Exit Warning may not operate properly if interfered by strong electromagnetic waves.
- Safe Exit Warning may not operate for about 3 seconds after the vehicle is started, or the rear corner radars are initialized.
- If the vehicle is turned off and restarted while the radar is blocked or malfunctioned, the condition is maintained. Therefore, Safe Exit Warning may not operate properly.

Manual Speed Limit Assist (MSLA)

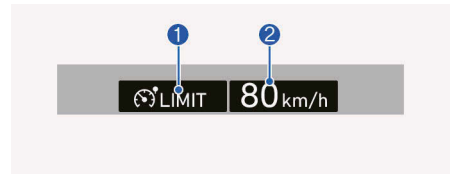



- (1) Speed Limit indicator
- (2) Set speed

You can set the speed limit when you do not want to drive over a specific speed.

If you drive over the preset speed limit, Manual Speed Limit Assist will operate (set speed limit will blink and chime will sound) until the vehicle speed returns within the speed limit.

Manual Speed Limit Assist operation

Setting speed limit

1. Press and hold the Driving Assist () button at the desired speed. The Speed Limit (LIMIT) indicator will appear on the cluster.



2. Push the **+** switch up or **-** switch down, and release it at the desired speed.
 - A short push of the switch upward or downward will increase or decrease the set speed by 1 km/h (1 mph).
 - A long push of the switch upward or downward will increase or decrease the set speed by 10 km/h (5 mph).



3. The set speed limit will be displayed on the cluster.

If you would like to drive over the preset speed limit, depress the accelerator pedal beyond the pressure point to activate the kickdown function.

The set speed limit will blink and chime will sound until you return the vehicle speed within the speed limit.

i Information

When the accelerator pedal is not depressed beyond the pressure point, vehicle speed will maintain within the speed limit.

Temporarily pausing Manual Speed Limit Assist



Press the **II** switch to temporarily pause the set speed limit. The set speed limit will turn off but the Speed Limit (**LIMIT**) indicator will stay on.

Resuming Manual Speed Limit Assist

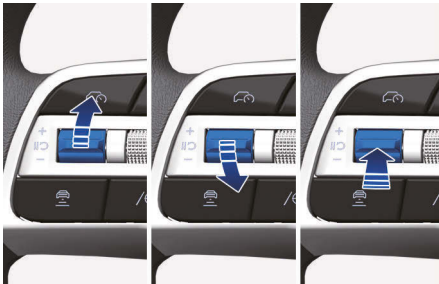

To resume Manual Speed Limit Assist after the function was paused, operate the **+**, **-**, **II** switch.

If you push the **+** switch up or **-** switch down, vehicle speed will be set to the current speed on the cluster.

If you press the **II** switch, vehicle speed will resume to the preset speed.

Turning off Manual Speed Limit Assist



Press the Driving Assist (**DA**) button to turn Manual Speed Limit Assist off. The Speed Limit (**LIMIT**) indicator will go off. Always press the Driving Assist (**DA**) button to turn Manual Speed Limit Assist off when not in use.

! WARNING

Take the following precautions when using Manual Speed Limit Assist:

- Always set the vehicle speed to the speed limit in your country.
- Keep Manual Speed Limit Assist off when the function is not in use, to avoid inadvertently setting a speed. Check that the Speed Limit (**LIMIT**) indicator is off.
- Manual Speed Limit Assist does not substitute for proper and safe driving. It is the responsibility of the driver to always drive safely and be aware of unexpected and sudden situations. Pay attention to the road conditions at all times.

Intelligent Speed Limit Assist (ISLA)

 If equipped

Intelligent Speed Limit Assist uses information from the detected road signs and uses the navigation system data to inform you of the speed limit and to help maintain within the speed limit on the road.

CAUTION

- Intelligent Speed Limit Assist may not operate properly if the function is used in other countries.
- If your vehicle is equipped with a navigation system, the navigation software needs to be regularly updated for Intelligent Speed Limit Assist to operate properly.
- The infotainment system may change after software updates. For more information, refer to the user's manual provided in the infotainment system and the quick reference guide.

Detecting sensor



(1) Front view camera

Refer to the illustration above for the detailed location of the detecting sensor.

CAUTION

For more information on the precautions of the front view camera, refer to the "Forward Collision-Avoidance Assist (FCA) (Front view camera only)" section in this chapter.

Intelligent Speed Limit Assist Settings

Speed limit

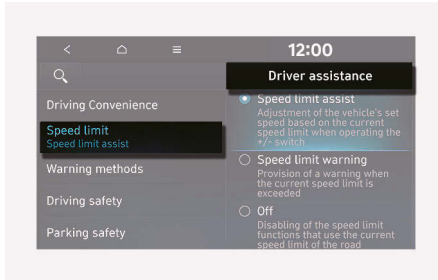

With the vehicle on, select or deselect **User Settings > Driver Assistance > Speed Limit** from the settings menu in the instrument cluster or **Settings > Vehicle > Driver assistance > Speed limit** from the infotainment system to set whether to use each function.

- **Country Selection**(if navigation is not equipped): When the navigation system is not available, you can manually select the country to set the speed limit.
- **Speed limit assist:** Intelligent Speed Limit Assist will inform the driver of speed limit and additional road signs, and warn the driver if the vehicle speed is faster than the speed limit. In addition, Intelligent Speed Limit Assist will inform the driver to change set speed of Manual Speed Limit Assist and/or Smart Cruise Control to help the driver stay within the speed limit.

- **Speed limit warning:** Intelligent Speed Limit Assist will inform the driver of speed limit. In addition, Intelligent Speed Limit Assist will warn the driver when the vehicle is driven faster than the speed limit.
- **Off:** Intelligent Speed Limit Assist will turn off. The  warning light is displayed.

WARNING

- When the vehicle is restarted, Intelligent Speed Limit Assist will always turn on. However, if **Off** and the vehicle is restarted, **Speed limit warning** is selected.
- For your safety, only change the Settings after parking the vehicle at a safe location.
- Intelligent Speed Limit Assist does not substitute for proper and safe driving. It is the responsibility of the driver to always drive safely and be aware of unexpected and sudden situations. Pay attention to the road conditions at all times.

Warning methods

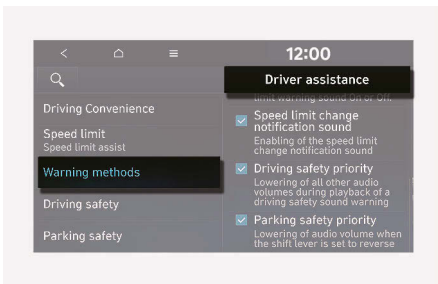
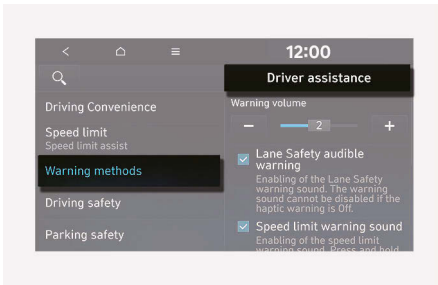

With the vehicle on, select **User Settings > Driver Assistance > Warning Methods > Warning Volume** on the instrument cluster or **Settings > Vehicle > Driver assistance > Warning methods** from the infotainment system to select following:

- **Warning volume:** The warning volume can be adjusted.
- **Speed limit warning sound:** The Speed limit warning sound can be turned on or off.
- **Speed limit change notification sound:** The Speed limit change notification sound can be turned on or off.

i Information

- If you change the Warning methods, the Warning methods of other Driver Assistance systems may change.
- Warning methods will maintain its last setting even if the vehicle is restarted.
- The setting menu may not be available for your vehicle depending on the vehicle features and specifications.
- Press and hold the  button on the steering wheel to turn on or off the Speed Limit warning sound.

! WARNING

When the vehicle is restarted, Speed Limit Warning Sound will always turn on.

Intelligent Speed Limit Assist Operation

Warning and control

Intelligent Speed Limit Assist will warn and control the vehicle speed by Displaying speed limit, Warning overspeed and Changing set speed.

Displaying speed limit



Speed limit information is displayed on the instrument cluster.

i Information

- If speed limit information of the road cannot be recognized, '---' sign will be displayed. Please refer to Limitations of Intelligent Speed Limit Assist section, if the road signs are difficult to recognize.
- Intelligent Speed Limit Assist provides additional road sign information in addition to speed limit. The additional road sign information provided may vary according to your country.
- Supplementary sign displayed under the speed limit or overtaking restriction sign means the conditions under which the signs must be followed. If the supplementary sign is not recognized, it will be displayed as blank.
- The images and colors in the instrument cluster may differ depending on the cluster type or theme selected from the instrument cluster.

Warning overspeed



When driving at a speed higher than the displayed speed limit, the red speed limit indicator will blink and warning sounds.

Changing set speed



If the speed limit of the road changes during the operation of Manual Speed Limit Assist or Smart Cruise Control, an arrow in the direction of up or down is displayed to inform the driver that the set speed needs to be changed. At this time, the driver can change the set speed according to the speed limit by using the \uparrow or \downarrow switch on the steering wheel.

Set Speed Auto Change (if equipped with navigation)

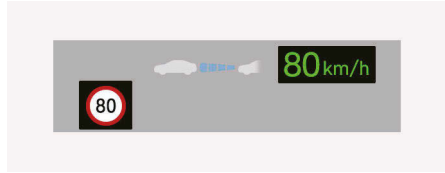

Manual Speed Limit Assist or Smart Cruise Control assists the vehicle to adjust its speed according to the speed limit. When the cruising speed is set as same as the speed limit, the vehicle automatically adjusts its speed if the speed limit changes. The function operates on the road which has a speed limit of 70 km/h (45 mph) or higher. When the function is active, the cruising speed on the instrument cluster appears in green.

WARNING

- Even after changing the set speed according to the speed limit of the road, the vehicle can still be driven over the speed limit. If necessary, depress the brake pedal to reduce your driving speed.
- If the speed limit of the road is under 30 km/h (20 mph), the set speed change function will not work.
- Intelligent Speed Limit Assist operates using the speed units in the instrument cluster set by the driver. If the speed unit is not set to the speed unit used in your state, Intelligent Speed Limit Assist may not operate properly.

i Information

- For more information on Manual Speed Limit Assist operation, refer to the "Manual Speed Limit Assist (MSLA)" section in this chapter.
- For more information on Smart Cruise Control operation, refer to the "Smart Cruise Control (SCC)" section in this chapter.

Intelligent Speed Limit Assist Malfunction and Limitations

Intelligent Speed Limit Assist malfunction

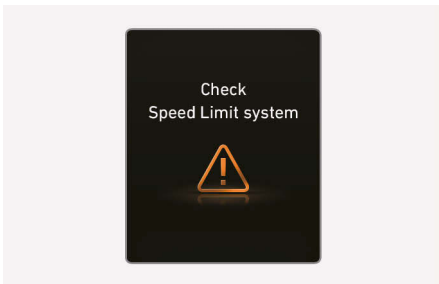

When Intelligent Speed Limit Assist is not working properly, the "**Check Speed Limit system**" warning message will appear on the instrument cluster for several seconds, and the master (\triangle) warning light and speed limit (\ominus) warning light will appear on the instrument cluster. If this occurs, we recommend that your vehicle be inspected by an authorized HYUNDAI dealer.

Intelligent Speed Limit Assist disabled



When the front windshield where the front view camera is located is covered with foreign material, such as snow or rain, it can reduce the detecting performance and temporarily limit or disable Intelligent Speed Limit Assist. If this occurs, the "**Speed Limit system disabled. Camera obscured.**" warning message and the speed limit (\ominus) warning light will appear on the instrument cluster.

Intelligent Speed Limit Assist will operate properly when snow, rain or foreign material is removed.

If Intelligent Speed Limit Assist does not operate properly after it is removed, we recommend that your vehicle be inspected by an authorized HYUNDAI dealer.



WARNING

- Even though the warning message or warning light does not appear on the instrument cluster, Intelligent Speed Limit Assist may not properly operate.
 - If the vehicle is turned off and restarted while the camera is blocked or malfunctioned, the condition is maintained. Therefore, Intelligent Speed Limit Assist may not operate properly.
-

Limitations of Intelligent Speed Limit Assist

Intelligent Speed Limit Assist may not operate properly, or it may operate unexpectedly under the following circumstances:

- The road sign is contaminated or indistinguishable
- The road sign is difficult to see due to bad weather, such as rain, snow, fog, etc.
- The road sign is not clear or damaged
- The road sign is partially obscured by surrounding objects or shadow
- The road signs do not conform to the standard
- The text or illustration on the road sign is different from the standard
- The road sign is installed between the main line and the exit road or between diverging roads
- There is no conditional road signs on the road sign located on the exit road
- A sign is attached to another vehicle
- The distance between the vehicle and the road signs is too far
- The vehicle encounters illuminant road signs
- Intelligent Speed Limit Assist incorrectly recognizes numbers or illustrations in the street signs or other signs as the speed limit
- A road sign near the road you are driving is detected
- The other traffic sign or signboards are alongside the road sign

- Multiple signs are installed close together
- The minimum speed limit sign is misrecognized
- The minimum speed limit sign is on the road
- The brightness changes suddenly, for example when entering or exiting a tunnel or passing under a bridge
- Headlights are not used or the brightness of the headlights are weak at night or in the tunnel
- Road signs are difficult to recognize due to the reflection of sunlight, street lights, or oncoming vehicles
- The navigation information or GPS information contain errors.
- The driver does not follow the guide of the navigation.
- The driver is driving on a new road that is not in the navigation system yet.
- The field of view of the front view camera is obstructed by sun glare
- Driving on a road that is sharply curved or continuously curved
- Driving through speed bumps, or driving up and down or left to right on steep inclines
- The vehicle is shaking heavily
- Driving on a newly opened road
- Driving through a construction area
- The navigation software is being updated while driving
- The navigation is restarted while driving

WARNING

- Intelligent Speed Limit Assist is a supplemental function that helps the driver to comply with the speed limit on the road, and may not display the correct speed limit or control the driving speed properly.
 - Always set the vehicle speed to the speed limit in your area.
 - Intelligent Speed Limit Assist may not operate for 15 seconds after the vehicle is started, or the front camera is initialized.
-

i Information

For more information on the limitations of the front view camera, refer to the "Forward Collision-Avoidance Assist (FCA) (Front view camera only)" section in this chapter.

Driver Attention Warning (DAW)

Driver Attention Warning

Driver Attention Warning monitors your driving pattern while driving. When the driver's attention level is below a certain level, Driver Attention Warning recommends a break to help with safe driving.

Leading vehicle departure alert function

Leading Vehicle Departure Alert function will inform the driver when a detected vehicle in front departs.

Detecting sensor



(1) Front view camera

The front view camera is used as a detecting sensor to help detect driving patterns and front vehicle departure while vehicle is being driven.

See the illustration above for the detailed location of the detecting sensor.

⚠ CAUTION

- Always keep the front view camera in good condition to maintain optimal performance of Driver Attention Warning.
 - For more information on the precautions of the front view camera, refer to the "Forward Collision-Avoidance Assist (FCA) (Front view camera only)" section in this chapter.
-

Driver Attention Warning settings

Driver Attention Warning

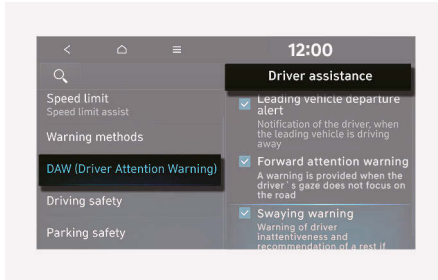

With the vehicle on, select or deselect **Settings > Vehicle > Driver assistance > DAW (Driver Attention Warning)** and then enable **Leading vehicle departure alert** in the infotainment system to set whether to use each function.

- If **Leading vehicle departure alert** is selected, the function will inform the driver when a detected vehicle in front departs from a stop.
- If **Swaying warning** is selected, Driver Attention Warning will inform the driver the driver's attention level and will recommend taking a break when the level falls below a certain level.

i Information

Swaying warning menu will not be displayed in a region where the Driver Attention Warning function operates always.

Driver Attention Warning operation

Inattentive Driving Warning

The basic function of Driver Attention Warning is to warn the driver "**Consider taking a break**".

Taking a break



- The "**Consider taking a break**" message will appear and the inattentive driving (☹️) warning light will blink on the cluster with a warning sound to suggest that the driver take a break, when the driver's attention level is below a certain level.
- Driver Attention Warning will not suggest a break when the total driving time is shorter than 4 minutes or 4 minutes has not passed after the last break was suggested.

! WARNING

For your safety, change the Settings after parking the vehicle at a safe location.

CAUTION

- Driver Attention Warning may suggest a break depending on the driver's driving pattern or habits, even if the driver does not feel fatigue.
 - Driver Attention Warning is a supplemental function and may not be able to determine whether the driver is inattentive.
 - A driver who feels fatigued should take a break at a safe location, even though there is no break suggestion by Driver Attention Warning.
-

Leading Vehicle Departure Alert function

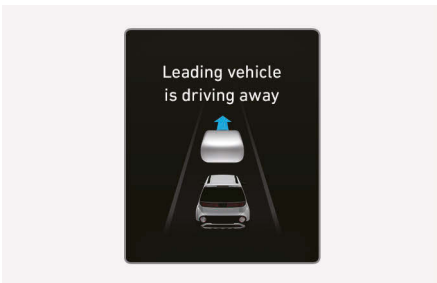

When a detected vehicle in front departs from a stop, Leading Vehicle Departure Alert will inform the driver by displaying the "**Leading vehicle is driving away**" message on the instrument cluster and an audible warning will sound.

WARNING

- If any other system's warning message appears or audible warning is generated, Leading Vehicle Departure Alert's warning message may not be displayed and audible warning may not be generated.
 - The driver has the responsibility to safely drive and control the vehicle.
-

CAUTION

- Leading Vehicle Departure Alert is a supplemental function and may not alert the driver whenever the front vehicle departs from a stop.
 - Always check the front of the vehicle and road conditions before departure.
-

Information

The images and colors in the instrument cluster may differ depending on the cluster type or theme selected in the infotainment system.

Driver Attention Warning malfunction and limitations

Driver Attention Warning malfunction



When Driver Attention Warning is not working properly, the "**Check Inattentive Driving Warning system**" warning message will appear on the cluster for several seconds, and the master (⚠️) warning light and the inattentive driving (☕) warning light will appear on the instrument cluster. If this occurs, we recommend that your vehicle be inspected by an authorized HYUNDAI dealer.

Driver Attention Warning disabled



When the front windshield where the front view camera is located is covered with foreign material, such as snow or rain, it can reduce the detecting performance and temporarily limit or disable Driver Attention Warning. If this occurs, the warning message, the master (⚠️) warning light, and the inattentive driving (☕) warning light will appear on the instrument cluster. Driver Attention Warning will operate properly when snow, rain or foreign material is removed. If Driver Attention Warning does not operate properly after it is removed, we recommend that your vehicle be inspected by an authorized HYUNDAI dealer.

WARNING

- Driver Attention Warning may not properly operate in an area (for example, open terrain) where any objects are not detected right after turning ON the vehicle.
- If the vehicle is turned off and restarted while the camera is blocked or malfunctioned, the condition is maintained. Therefore, Driver Attention Warning may not operate properly.

Limitations of Driver Attention Warning

Driver Attention Warning may not work properly in the following situations:

- The vehicle is driven violently
- The vehicle intentionally crosses over lanes frequently
- The vehicle is controlled by Driver Assistance system, such as Lane Keeping Assist
- Lanes are blurred or erased

Leading Vehicle Departure Alert function

- **When the vehicle cuts in**

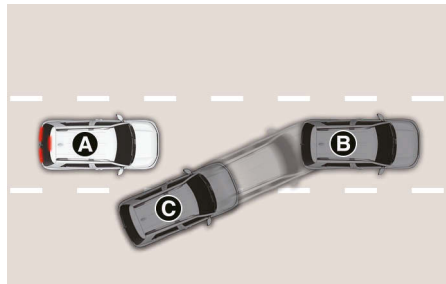
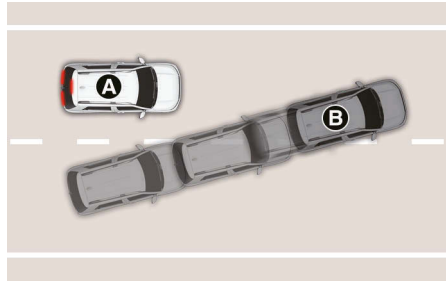

- [A] Your vehicle
- [B] Front vehicle
- [C] Intervening vehicles

If a vehicle cuts in front of your vehicle, Leading Departure Alert may not operate properly.

- **When the vehicle ahead sharply steers**

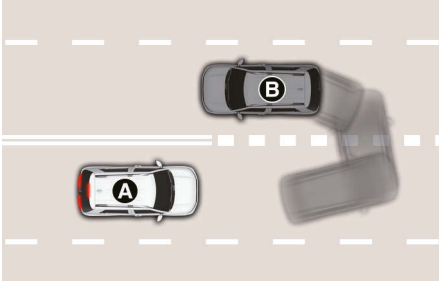

[A] Your vehicle
[B] Front vehicle

If the vehicle in front makes a sharp turn, such as to turn left or right or make a U- turn, etc., Leading Vehicle Departure Alert may not operate properly.

- **When the vehicle ahead abruptly departs**

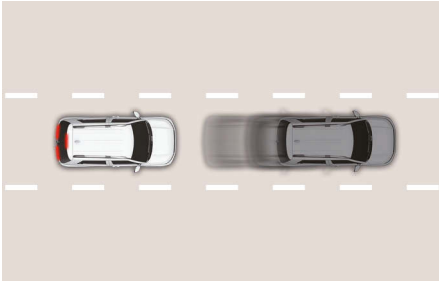

If the vehicle in front abruptly departs, Leading Vehicle Departure Alert may not operate properly.

- **When a pedestrian or bicycle is between you and the vehicle ahead**

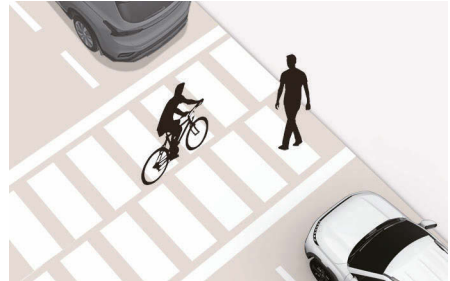

If there is a pedestrian(s) or bicycle(s) in between you and the vehicle in front, Leading Vehicle Departure Alert may not operate properly.

- **When in a parking lot**

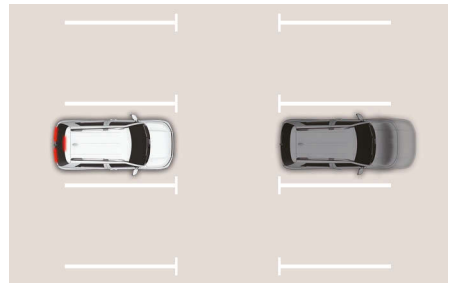

If a vehicle parked in front drives away from you, Leading Vehicle Departure Alert may alert you that the parked vehicle is driving away.

- When driving at a tollgate or intersection, etc.

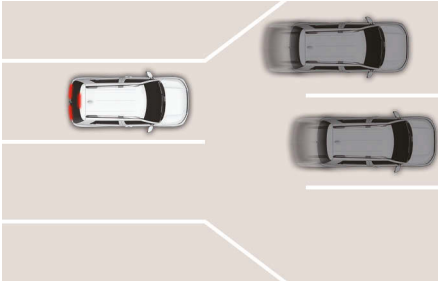

If you pass a tollgate or intersection with lots of vehicles or you drive where lanes are merged or divided frequently, Leading Vehicle Departure Alert may not operate properly.

WARNING

Driver Attention Warning may not operate for about 15 seconds after the vehicle is started, or the front view camera is initialized.

Information

For more information on the precautions of the front view camera, refer to the "Forward Collision-Avoidance Assist (FCA) (Front view camera only)" section in this chapter.

Forward Attention Warning (FAW)

 If equipped

Forward Attention Warning uses the in-cabin camera to help prevent the driver from being distracted while driving with an audible warning and warning light.

Detecting sensor



[A] In-cabin camera

Refer to the picture above for the detailed location of the detecting sensor.

CAUTION

Always keep the in-cabin camera in good condition to maintain optimal performance of Forward Attention Warning.

Forward Attention Warning settings

Forward attention warning

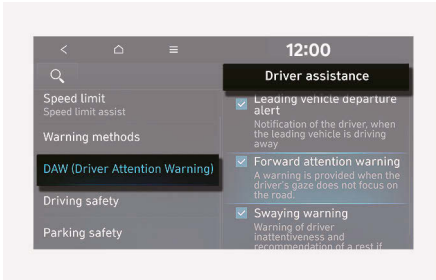

With the vehicle on, select or deselect **Settings > Vehicle > Driver assistance > DAW (Driver Attention Warning) > Forward attention warning** in the infotainment system to set whether to use the function.

If **Forward attention warning** is enabled, the function warns the driver when the driver's gaze is not focused on the road.

i Information

When the vehicle is restarted, Forward Attention Warning maintains the last setting.

Forward Attention Warning operation

Operating conditions

Forward Attention Warning will operate when the following conditions are satisfied:

- Vehicle speed is above 1 mph (1 km/h)
- The gear is in D (Drive) or N (Neutral)

Forward Attention Warning

Forward Attention Warning determines whether the driver is focused on the road depending on information, such as the amount of time the driver is looking elsewhere, the amount of time the eyes are closed, etc. If Forward Attention Warning judges the driver is not focused, an audible warning sounds for about 1 second, and the  warning light appears on the cluster until off conditions are met.

The warning comes on:

- When the driver's gaze is not focused on the road continuously for 3 seconds while driving above 20 km/h (12 mph).
- When the driver's gaze is not focused on the road for 10 seconds or more in total during a 30 seconds time span while driving above 20 km/h (12 mph).
- When the driver's eyes are closed for over 2 seconds or more while driving above 10 km/h (6 mph).

The warning goes off:

When the driver looks forward continuously for over 2 seconds.

Driver Drowsiness Attention Warning



The Driver Drowsiness Attention Warning monitors your eyes while driving. When the driver's eyes are constantly closed or not facing forward frequently, the Driver Drowsiness Attention Warning recommends a break to help with safe driving. The "**Consider taking a break**" warning message and the ☕ warning light appears on the cluster, and an audible warning sounds until the off conditions are met.

The warning comes on:

When the driver's eyes are constantly closed or not facing forward frequently while driving above 10 km/h (6 mph).

The warning goes off:

When the driver's gaze is focused on the road.

⚠ WARNING

If any other system's warning message is displayed or audible warning is generated, Forward Attention Warning's warning message may not be displayed and an audible warning may not be generated.

⚠ CAUTION

- Forward Attention Warning may warn the driver even though the driver is focused on the road because of driving style and driving pattern.
- Forward Attention Warning is a supplemental function and may not determine whether the driver is distracted while driving.
- The driver is responsible for safe driving and must focus on the road.

i Information

- Forward Attention Warning does not transmit recorded videos outside of the vehicle or store the video.
- The Warning methods for Forward Attention Warning can not be changed.

Forward Attention Warning malfunction and limitations

Forward Attention Warning malfunction

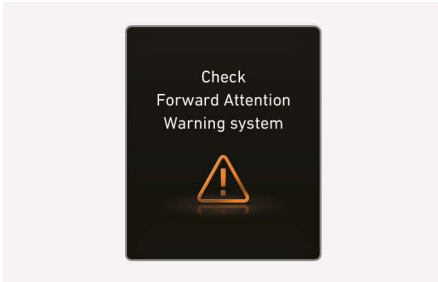

When there is an object right in front of the in-cabin camera or between the driver and the camera for a certain period of time Forward Attention Warning does not operate properly. If this occurs, the "**Check Forward Attention Warning system**" warning message appears on the instrument cluster for several seconds, the  warning light illuminates on the instrument cluster, and an audible warning sounds until the Forward Attention Warning is working properly.

Forward Attention Warning disabled



When there is an object right in front of the in-cabin camera or between the driver and the camera for a certain period of time, Forward Attention Warning does not operate properly, and the "**Forward Attention Warning disabled. Camera obscured**" warning message appears on the instrument cluster, and an audible warning sounds.

If the object is removed or the camera is able to detect the driver's face, the function will operate normally. If Forward Attention Warning does not operate properly after the object is removed, we recommend that your vehicle be inspected by an authorized HYUNDAI dealer.

 **CAUTION**

- Do not impact the surface of the camera or around the camera. If the in-cabin camera is damaged, Forward Attention Warning may not work properly.
 - Do not place anything on the camera or in front of the camera while driving. The in-cabin camera may not operate properly.
 - When cleaning the camera, wipe with a soft and clean cloth to prevent damages on the surface of the camera lens. In addition, you should not use sharp tools near the camera, or use chemicals to clean the camera.
 - Always keep the camera and around the area of the in-cabin camera clean and dry.
 - Do not apply foreign objects, such as a sticker, around the infrared LED located near the camera.
-

 **Information**

Two red lights may appear on the camera in the following conditions when:

- The outside brightness is dim or driving at night
 - The vehicle drives inside a building, such as a basement parking lot, garage or tunnel
 - The camera case is partially broken
-

 **WARNING**

Do not look toward the camera within 8 in. (20 cm) for longer than a minute.

Limitations of Forward Attention Warning

Forward Attention Warning may not operate properly, or it may operate unexpectedly under the following circumstances:

- The driver is wearing sunglasses, special glasses, infrared cutoff glasses, refracting glasses or thick glasses
- The driver has heavy eye makeup (eyeliner, mascara, color makeup, false eyelash) or eye piercing
- The driver's view is blocked by his/her hair, hat, etc.
- The driver is winking or wearing an eye patch on one eye
- The driver's face is covered partially by a mask, muffler, etc.
- The driver's view is blocked by incoming light from outside of the vehicle
- Light from outside, sunlight or infrared LED light of the camera is reflected by glasses or sunglasses
- The driver turns or lowers his/her head so that the face or an eye is hidden from the camera
- The driver shakes his/her head up and down, or adverse road conditions cause excessive vehicle vibrations while driving
- The driver is improperly positioned in the driver's seat so that the driver's face is not detected
- The driver is too tall or short
- The camera is blocked by the driver's grip on the steering wheel
- More than two people are looking at the instrument cluster simultaneously from the driver's seat

- The driver's eyes are narrowed due to laughing or sun glare
- Misrecognize a picture or mannequin that has a similar size of the driver's face
- There are other devices using infrared light in the vehicle

Blind-Spot View Monitor (BVM)

 if equipped

Left



Right



Blind-Spot View Monitor uses the wide-side view cameras to display the rear blind spot areas of your vehicle on the instrument cluster when the turn signal is turned on to help with safe lane changes.

Detecting sensor



(1) Wide-side view camera (camera located at bottom of the mirror)

See the illustration above for the detailed location of the detecting sensors.

Blind-Spot View Monitor settings

Setting features

With the vehicle on, select **Settings > Vehicle > Driver assistance > Driving safety** and then enable **Blind-spot view monitor** in the infotainment system to turn on the Blind-Spot View Monitor feature.

Blind-Spot View Monitor operation

Operating switch

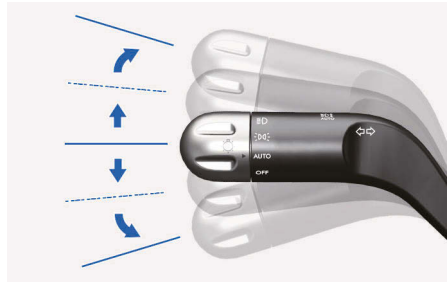

Turn signal switch

Blind-Spot View Monitor will turn on and off when the turn signal is turned on and off.

Blind-Spot View Monitor

Operating conditions

When the left or right side turn signal turns on, the image in that direction is displayed on the instrument cluster.

Off conditions

- When the turn signal turns off, the image on the instrument cluster will turn off.
- When the hazard warning flasher is on, Blind-Spot View Monitor will turn off, regardless of the turn signal status.
- When other important warning is displayed on the instrument cluster, Blind-Spot View Monitor may turn off.

Blind-Spot View Monitor malfunction

When Blind-Spot View Monitor is not working properly, or the cluster display flickers, or the camera image does not display properly, we recommend that your vehicle be inspected by an authorized HYUNDAI dealer.

WARNING

- The image shown on the cluster may differ from the actual distance of the object. Make sure to directly check the vehicle's surroundings for safety.
- Always keep the camera lens clean. If the lens is covered with foreign material, it may adversely affect camera performance and Blind-Spot View Monitor may not operate properly.

Cruise Control (CC)

 if equipped

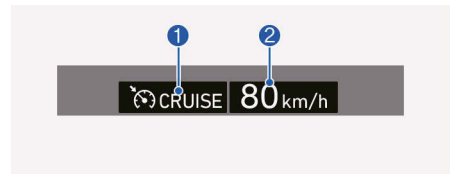

- (1) Cruise indicator
- (2) Set speed

Cruise Control will allow you to drive at speeds above 30 km/h (20 mph) without depressing the accelerator pedal.

Cruise Control operation

Setting speed

1. Accelerate to the desired speed, which must be more than 30 km/h (20 mph).



2. Press the Driving Assist button at the desired speed. The set speed and Cruise (CRUISE) indicator will illuminate on the cluster.
3. Release the accelerator pedal.
Vehicle speed will maintain the set speed even when the accelerator pedal is not depressed.

i Information

- The vehicle may slightly slow down or speed up while driving uphill or downhill.
- The Driving Assist button symbol may vary depending on your vehicle option.

Increasing set speed



- Push the **+** switch up and release it immediately. The set speed will increase by 1 km/h (1 mph) each time the switch is operated in this manner.
- Push the **+** switch up and hold it while monitoring the set speed on the cluster. The set speed will increase to the nearest multiple of 10 km/h (multiple of 5 in mph) at first, and then increase by 10 km/h (5 mph) each time the switch is operated in this manner.

Release the switch when the desired speed is shown and the vehicle will accelerate to that speed.

i Information

The set speed may differ depending on the vehicle specifications. You may not increase the set speed above the maximum set speed.

Decreasing set speed

- Push the **-** switch down and release it immediately. The set speed will decrease by 1 km/h (1 mph) each time the switch is operated in this manner.
- Push the **-** switch down and hold it while monitoring the set speed on the cluster. The set speed will decrease to the nearest multiple of ten (multiple of five in mph) at first, and then decrease by 10 km/h (5 mph) each time the switch is operated in this manner.
Release the switch at the speed you want to maintain.

Accelerating temporarily

If you want to speed up temporarily when Cruise Control is on, depress the accelerator pedal.

To return to the set speed, take your foot off the accelerator pedal.

If you push the **+** switch up or **-** switch down at increased speed, the set speed will be set to the current increased speed.

Temporarily pausing Cruise Control



Cruise Control will be paused when:

- Depressing the brake pedal.
- Pressing the  switch.
- Shifting the gear to N (Neutral).
- Decreasing vehicle speed to less than about 30 km/h (20mph).
- ESC (Electronic Stability Control) is operating.



The set speed will turn off but the Cruise ( CRUISE) indicator will stay on.

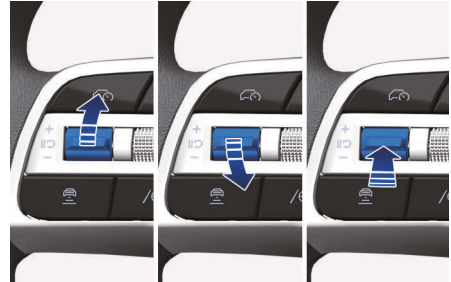

NOTICE

If Cruise Control pauses during a situation that is not mentioned, we recommend that your vehicle be inspected by an authorized HYUNDAI dealer.

Resuming Cruise Control





Operate the ,  or  switch.

If you push the  switch up or  switch down, vehicle speed will be set to the current speed on the cluster.

If you press the  switch, vehicle speed will resume to the preset speed.

The vehicle speed must be above 30 km/h (20 mph) for Cruise Control to resume.

WARNING

Check the driving condition before using the  switch. Driving speed may sharply increase or decrease when you press the  switch.

Turning off Cruise Control



Press the Driving Assist button to turn Cruise Control off. The Cruise (CRUISE) indicator will go off.

Always press the Driving Assist button to turn Cruise Control off when not in use.

i Information

If your vehicle is equipped with Manual Speed Limit Assist, press and hold the Driving Assist button to turn off Cruise Control. However, Manual Speed Limit Assist will turn on.

! WARNING

Take the following precautions when using Cruise Control:

- Always set the vehicle speed under the speed limit in your country.
- Keep Cruise Control off when the system is not in use, to avoid inadvertently setting a speed. Check that the Cruise (CRUISE) indicator is off.
- Cruise Control does not substitute for proper and safe driving. It is the responsibility of the driver to always drive safely and should always be aware of unexpected and sudden situations from occurring.
- Always drive cautiously to prevent unexpected and sudden situations from occurring. Pay attention to the road conditions at all times.
- Do not use Cruise Control when it may be unsafe to keep the vehicle at a constant speed:
 - When driving in heavy traffic, or when traffic conditions make it difficult to drive at a constant speed
 - When driving on rainy, icy, or snow-covered roads
 - When driving on hilly or windy roads
 - When driving in windy areas
 - When driving with limited view (possibly due to bad weather, such as fog, snow, rain and sandstorm)
- Do not use Cruise Control when towing a trailer.

Smart Cruise Control (SCC)

 if equipped

Smart Cruise Control detects a vehicle ahead and helps maintain the distance from the vehicle ahead and the set speed.

Overtaking Acceleration Assist

When Smart Cruise Control judges you are attempting to overtake a vehicle in front, Smart Cruise Control helps with accelerating.

Detecting sensor



- (1) Front view camera
- (2) Front radar

The front view camera and front radar are used as a detecting sensor to detect front vehicles.

See the illustration above for the detailed location of the detecting sensor.

CAUTION

Always keep the front view camera and front radar in good condition to maintain optimal performance of Smart Cruise Control.

For more information on the precautions of the front view camera and front radar, refer to the "Forward Collision-Avoidance Assist (FCA) (Sensor fusion)" section in this chapter.

Smart Cruise Control settings

Smart Cruise Control

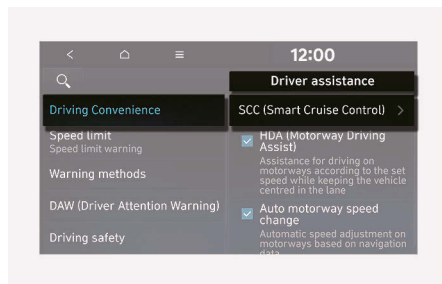

With the vehicle on, select **User Settings > Driver Assistance > Smart Cruise Control** on the instrument cluster or **Settings > Vehicle > Driver assistance > Driving convenience > SCC (Smart Cruise Control)** is selected in the infotainment system, you can change the vehicle distance, the acceleration, and the reaction speed manually.

Warning methods

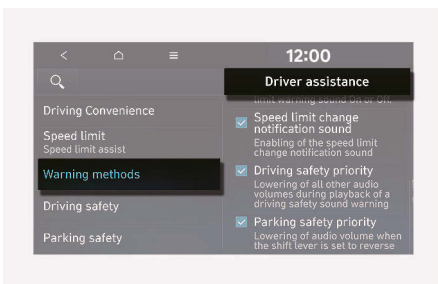
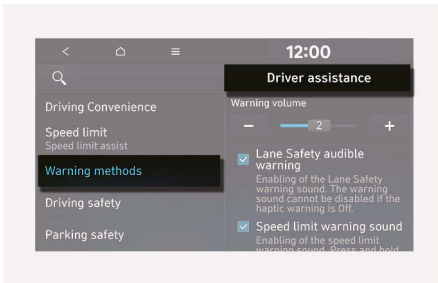

i Information

- If you change the Warning methods, the Warning methods of other Driver Assistance systems may change.
- Warning methods will maintain its last setting even if the vehicle is restarted.
- The setting menu may not be available for your vehicle depending on the vehicle features and specifications.

With the vehicle on, select **User Settings > Driver Assistance > Warning Methods > Warning Volume** on the instrument cluster or **Settings > Vehicle > Driver assistance > Warning methods** in the infotainment system to select following:

- **Warning volume:** The warning volume can be adjusted.
- **Driving safety priority:** Your vehicle lowers all other audio volumes when the Driver Assistance system warning sounds.

Smart Cruise Control operation

Operating conditions

Basic function

Smart Cruise Control operates when the following conditions are satisfied.

- The gear is in D (Drive)
- Your vehicle speed is within the operating speed range
 - 10-140 km/h (5-85 mph): when there is no vehicle in front
 - 0-140 km/h (0-85 mph): when there is a vehicle in front
- ESC (Electronic Stability Control) or ABS (Anti-Lock Braking System) is on

Smart Cruise Control does not operate in the following conditions.

- Your vehicle is in power down mode (⊖ indicator on)
- The driver's door is opened
- EPB (Electronic Parking Brake) is applied
- ESC (Electronic Stability Control) or ABS (Anti-Lock Braking System) is controlling the vehicle
- Forward Collision-Avoidance Assist brake control is operating
- Hands-off warning for Lane Keeping Assist and Highway Driving Assist is on

i Information

When stopped behind another vehicle, the driver can turn on Smart Cruise Control while the brake pedal is depressed.

Operating conditions for Acceleration Assist

Overtaking Acceleration Assist operates when the turn signal indicator is turned on to the left (left-hand drive) or turned on to the right (right-hand drive) while Smart Cruise Control is operating, and the following conditions are satisfied:

- Your vehicle speed is above 60 km/h (40 mph)
- A vehicle is detected in front of your vehicle

Overtaking Acceleration Assist does not operate in the following conditions.

- The hazard warning flasher is on
- Vehicle speed is reduced to maintain distance with the vehicle in front

WARNING

- When the turn signal indicator is turned on to the left (left-hand drive) or turned on to the right (right-hand drive) while there is a vehicle ahead, the vehicle may accelerate temporarily. Pay attention to the road conditions at all times.
- Regardless of the driving direction in your country, Overtaking Acceleration Assist will operate when the conditions are satisfied. When using the function in countries with different driving direction, always check the road conditions at all times.

Turning on Smart Cruise Control



- Press the Driving Assist button to turn on Smart Cruise Control. The speed will be set to the current speed on the cluster.
- If there is no vehicle in front of you, the set speed will be maintained, but if there is a vehicle in front of you, the speed may decrease to maintain the distance to the vehicle ahead. If the vehicle ahead accelerates, your vehicle will travel at a steady cruising speed after accelerating to the set speed.

i Information

If your vehicle speed is between 0-30 km/h (0-20 mph) when you press the Driving Assist button, Smart Cruise Control speed will be set to 30 km/h (20 mph).

Setting vehicle distance



Press the button repeatedly to cycle through the headway settings from

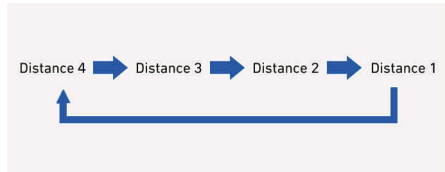

If you drive at 90 km/h (56 mph), the distance is maintained as follows:

- Distance 4: about 52.5 m (172 ft.)
- Distance 3: about 40 m (130 ft.)
- Distance 2: about 32.5 m (106 ft.)
- Distance 1: about 25 m (82 ft.)

i Information

The distance is set to the last set distance when the vehicle is restarted, or when Smart Cruise Control was temporarily canceled.

Increasing set speed



- Push the **+** switch up and release it immediately. The set speed will increase by 1 km/h (1 mph) each time the switch is operated in this manner.
- Push the **+** switch up and hold it while monitoring the set speed on the cluster. The set speed will increase by 10 km/h (5 mph) each time the switch is operated in this manner. Release the switch when the desired speed is shown, and the vehicle will accelerate to that speed. You can increase the set speed up to 140 km/h (85 mph).

WARNING

Check the driving condition before using the **+** switch. Driving speed may sharply increase when you push up and hold the **+** switch.

Decreasing set speed



- Push the **-** switch down and release it immediately. The set speed will decrease by 1 km/h (1 mph) each time the switch is operated in this manner.
- Push the **-** switch down and hold it while monitoring the set speed on the cluster. The set speed will decrease by 10 km/h (5 mph) each time the switch is operated in this manner. Release the switch at the speed you want to maintain. You can decrease the set speed to 30 km/h (20 mph).

Temporarily cancelling Smart Cruise Control



Press the IIⓄ switch or depress the brake pedal to temporarily cancel Smart Cruise Control.

Resuming Smart Cruise Control

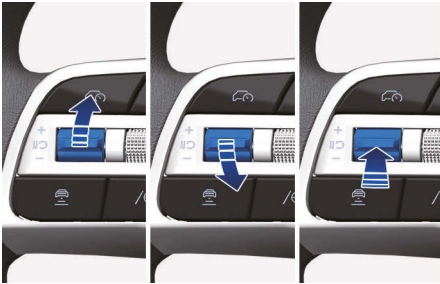

To resume Smart Cruise Control after the function was canceled, operate the +, - or IIⓄ switch.

If you push the + switch up or - switch down, vehicle speed will be set to the current speed on the cluster.

If you press the IIⓄ switch, vehicle speed will resume to the preset speed.

WARNING

Check the driving condition before using the IIⓄ switch. Driving speed may sharply increase or decrease when you press the IIⓄ switch.

Turning off Smart Cruise Control



To turn Smart Cruise Control off, press the Driving Assist (Ⓞ) button.

Information

If your vehicle is equipped with Manual Speed Limit Assist, press and hold the Driving Assist (Ⓞ) button to turn off Smart Cruise Control. However Manual Speed Limit Assist will turn on.

CAUTION

Do not use the switches and buttons at the same time. Smart Cruise Control may not operate properly.

Display and Control

You can see the status of the Smart Cruise Control operation in the Driving Assist view on the cluster. Refer to "Cluster display (Type B)" section in chapter 4.

Smart Cruise Control will be displayed as below depending on the status of the function.

Operating

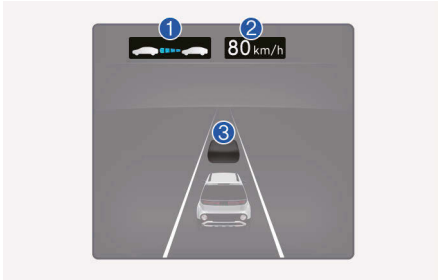

Temporarily canceled

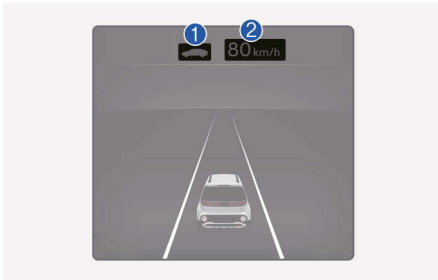

- When operating
 - (1) Whether there is a vehicle ahead and the selected distance level
 - (2) Set speed
 - (3) Whether there is a vehicle ahead and the target vehicle distance

- When temporarily canceled
 - (1) Your vehicle (gray)
 - (2) Previous set speed (gray)

i Information

- The distance of the front vehicle on the cluster is displayed according to the actual distance between your vehicle and the vehicle ahead.
- The target distance may vary according to the vehicle speed and the set distance level. If the vehicle speed is low, even though the vehicle distance have changed, the change of the target vehicle distance may be small.
- The images and colors in the instrument cluster may differ depending on the cluster type or theme selected in the infotainment system.

Accelerating temporarily



If you want to speed up temporarily without altering the set speed while Smart Cruise Control is operating, depress the accelerator pedal. While the accelerator pedal is depressed, the set speed, distance level and target distance will blink on the cluster.

However, if the accelerator pedal is depressed insufficiently, the vehicle may decelerate.

WARNING

Be careful when accelerating temporarily, because the speed and distance is not controlled automatically even if there is a vehicle in front of you.

Temporarily cancelling Smart Cruise Control

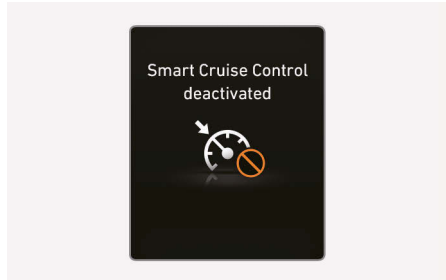

Smart Cruise Control will be temporarily canceled automatically when:

- The vehicle speed is above 150 km/h (90 mph)
- The vehicle is stopped for a certain period of time
- The accelerator pedal is continuously depressed for a certain period of time
- The conditions for the Smart Cruise Control to operate is not satisfied

If Smart Cruise Control is temporarily canceled automatically, the "**Smart Cruise Control deactivated**" warning message will appear on the cluster, and an audible warning will sound to warn the driver.

i Information

If Smart Cruise Control is temporarily canceled while the vehicle is at a standstill with the function activated, EPB (Electronic Parking Brake) maybe applied.

WARNING

When Smart Cruise Control is temporarily canceled, distance with the front vehicle will not be maintained. Always have your eyes on the road while driving, and if necessary, depress the brake pedal to reduce your driving speed in order to maintain a safe distance.

Smart Cruise Control conditions not satisfied

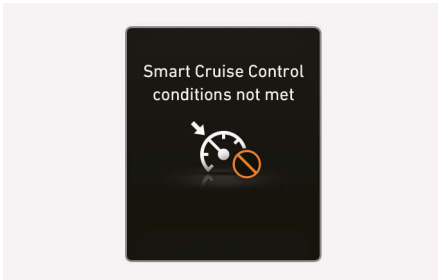

If the Driving Assist button, **+** switch, **-** switch or **||**  switch is operated when Smart Cruise Control operating conditions are not satisfied, the "**Smart Cruise Control conditions not met**" will appear on the cluster, and an audible warning will sound.

In traffic situation

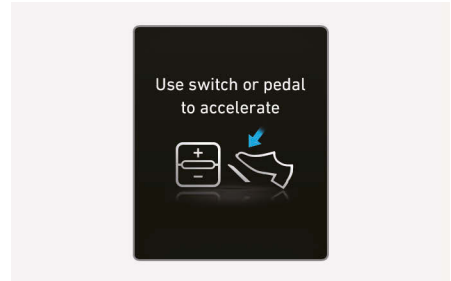

In traffic, your vehicle will stop if the vehicle ahead of you stops. Also, if the vehicle ahead of you starts moving, your vehicle will start as well. In addition, after the vehicle has stopped and a certain time have passed, the "**Use switch or pedal to accelerate**" message will appear on the instrument cluster. Depress the accelerator pedal or operate the **+** switch, **-** switch or **||**  switch to start driving.

Warning road conditions ahead



In the following situation, the **"Watch for surrounding vehicles"** warning message will appear on the cluster, and an audible warning will sound to warn the driver of road conditions ahead.

- The vehicle in front disappears when Smart Cruise Control is maintaining the distance with the vehicle ahead while driving below a certain speed.

WARNING

Always pay attention to vehicles or objects that may suddenly appear in front of you, and if necessary, depress the brake pedal to reduce your driving speed in order to maintain a safe distance.

Collision Warning



While Smart Cruise Control is operating, when the collision risk with the vehicle ahead is high, Forward Collision-Avoidance Assist will operate to warn the driver. Always have your eyes on the road while driving, and if necessary, depress the brake pedal to reduce your driving speed in order to maintain a safe distance.

For more information on this function, refer to "Forward Collision-Avoidance Assist (FCA) (Sensor fusion)" section in this chapter.

WARNING

Take the following precautions when using Smart Cruise Control:

- Smart Cruise Control does not substitute for proper and safe driving. It is the responsibility of the driver to always check the speed and distance to the vehicle ahead.
- Smart Cruise Control may not recognize unexpected and sudden situations or complex driving situations, so always pay attention to driving conditions and control your vehicle speed.
- Keep Smart Cruise Control off when the function is not in use to avoid inadvertently setting a speed.

- Do not open the door or leave the vehicle when Smart Cruise Control is operating, even if the vehicle is stopped.
- Always be aware of the selected speed and headway distance.
- Keep a safe distance according to road conditions and vehicle speed. If the headway distance is too close during high-speed driving, a serious collision may result.
- When maintaining distance with the vehicle ahead, if the front vehicle disappears, Smart Cruise Control may suddenly accelerate to the set speed. Always be aware of unexpected and sudden situations from occurring.
- Vehicle speed may decrease on an upward slope and increase on a downward slope.
- Always be aware of situations such as when a vehicle cuts in suddenly.
- When you are towing a trailer or another vehicle, turn off Smart Cruise Control for safety reasons.
- Turn off Smart Cruise Control when your vehicle is being towed.
- Smart Cruise Control may not operate properly if interfered by strong electromagnetic waves.
- Smart Cruise Control may not detect an obstacle in front and lead to a collision. Always look ahead cautiously to prevent unexpected and sudden situations from occurring.
- Vehicles moving in front of you with a frequent lane change may cause a delay in Smart Cruise Control reaction or may cause Smart Cruise Control to react to a vehicle actually in an adjacent lane. Always drive cautiously to prevent unexpected and sudden situations from occurring.
- Always be aware of the surroundings and drive safely, even though a warning message does not appear or an audible warning does not sound.
- If any other system's warning message appears or warning sound is generated, Smart Cruise Control warning message may not be displayed and warning sound may not be generated.
- You may not hear the warning sound of Forward Collision-Avoidance Assist if the surrounding is noisy.
- The vehicle manufacturer is not responsible for any traffic violation or accidents caused by the driver.
- Always set the vehicle speed under the speed limit in your area.

i Information

- Smart Cruise Control may not operate for few seconds after the vehicle is started or the front view camera or front radar is initialized.
- You may hear a sound when the brake is controlled by Smart Cruise Control.

Smart Cruise Control malfunction and limitations

Smart Cruise Control malfunction

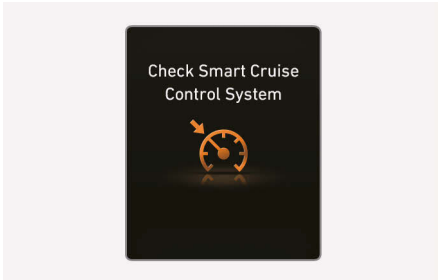

When Smart Cruise Control is not working properly, the "**Check Smart Cruise Control System**" warning message and the master (⚠) warning light will appear on the instrument cluster. We recommend that your vehicle be inspected by an authorized HYUNDAI dealer.

Smart Cruise Control disabled

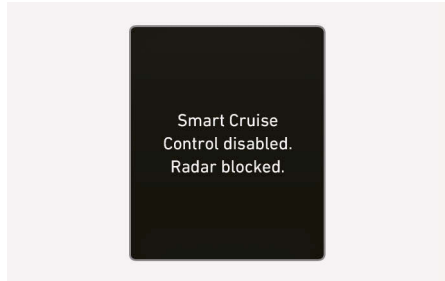

When the front radar cover or sensor is covered with snow, rain, or foreign material, it can reduce the detecting performance and temporarily limit or disable Smart Cruise Control.

If this occurs the warning message will appear for a certain period of time on the instrument cluster.

Smart Cruise Control will operate properly when snow, rain or foreign material is removed.

WARNING

Even though the warning message does not appear on the cluster, Smart Cruise Control may not properly operate.

CAUTION

Smart Cruise Control may not properly operate in an area (for example, open terrain), where there is nothing to detect after turning ON the vehicle.

Limitations of Smart Cruise Control

Smart Cruise Control may not operate properly, or it may operate unexpectedly under the following circumstances:

- The detecting sensor or the surroundings are contaminated or damaged
- Washer fluid is continuously sprayed, or the wiper is on
- The camera lens is contaminated due to tinted, filmed or coated windshield, damaged glass, or sticky foreign material (sticker, bug, etc.) on the glass
- Moisture is not removed or frozen on the windshield
- The field of view of the front view camera is obstructed by sun glare
- Street light or light from an oncoming vehicle is reflected on the wet road surface, such as a puddle on the road
- The temperature around the front view camera is high or low
- An object is placed on the dashboard
- The surrounding is very bright
- The surrounding is very dark, such as in a tunnel, etc.
- The brightness changes suddenly, for example when entering or exiting a tunnel
- The brightness outside is low, and the headlights are not on or are not bright
- Driving in heavy rain or snow, or thick fog
- Driving through steam, smoke or shadow
- Only part of the vehicle is detected
- The vehicle in front has no tail lights, tail lights are located unusually, etc.
- The brightness outside is low, and the tail lights are not on or are not bright
- The rear of the front vehicle is small or does not look normal (for example, tilted, overturned, etc.)
- The front vehicle's ground clearance is low or high
- A vehicle suddenly cuts in front
- Your vehicle is being towed
- Driving through a tunnel or iron bridge
- Driving near areas containing metal substances, such as a construction zone, railroad, etc.
- An object reflecting off the front radar such as a guardrail, nearby vehicle, etc.
- The bumper around the front radar is impacted, damaged or the front radar is out of position
- The temperature around the front radar is high or low
- Driving in vast areas where there are few vehicles or structures (for example, desert, meadow, suburb, etc.)
- The vehicle in front is made of material that does not reflect on the front radar
- Driving near a highway (or motorway) interchange or tollgate
- Driving on a slippery surface due to snow, water puddle, ice, etc.
- Driving on a curved road
- The vehicle in front is detected late
- The vehicle in front is suddenly blocked by an obstacle
- The vehicle in front suddenly changes lane or suddenly reduces speed
- The vehicle in front is bent out of shape
- The front vehicle's speed is fast or slow

- With a vehicle in front, your vehicle changes lane at low speed
- The vehicle in front is covered with snow
- Unstable driving
- You are on a roundabout and the vehicle in front is not detected
- You are continuously driving in a circle
- Driving in a parking lot
- Driving through a construction area, unpaved road, partial paved road, uneven road, speed bumps, etc.
- Driving on an incline road, curved road, etc.
- Driving through a roadside with trees or streetlights
- The adverse road conditions cause excessive vehicle vibrations while driving
- Your vehicle height is low or high due to heavy loads, abnormal tire pressure, etc.
- Driving through a narrow road where trees or grass are overgrown
- There is interference by electromagnetic waves, such as driving in an area with strong radio waves or electrical noise

• Driving on a curved road

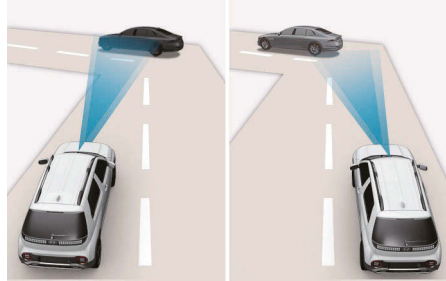

On curves, Smart Cruise Control may not detect a vehicle in the same lane, and may accelerate to the set speed. Also, vehicle speed may rapidly decrease when the vehicle ahead is detected suddenly.

Select the appropriate set speed on curves and apply the brake pedal or accelerator pedal according to the road and driving conditions ahead.

Your vehicle speed can be reduced due to a vehicle in the adjacent lane.

Apply the accelerator pedal and select the appropriate set speed. Check to be sure that the road conditions permit safe operation of the Smart Cruise Control.

- Driving on an inclined road

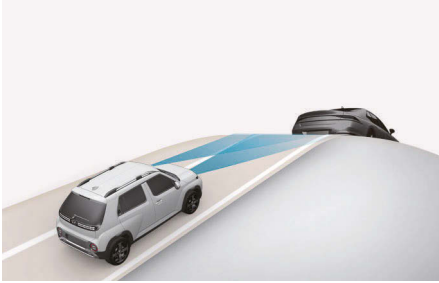

During uphill or downhill driving, the Smart Cruise Control may not detect a moving vehicle in your lane, and cause your vehicle to accelerate to the set speed. Also, vehicle speed will rapidly decrease when the vehicle ahead is detected suddenly.

Select the appropriate set speed on inclines and apply the brake pedal or accelerator pedal according to the road and driving conditions ahead.

- Changing lanes

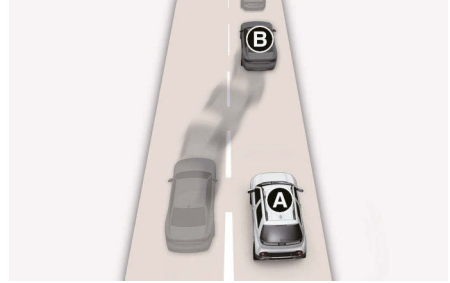

[A] Your vehicle

[B] Lane changing vehicle

When a vehicle moves into your lane from an adjacent lane, it cannot be detected by the sensor until it is in the sensor's detection range. Smart Cruise Control may not immediately detect the vehicle when the vehicle changes lanes abruptly. In this case, you must maintain a safe braking distance, and if necessary, depress the brake pedal to reduce your driving speed in order to maintain a safe distance.

• Situations when detecting are limited

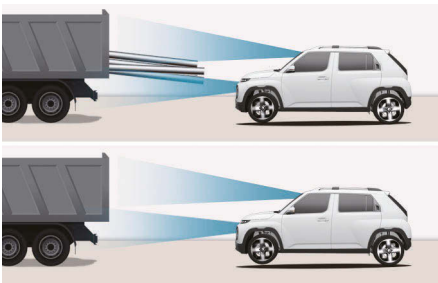
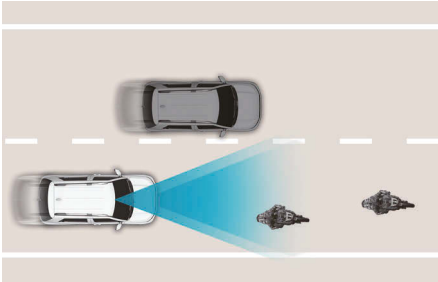

In the following cases, some vehicles, pedestrians or animals in your lane cannot be detected by the sensor:

- Vehicles offset to one side
- Slow-moving vehicles or sudden decelerating vehicles
- Vehicles with higher ground clearance or vehicles carrying loads that stick out of the back of the vehicle
- Vehicles that has the front lifted due to heavy loads
- Vehicles within about 2 m (6 ft.) from your vehicle
- Oncoming vehicles
- Stopped vehicles
- Vehicles with small rear profile, such as trailers
- Narrow vehicles, such as motorcycles or bicycles

- Special vehicles
 - Animals and pedestrians
 - Adjust your vehicle speed by depressing the brake pedal according to the road and driving conditions ahead.
- Adjust your vehicle speed by depressing the brake pedal according to the road and driving conditions ahead.
- In the following cases, the vehicle in front cannot be detected by the sensor:
- You are steering your vehicle
 - Driving on narrow or sharply curved roads
- When a vehicle ahead disappears at an intersection, your vehicle may accelerate.

Always pay attention to road and driving conditions while driving.

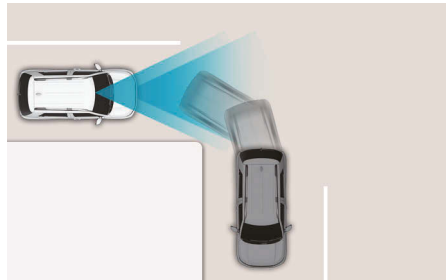

- When a vehicle in front of you merges out of the lane, Smart Cruise Control may not immediately detect the new vehicle that is now in front of you.

Always pay attention to road and driving conditions while driving.

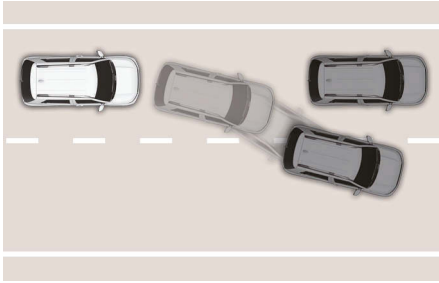

- Always look out for pedestrians when your vehicle is maintaining a distance with the vehicle ahead.

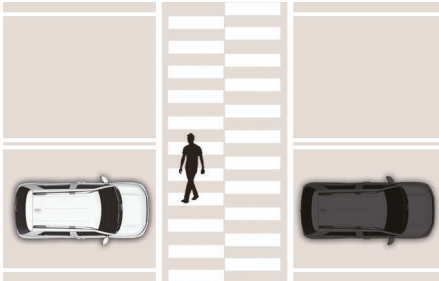

Navigation-Based Smart Cruise Control (NSCC)

+ if equipped

Navigation-based Smart Cruise Control can help drive at a certain speed according to the road conditions when driving on highways by using road information from the navigation system while Smart Cruise Control is operating.

i Information

- Navigation-based Smart Cruise Control is available only on certain highways.
- Navigation-based Smart Cruise Control operates on main roads of highways (or motorways), and does not operate on interchanges or junctions.
- Additional highways may be expanded by future navigation updates.

Highway Curve Zone Auto Slowdown

If vehicle speed is high, Highway Curve Zone Auto Slowdown function will temporarily decelerate your vehicle or limit acceleration to help you drive safely on a curve based on the curve information from the navigation.

Navigation-based Smart Cruise Control Settings

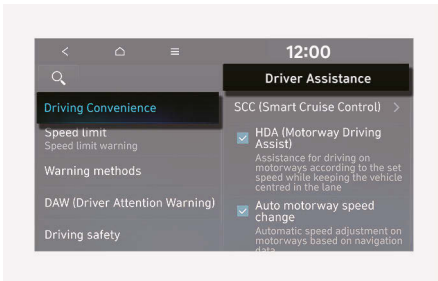

With the vehicle on, select **Settings > Vehicle > Driver assistance > Driving convenience > Auto motorway speed change** from the infotainment system to turn on Navigation-based Smart Cruise Control and deselect to turn off the function.

i Information

When there is a problem with Navigation-based Smart Cruise Control, the function cannot be set in the infotainment system.

Navigation-based Smart Cruise Control Operation

Operating conditions

Navigation-based Smart Cruise Control is ready to operate if all of the following conditions are satisfied:

- Select **Auto motorway speed change** from the infotainment system.
- Smart Cruise Control is operating
- Driving on main roads of highways

i Information

For more information on how to operate Smart Cruise Control, refer to the "Smart Cruise Control (SCC)" section in this chapter.

Navigation-based Smart Cruise Control display and control

When Navigation-based Smart Cruise Control operates, it will be displayed on the instrument cluster as follows:



Navigation-based Smart Cruise Control standby

If the operating conditions are satisfied, the green **NAV** indicator light (1) illuminates.

Navigation-based Smart Cruise Control operating

While the speed is being controlled, the green **NAV** indicator light (1) blinks.

Temporarily canceled or interrupted by the driver

If Navigation-based Smart Cruise Control cannot control the vehicle, such as when Smart Cruise Control is temporarily canceled or the navigation system is searching for a route, the gray **NAV** indicator light (1) illuminates.

When the driver depresses the accelerator pedal, the white **NAV** indicator light (1) blinks.

WARNING



"**Drive carefully**" warning message will appear in the following circumstances:

- Navigation-based Smart Cruise Control is not able to slow down your vehicle to a safe speed

i Information

The images and colors in the instrument cluster may differ depending on the instrument cluster type or theme selected from the infotainment system.

Highway Curve Zone Auto Slowdown

Depending on the curve ahead on the highway, the vehicle will decelerate, and after passing the curve, the vehicle will accelerate to Smart Cruise Control set speed.

i Information

Vehicle deceleration time may differ depending on the vehicle speed and the degree of the curve on the road. The higher the driving speed, deceleration will start faster.

Limitations of Navigation-based Smart Cruise Control

Navigation-based Smart Cruise Control may not operate properly under the following circumstances:

- The navigation is not working properly
- Map information is not transmitted due to infotainment system's abnormal operation
- Speed limit and road information in the navigation is not updated
- The map information and the actual road is different because of real-time GPS data or map information error
- The navigation searches for a route while driving
- GPS signals are blocked in areas such as a tunnel
- A road that divides into two or more roads and joins again
- The driver goes off course from the route set in the navigation
- The route to the destination is changed or canceled by resetting the navigation
- Android Auto or Car Play is operating
- The navigation cannot detect the current vehicle position (for example, elevated roads including overpass adjacent to general roads or nearby roads exist in a parallel way)
- The navigation is being updated while driving
- The navigation is being restarted while driving
- The speed limit of some sections changes according to the road situations

- Driving on a road under construction
- Driving in lane-restricted driving situations
- There is bad weather, such as heavy rain, heavy snow, etc.
- Driving on a road that is sharply curved

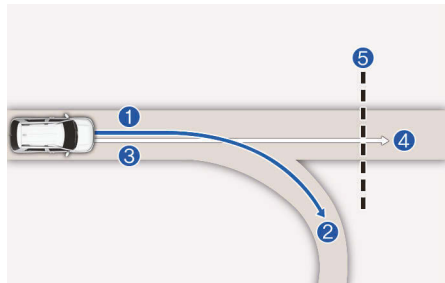

- (1) Set route
- (2) Branch line
- (3) Driving route
- (4) Main road
- (5) Curved road section

- When there is a difference between the navigation set route (branch line) and the driving route (main road), Highway Curve Zone Auto Slowdown function may not operate until the driving route is recognized as the main road.
- When the vehicle's driving route is recognized as the main road by maintaining the main road instead of the navigation set route, Highway Curve Zone Auto Slowdown function will operate. Depending on the distance to the curve and the current vehicle speed, vehicle deceleration may not be sufficient or may decelerate rapidly.

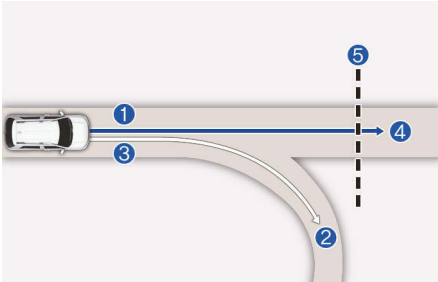

- (1) Set route
- (2) Branch line
- (3) Driving route
- (4) Main road
- (5) Curved road section

- When there is a difference between the navigation route (main road) and the driving route (branch line), Highway Curve Zone Auto Slowdown function will operate based on the curve information on the main road.
- When it is judged that you are driving out of the route by entering the highway interchange or junction, Highway Curve Zone Auto Slowdown function will not operate.

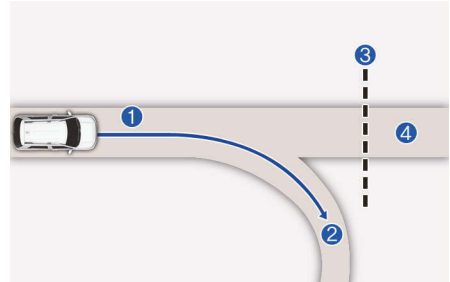

- (1) Driving route
- (2) Branch line
- (3) Curved road section
- (4) Main road

- If there is no destination set on the navigation, Highway Curve Zone Auto Slowdown function will operate based on the curve information on the main road.
- Even if you depart from the main road, Highway Curve Zone Auto Slowdown function may temporarily operate due to navigation information of the highway curve section.

WARNING

- Navigation-based Smart Cruise Control is not a substitute for safe driving practices, but a convenience function. Always have your eyes on the road, and it is the responsibility of the driver to avoid violating traffic laws.
 - The navigation's speed limit information may differ from the actual speed limit information on the road. It is the driver's responsibility to check the speed limit on the actual driving road or lane.
 - Navigation-based Smart Cruise Control will automatically be canceled when you leave the highway main road. Always pay attention to road and driving conditions while driving.
 - Navigation-based Smart Cruise Control may not operate due to the existence of leading vehicles and the driving conditions of the vehicle. Always pay attention to road and driving conditions while driving.
 - When you are towing a trailer or another vehicle, turn off Navigation-based Smart Cruise Control for safety reasons.
 - After you pass through a tollbooth on a highway, Navigation-based Smart Cruise Control will operate based on the first lane. If you enter one of the other lanes, Navigation-based Smart Cruise Control might not operate properly.
 - The vehicle will accelerate if the driver depresses the accelerator pedal while Navigation-based Smart Cruise Control is operating, and the function will not decelerate the vehicle. However, if the accelerator pedal is depressed insufficiently, the vehicle may decelerate.
 - If the driver accelerates and releases the accelerator pedal while Navigation-based Smart Cruise Control is operating, the vehicle may not decelerate sufficiently or may rapidly decelerate to a safe speed.
 - If the curve is too large or too small, Navigation-based Smart Cruise Control may not operate.
-

Information

- A time gap could occur between the navigation's guidance and when Navigation-based Smart Cruise Control operation starts and ends.
 - The speed information on the instrument cluster and navigation may differ.
 - Even if you are driving at a speed lower than Smart Cruise Control set speed, acceleration may be limited by the curve sections ahead.
 - If Navigation-based Smart Cruise Control is operating while leaving the main road to enter an interchange, junction, rest area, etc., the function may operate for a certain period of time.
 - Deceleration by Navigation-based Smart Cruise Control may feel it is not sufficient due to road conditions such as uneven road surfaces, narrow lanes, etc.
-

Lane Following Assist (LFA)

Lane Following Assist detects lane markings and/or a vehicle ahead on the road, and center your vehicle in the lane.

Detecting sensor



(1) Front view camera

The front view camera is used as a detecting sensor to detect lane markings and front vehicles.

See the illustration above for the detailed location of the detecting sensor.

CAUTION

For more information on the precautions of the front view camera, refer to the "Forward Collision-Avoidance Assist (FCA) (Front view camera only)" section in this chapter.

Lane Following Assist settings

WARNING

When the vehicle and the trailer is connected electrically, a warning message appears on the cluster, and Lane Following Assist is deactivated. The function resumes after the trailer connector is disconnected. (if Hyundai genuine part equipped)

Warning methods

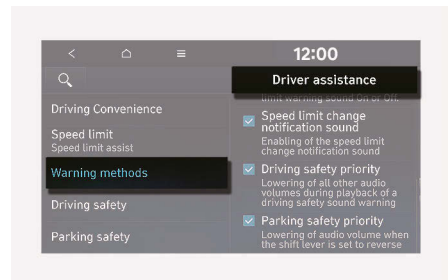
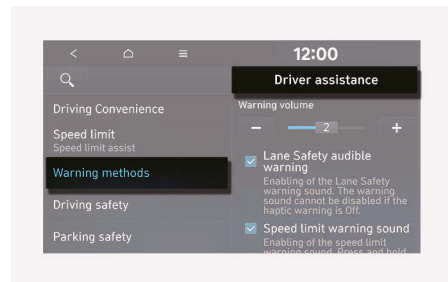

With the vehicle on, select **User Settings** > **Driver Assistance** > **Warning Methods** > **Warning Volume** on the instrument cluster or **Settings** > **Vehicle** > **Driver assistance** > **Warning methods** in the infotainment system to select following:

- **Warning volume:** The warning volume can be adjusted.

- **Driving safety priority:** Your vehicle lowers all other audio volumes when the Driver Assistance system warning sounds.

i Information

- If you change the Warning methods, the Warning methods of other Driver Assistance systems may change.
- Warning methods will maintain its last setting even if the vehicle is restarted.
- The setting menu may not be available for your vehicle depending on the vehicle features and specifications.

Lane Following Assist operation

Turning Lane Following Assist On/Off



With the vehicle on, shortly press the Lane Driving Assist button located on the steering wheel to turn on Lane Following Assist. The gray or green (⊕) indicator light will appear on the cluster.

Press the button again to turn off the function.

Lane Following Assist



If the vehicle ahead and/or both lane markings are detected and your vehicle speed is below 140 km/h (85 mph), the green (⊕) indicator light appears on the cluster, and Lane Following Assist helps center the vehicle in the lane by assisting the steering wheel.

⚠ CAUTION

When the steering wheel is not assisted, the white (⊕) indicator light blinks and changes to gray.

Hands-off warning



If the driver takes their hands off the steering wheel for several seconds, the "**Keep hands on steering wheel**" warning message will appear with a warning sound in stages.

- First stage: Warning message
- Second stage: Warning message (red steering wheel) with a warning sound

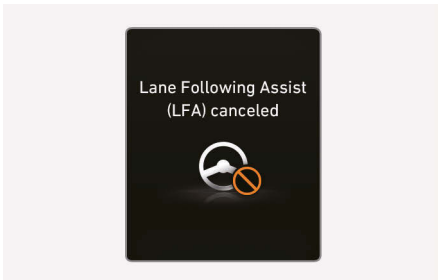

If the driver still does not have their hands on the steering wheel after the hands-off warning, the "**Lane Following Assist (LFA) canceled**" warning message will appear and Lane Following Assist will be automatically canceled.

WARNING

- The steering wheel may not be assisted if the steering wheel is held very tight or the steering wheel is steered over a certain degree.
- Lane Following Assist does not operate at all times. It is the responsibility of the driver to safely steer the vehicle and to maintain the vehicle in its lane.
- The hands-off warning message may appear late depending on road conditions. Always have your hands on the steering wheel while driving.
- If you wear the gloves or the steering wheel is held very lightly the hands-off warning message may appear because Lane Following Assist may not recognize that the driver has their hands on the steering wheel.
- If you attach objects to the steering wheel, the hands-off warning may not work properly.

i Information

- For more information on instrument cluster settings, refer to the "Cluster display (Type B)" section in chapter 4.
- When both lane markings are detected, the lane lines on the cluster will change from gray to white.

Lane undetected/detected

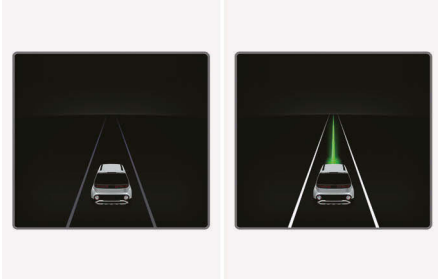

- The images and colors in the instrument cluster may differ depending on the cluster type or theme selected in the infotainment system.
- If lane markings are not detected, steering wheel control by Lane Following Assist can be limited depending on whether a vehicle is in front or the driving conditions of the vehicle.
- Even though the steering is assisted by Lane Following Assist, the driver may control the steering wheel.
- The steering wheel may feel heavier or lighter when the steering wheel is assisted by Lane Following Assist than when it is not.

Lane Following Assist malfunction and limitations

Lane Following Assist malfunction

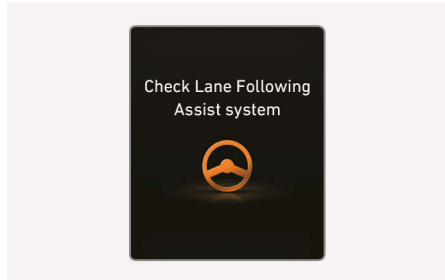

When Lane Following Assist is not working properly, the **"Check Lane Following Assistance system"** warning message will appear on the instrument cluster for several seconds, and the master (⚠) warning light appears on the instrument cluster. If this occur, we recommend that your vehicle be inspected by an authorized HYUNDAI dealer.

Limitations of Lane Following Assist

For more information on Lane Following Assist limitations, refer to the "Lane Keeping Assist (LKA)" section in this chapter.

i Information

For more information on Lane Following Assist precautions, refer to the "Lane Keeping Assist malfunction and limitations" section in this chapter.

! WARNING

Loading in excess of the maximum load allowance or concentrated loading at one point in the cargo compartment can reduce the vehicle's driving stability, which can in turn reduce the effectiveness of Lane Following Assist.

Highway Driving Assist (HDA)

+ if equipped

Highway Driving Assist

Highway Driving Assist helps maintain a set distance and speed from the vehicle ahead while driving on a highway main section and helps center the vehicle in the lane.

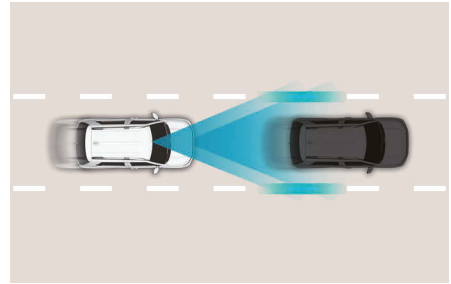

Detecting sensor

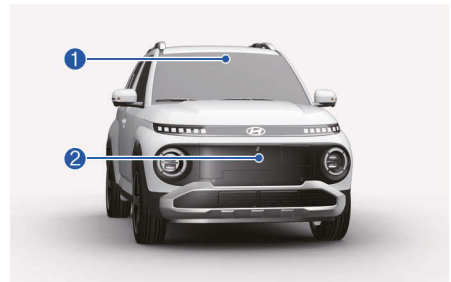

- (1) Front view camera
- (2) Front radar

Refer to the picture above for the detailed location of the detecting sensors.

CAUTION

For more information on the precautions of the detecting sensors, refer to the "Forward Collision-Avoidance Assist (FCA) (Sensor fusion)" section in this chapter.

Highway Driving Assist Settings

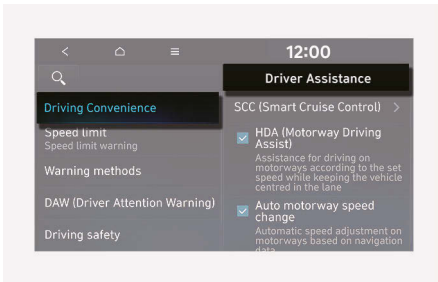

With the vehicle on, select or deselect **Settings > Vehicle > Driver assistance > Driving convenience > HDA (Motorway Driving Assist)** from the infotainment system to set whether to use each function.

If **HDA (Motorway Driving Assist)** is selected, it helps maintain distance from the vehicle ahead, maintain the set speed, and helps center the vehicle in the lane.

Basic function

If **HDA (Motorway Driving Assist)** is selected, it helps maintain distance from the vehicle ahead, maintain the set speed, and helps center the vehicle in the lane.

Information

- If there is a problem with the functions, the settings cannot be changed. We recommend that your vehicle be inspected by an authorized HYUNDAI dealer.
 - If the vehicle is restarted, the functions will maintain the last setting.
-

WARNING

For your safety, only change the Settings after parking the vehicle at a safe location.

WARNING

When the vehicle and the trailer is connected electrically, a warning message appears on the cluster, and Highway Driving Assist is deactivated. The function resumes after the trailer connector is disconnected. (if Hyundai genuine part equipped)

Warning methods

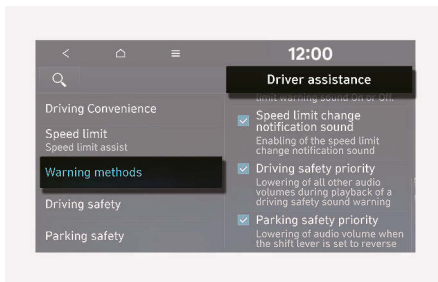
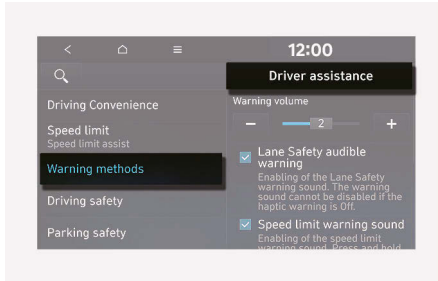

With the vehicle on, select **Settings > Vehicle > Driver assistance > Warning methods** in the infotainment system to select following:

- **Warning volume:** The warning volume can be adjusted.
- **Driving safety priority:** Your vehicle lowers all other audio volumes when the Driver Assistance system warning sounds.

i Information

- If you change the Warning methods, the Warning methods of other Driver Assistance systems may change.
- Warning methods will maintain its last setting even if the vehicle is restarted.
- The setting menu may not be available for your vehicle depending on the vehicle features and specifications.

Highway Driving Assist Operation

Basic function

Displaying operating status

You can see the status of the Highway Driving Assist operation in the Driving Assist view on the instrument cluster. For more information, refer to the "Cluster display (Type B)" section in chapter 4.

Highway Driving Assist will be displayed as below depending on the status of the function.

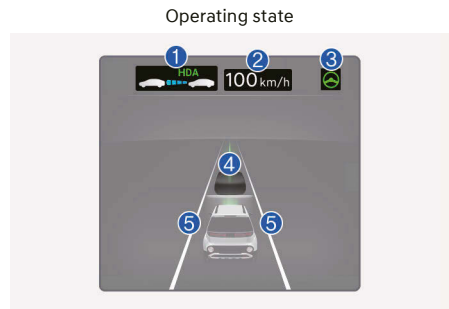

Standby state



1. Highway Driving Assist indicator, whether there is a vehicle ahead and the selected distance level are displayed.
 - Highway Driving Assist (HDA) indicator light
 - Green HDA: Operating state
 - Gray HDA: Standby state
 - White HDA blink: Accelerator depressed state
 - Not displayed : Off
2. Set speed
3. Lane Following Assist indicator
4. Whether there is a vehicle ahead and the selected headway
5. Whether the lane is detected or not

i Information

- For more information on the display refer to the "Smart Cruise Control (SCC)" and "Lane Following Assist (LFA)" sections in this chapter.
- The images and colors in the instrument cluster may differ depending on the instrument cluster type or theme selected from infotainment system.

Highway Driving Assist operation

Highway Driving Assist operates when:

- Driving on the main road of highways, and turning on Highway Driving Assist by pressing the Driving Assist button
- Entering the main road of highways while Lane Following assist and Smart Cruise Control are operating

Restarting after stopping

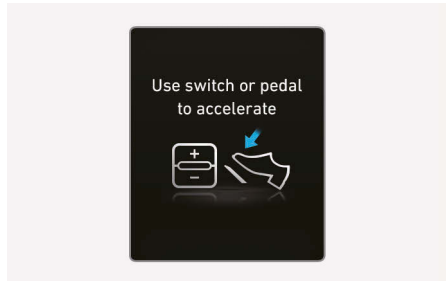

When Highway Driving Assist is operating, your vehicle will stop if the vehicle ahead of you stops. Also, if the vehicle ahead of you starts moving within 30 seconds after the stop, your vehicle will start as well. In addition, after the vehicle has stopped and 30 seconds have passed, the "**Use switch or pedal to accelerate**" message will appear on the instrument cluster. Depress the accelerator pedal or operate the **+** switch, **-** switch or **II** switch to start driving.

Hands-off warning



If the driver takes their hands off the steering wheel for several seconds, the "**Keep hands on steering wheel**" warning message will appear and an audible warning will sound in stages.

- First stage: Warning message
- Second stage: Warning message (red steering wheel) and audible warning



If the driver still does not have their hands on the steering wheel after the hands-off warning, "**Highway Driving Assist deactivated**" warning message will appear and Highway Driving Assist will be automatically canceled.

Driving speed limit



When Highway Driving Assist is canceled by the hands-off warning, The driving speed will be limited.

While Driving Speed Limit function is operating, the "**Driver's grasp not detected. Driving speed will be limited**" warning message will appear on the instrument cluster, and an audible warning will sound continuously.

Highway Driving Assist standby

When the Smart Cruise Control is temporarily canceled while Highway Driving Assist is operating, Highway Driving Assist will be in the standby state. At this time, Lane Following Assist will operate properly.

i Information

- Driving Speed Limit helps you drive below 60 km/h (40 mph). At this time, the vehicle decelerates due to the vehicle ahead. After the vehicle has decelerated, it cannot automatically accelerate.
- Driving Speed Limit will cancel in the following circumstances:
 - When the driver grabs the steering wheel again
 - When the driver turns on Lane Following Assist by pressing the Lane Driving Assist button (/⊕\)
 - When +, -, II⊙ switch or ⊞ button is operated, or the accelerator pedal or the brake pedal is depressed

Highway Driving Assist Malfunction and Limitations

Highway Driving Assist malfunction



When Highway Driving Assist is not working properly, the "**Check Highway Driving Assistance system.**" warning message and the master (⚠) warning light appears on the instrument cluster. If this occurs, we recommend that your vehicle be inspected by an authorized HYUNDAI dealer.

! WARNING

- The driver is responsible for controlling the vehicle and safe driving.
- Always have your hands on the steering wheel while driving.
- Highway Driving Assist is a supplemental function that assists the driver in driving the vehicle and is not a complete autonomous driving system. Always check road conditions, and if necessary, take appropriate actions to drive safely.
- Always have your eyes on the road, and it is the responsibility of the driver to avoid violating traffic laws. The vehicle manufacturer is not responsible for any traffic violation or accidents caused by the driver.
- Highway Driving Assist may not be able to recognize all traffic situations. Highway Driving Assist may not detect possible collisions due to limitations of the function. Always be aware of the limitations of the function. Obstacles such as vehicles, motorcycles, bicycles, pedestrians, or unspecified objects or structures such as guardrails, tollbooth, etc., that may collide with the vehicle may not be detected.
- Highway Driving Assist will turn off automatically under the following situations:
 - Driving on roads that Highway Driving Assist does not operate, such as a rest area, intersection, junction, etc.
 - The navigation does not operate properly such as when the navigation is being updated or restarted

- Highway Driving Assist may inadvertently operate or turn off depending on road conditions (navigation information) and surroundings.
 - Lane Following Assist function may be temporarily disabled when the front view camera cannot detect lanes properly or the hands-off warning is on.
 - You may not hear the warning sound of Highway Driving Assist if the surrounding is noisy.
 - If the vehicle is driven at high speed above a certain speed at a curve, your vehicle may drive to one side or may depart from the driving lane.
 - When you are towing a trailer or another vehicle, turn off Highway Driving Assist for safety reasons.
 - The hands-off warning message may appear early or late depending on how the steering wheel is held or road conditions. Always have your hands on the steering wheel while driving.
 - For your safety, please read the owner's manual before using the Highway Driving Assist.
 - Highway Driving Assist will not operate when the vehicle is started, or when the detecting sensors or navigation is being initialized.
-

Limitation of Highway Driving Assist

Highway Driving Assist may not operate properly, or may not operate under the following circumstances:

- The map information and the actual road is different because the navigation is not updated
- The map information and the actual road is different because of real-time GPS data or map information error
- The infotainment system is overloaded by simultaneously performing functions such as route search, video playback, voice recognition, etc.
- GPS signals are blocked in areas such as a tunnel
- The driver goes off course or the route to the destination is changed or canceled by resetting the navigation
- The vehicle enters a service station or rest area
- Android Auto or Car Play is operating
- The navigation cannot detect the current vehicle position (for example, elevated roads including overpass adjacent to general roads or nearby roads exist in a parallel way)

***i* Information**

For more information on the limitations of the front view camera, front radar refer to the "Forward Collision-Avoidance Assist (FCA) (Sensor fusion)" and "Blind-Spot Collision-Avoidance Assist (BCA)" section in this chapter.

Rear View Monitor (RVM)

 If equipped

Rear View Monitor shows the area behind the vehicle to assist you when parking or driving.

Information

If the display audio or the navigation of HYUNDAI genuine parts is applied, the description of the rear view monitor may differ from the owner's manual.

In this case, check the setup and operation method of the rear view monitor by accessing the web manual with the QR code in the separately supplied simple manual.

Detecting sensor

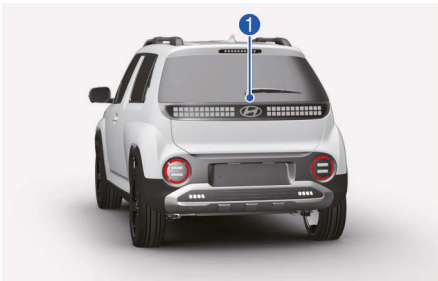

(1) Wide-rear view camera

Refer to the picture above for the detailed location of the detecting sensor.

Rear View Monitor settings

Warning methods

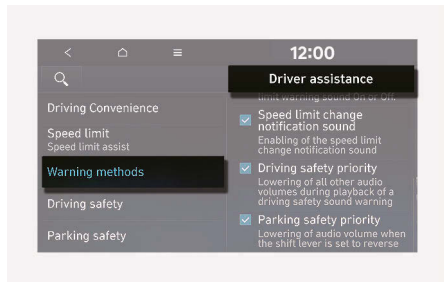
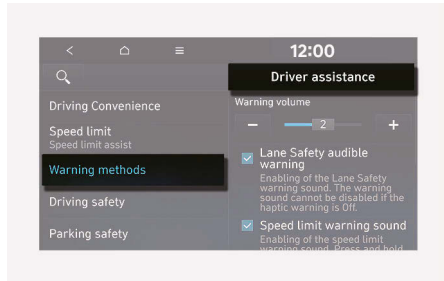

With the vehicle on, select **Settings > Vehicle > Driver assistance > Warning methods** in the infotainment system to select following:

- **Parking safety priority:** Your vehicle lowers all other audio volumes when Rear View Monitor is operating.

i Information

- If you change the Warning methods, the Warning methods of other Driver Assistance systems may change.
- Warning methods will maintain its last setting even if the vehicle is restarted.
- The setting menu may not be available for your vehicle depending on the vehicle features and specifications.

Camera settings

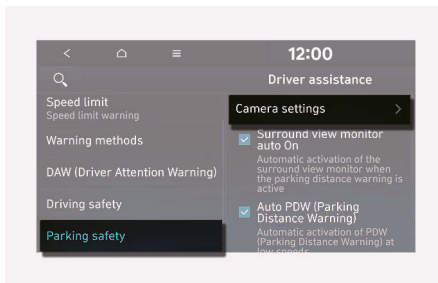

You can change Rear View Monitor "**Display contents**" by touching the setup icon (⚙️) on the screen while Rear View Monitor is operating, or by selecting **Settings > Vehicle > Driver assistance > Parking safety > Camera settings** in the infotainment system while the vehicle is on.

Extend rear camera use

Keeps displaying the rear view when shifting from R (Reverse) to N (Neutral) or D (Drive).

Rear view reference lines

If **Rear view parking lines** is selected, the rear view parking guide lines and rear top view guide lines will be displayed in the infotainment system screen.

Display setting

Adjust the brightness(day/night) of the camera screen and its contrast.

i Information

- The horizontal guideline of the Rear View Parking Guidance is based on the absence of a driver in a vehicle. shows the distance of 0.5 m (20 in.), 1 m (40 in.) and 2.3 m (91 in.) from the vehicle.
- The horizontal guideline of the Rear Top View Parking guideline is based on the absence of a driver in a vehicle. This shows the distance of 0.5 m (20 in.), 1.5 m (60 in.) from the vehicle.
- The setting menu may not be available for your vehicle depending on the vehicle features and specifications.

Rear View Monitor operation

Parking/View button

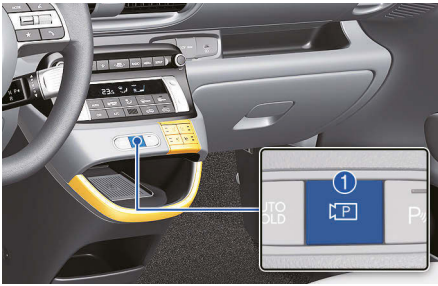

Press the Parking/View button (1) while the gear is in P (Park), D (Drive) or N (Neutral) to turn on the Rear View Monitor.

Rear view



Operating conditions

- The gear is shifted to R (Reverse).
- Touch the Change View button (2) to select rear view or rear top view.

Off conditions

- The gear is shifted to P (Park).
- The gear is shifted to N (Neutral) or D (Drive).

i Information

When the gear is in R (Reverse), the rear view does not turn off.

Extended Rear View Monitor

When Rear View Monitor is selected to remain on, the Rear View Monitor will keep displaying when driving below 10 km/h (6 mph).

Operating conditions

- When pressing Parking/View button while the gear is shifted to N (Neutral) or D (Drive).
- When pressing Parking/View button while the gear is shifted to P (Park)
- You can select the Rear Top View or Rear View by pressing the View shift button (2) when the Rear View is on.

Off conditions

- When vehicle speed is above 10 km/h (6 mph), the rear view will turn off.
- Shift the gear to P (Park), the rear view will turn off.
- Press the Parking/View button (1), the rear view will turn off.
- When infotainment system button (4) is selected.
- When home button (3) of the Rear view is selected.

Rear View while driving

The driver is able to check the rear view on the screen while driving.

Operating conditions

The Parking/View button (1) is pressed, while the gear is in N (Neutral) or D (Drive), and the vehicle speed is above 10 km/h (6 mph)

Off conditions

- The gear is shifted to P (Park).
- The Parking/View button (1) is pressed again.
- One of the infotainment system button (4) is selected.
- The Infotainment system screen button (3) is selected on the rear view menu.

When operating

If the gear is shifted to R (Reverse), when rear view while driving appears on the screen, the screen will change to rear view.

i Information

- The rear view does not turn off regardless of the mode when the gear is in R (Reverse).
- Always display the rear view when the gear is shifted to R (Reverse).
- The rear parking guidelines are displayed in rear view and rear top view mode. (When selecting **Settings > Vehicle > Driver assistance > Parking safety > Camera settings > Display contents > Rear view reference lines** in the infotainment system) However, rear parking guidelines are not displayed in the rear view while driving.
- The rear view while driving does not turn off even when the vehicle speed is lower than 10 km/h (6 mph) once it is on.
- When the rear view while driving is on, the rear top view will be deactivated.

Rear View Monitor malfunction and limitations

Rear View Monitor malfunction

When Rear View Monitor is not working properly, or the screen flickers, or the camera image does not display properly, we recommend that your vehicle be inspected by an authorized HYUNDAI dealer.

Limitations of Rear View Monitor

When your vehicle is stopped for a long time in winter or your vehicle is parked in an indoor parking lot, the exhaust fumes may temporarily blur the image.

⚠ WARNING

- The rear view camera does not cover the complete area behind the vehicle. The driver should always check the rear area directly through the inside and outside rearview mirror before parking or backing up.
- The distance to the object shown on the screen may differ from the actual distance. This is because the image shown on Rear View Monitor is displayed by calibrating the image from the wide-rear view camera.

When the vehicle is tilted by cargo loading, parking guidelines may not be correct. Make sure to directly check the vehicle's surroundings for safety.

- Always keep the rear view camera lens clean. If the lens is covered with foreign material, it may adversely affect camera performance and Rear View Monitor may not operate properly. However, do not use chemical solvents such as strong detergents containing high alkaline or volatile organic solvents (gasoline, acetone, etc.). This may damage the camera lens.

Surround View Monitor (SVM)

+ If equipped

Surround View Monitor uses the wide view cameras and displays images around your vehicle through the infotainment system screen to help with safe parking or driving.

Detecting sensor

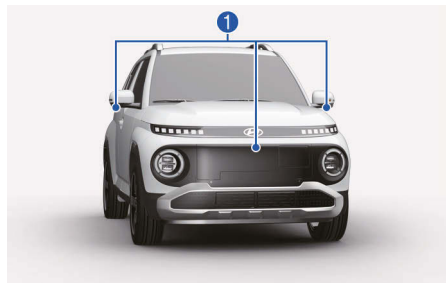

- (1) Wide-front/side view camera
- (2) Wide-rear view camera

Refer to the picture above for the detailed location of the detecting sensors.

Surround View Monitor settings

Warning methods

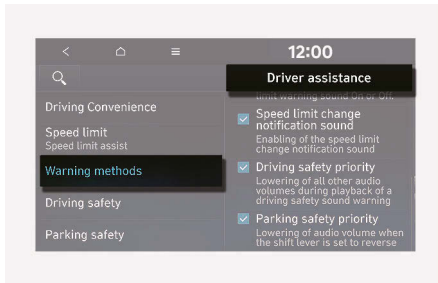
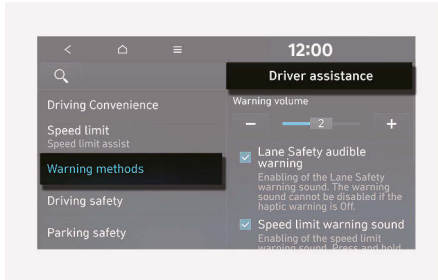

With the vehicle on, select on the instrument cluster or **Settings > Vehicle > Driver assistance > Warning methods** in the infotainment system to select following:

- **Parking safety priority:** Your vehicle lowers all other audio volumes when Surround View Monitor is operating.

i Information

- If you change the Warning methods, the Warning methods of other Driver Assistance systems may change.
- Warning methods will maintain its last setting even if the vehicle is restarted.
- The setting menu may not be available for your vehicle depending on the vehicle features and specifications.

Camera settings

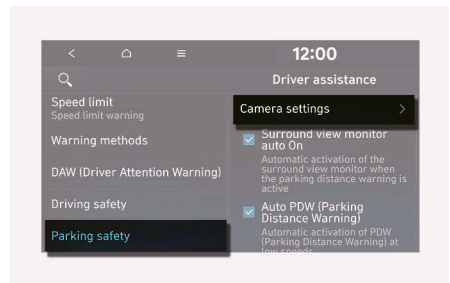

You can change Surround View Monitor "**Display contents**" by touching the setup icon (⚙️) on the screen while Surround View Monitor is operating, or by selecting **Settings > Vehicle > Driver assistance > Parking safety > Camera settings** in the infotainment system while the vehicle is on.

You can adjust the brightness(day/night) of the camera screen and its contrast.

Surround view monitor auto On

With the vehicle on, select **Settings > Vehicle > Driver assistance > Parking safety > Surround view monitor auto On** in the infotainment system to use the function.

Auto PDW (Parking Distance Warning)

When the **Auto PDW (Parking Distance Warning)** is selected, parking distance warning appears on the top view of the Surround View Monitor screen.

i Information

- The horizontal guideline of the Rear Top View Parking Guidance shows the distance of 0.5 m (20 in.), 2 m (79 in.) from the vehicle.
- The horizontal guideline shows the distance of 0.5 m (20 in.), 1 m (40 in.) and 2.3 m (91 in.).
- The setting menu may not be available for your vehicle depending on the vehicle features and specifications.

Surround View Monitor operation

Parking/View button



Press the Parking/View button (1) to turn on Surround View Monitor.

Press the button again to turn off the function.

Front view



The front view appears on the screen when the gear is in N (Neutral) or D (Drive) to assist in parking.

You may select top view, front view, and side view using the change view button (2).

Operating conditions

- The gear is shifted to N (Neutral) or D (Drive) from R (Reverse) and the vehicle speed is 10 km/h (6 mph) or less.
- The Parking/View button (1) is pressed, while the gear is in N (Neutral) or D (Drive), and vehicle speed is 10 km/h (6 mph) or less.
- The Parking Distance Warning operates when the gear is shifted to D (Drive). select **Driver assistance > Parking safety > Surround view monitor auto On** in the infotainment system.

i Information

When the front view is activated, the latest used view mode is displayed.

Off conditions

- The gear is shifted from N (Neutral) or D (Drive) to P (Park).
- The Parking/View button (1) or the Infotainment system button (4) is Pressed.
- Vehicle speed is above 10 km/h (6 mph).
- The Home button (3) is pressed.

Rear view



The rear view appears on the screen to assist in parking.

You may select top view, rear view, and side view using the change view button (2).

Operating conditions

- The gear is shifted to R (Reverse).
- The rear view is selected by pressing the Parking/View button (1), while the gear is in P (Park).

Off conditions

- The gear is shifted to P (Park).
- The Home button (3) is pressed.
- The Parking/View button (1) is pressed.
- The Infotainment system screen button (4) is pressed.

i Information

When the gear is in R (Reverse), the rear view does not turn off even if the infotainment system button (4) is Pressed.

Rear View while driving

The driver is able to check the rear view on the screen while driving, it is to assist with backing up.

Operating conditions

- You can turn on the Surround View Monitor by pressing the Parking/View button (1) when vehicle speed is above 10 km/h (6 mph) and the gear is shifted to N (Neutral) or D (Drive).
- Press Parking/View button (1) when vehicle speed is above 10 km/h (6 mph). When driving below 10 km/h (6 mph), press rear view shift button (2) on the Surround View Monitor.
- Press the rear view button when vehicle's speed drops below 10 km/h (6 mph) and the front view is turned on. Press the view shift button (2) to select the rear wide view or rear view while driving.
- You may select rear wide view or rear view using the change view button (2).

Off conditions

- The gear is shifted to P (Park).
- The Parking/View button (1) is pressed.
- The Infotainment system screen button (4) is pressed.
- The Home button (3) is pressed.
- When driving below 10 Km/h, press the other view mode button (2) on the surround view monitor.
- Press the home button (2) on the surround view monitor.

i Information

- When the rear view while driving is activated, the latest used view mode is displayed.
 - The Rear View Parking Lines does not operate on the rear view while driving.
 - The rear view while driving does not turn off even when the vehicle speed is lower than 10 km/h (6 mph) once it is on.
-

3D view

The 3D view shows the image around the vehicle from various angles.

You can change angles by tapping the screen. Press the 3D view button again to return to the initial angle.

Operating conditions

When the 3D view is selected by pressing the change view button (2):

- The gear is in P (Park), N (Neutral) or D (Drive) when vehicle speed is below 10 km/h (6 mph).
- The Surround View Monitor is turned on when the gear is in R (Reverse).

Off conditions

When the gear is in P (Park), N (Neutral) or D (Drive):

- The gear is shifted to P (Park) from N (Neutral) or D (Drive).
- The Parking/View button (1) or the Infotainment system button (4) is Pressed.
- Vehicle speed is above 10 km/h (6 mph).

When the gear is in R (Reverse):

- The gear is shifted to P (Park)

i Information

3D view does not display guidelines.

Surround View Monitor malfunction and limitations

Surround View Monitor malfunction

When Surround View Monitor is not working properly, or the screen flickers, or the camera image does not display properly, we recommend that your vehicle be inspected by an authorized HYUNDAI dealer.

Limitations of Surround View Monitor

The screen may be displayed abnormally, and an icon may appear at the top left side of the screen under the following circumstances:

- The tailgate is opened
- The driver or front passenger door is opened
- The outside rearview mirror is folded

! WARNING

- ALWAYS look around your vehicle to make sure there are no objects or obstacles before moving the vehicle. What you see on the screen may differ from the actual vehicle's location.
- The distance to the object shown on the screen may differ from the actual distance. This is because the image shown on Surround View Monitor is displayed by calibrating the image from the camera.

When the vehicle is tilted by cargo loading, parking guidelines may not be correct. Make sure to directly check the vehicle's surroundings for safety.

- Surround View Monitor is designed to be used on a flat surface. Therefore, if used on roads with different heights such as curbs and speed bumps, the image in the screen may not look correct.
- Always keep the camera lens clean. If the lens is covered with foreign material, it may adversely affect camera performance and Surround View Monitor may not operate properly. However, do not use chemical solvents such as strong detergents containing high alkaline or volatile organic solvents (gasoline, acetone, etc.). This may damage the camera lens.

i Information

Surround View Monitor uses the cameras installed on the vehicle to show images around the vehicle through the infotainment system screen. The image shown on the screen may look unnatural depending on the surroundings.

Rear Cross-Traffic Collision-Avoidance Assist (RCCA)

 If equipped

Rear Cross-Traffic Collision-Avoidance Assist detects vehicles approaching from the rear left or right while your vehicle is reversing and warns you of a possible collision with a warning message and a warning sound. Also, Rear Cross-Traffic Collision-Avoidance Assist may assist with braking your vehicle to help avoid a collision.

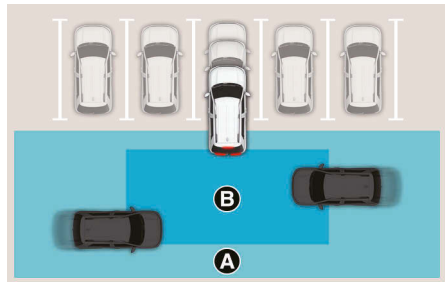

- [A] Rear Cross-Traffic Collision Warning operating range
- [B] Rear Cross-Traffic Collision-Avoidance Assist operating range

CAUTION

Warning timing may vary depending on the speed of the approaching vehicle.

Detecting sensor



(1) Rear corner radar

Refer to the picture above for the detailed location of the detecting sensors.

i Information

For more information on the precautions of the rear corner radar, refer to the "Blind-Spot Collision-Avoidance Assist (BCA)" section in this chapter.

Rear Cross-Traffic Collision-Avoidance Assist settings

Rear cross-traffic safety

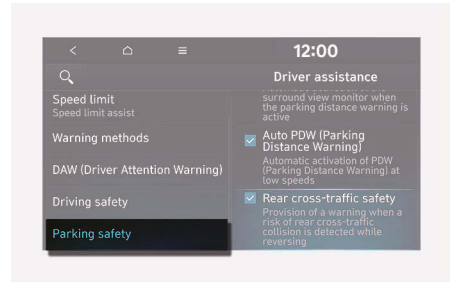

With the vehicle on, select **User settings > Driver Assistance > Parking Safety > Rear Cross-Traffic Safety** in the instrument cluster or **Settings > Vehicle > Driver assistance > Parking safety > Rear cross-traffic safety** in the infotainment system to turn on Rear Cross-Traffic Collision-Avoidance Assist and deselect to turn off the function.

WARNING

When the vehicle is restarted, Rear Cross-Traffic Collision-Avoidance Assist always turn on. However, if **Rear cross-traffic safety** is deselected after the vehicle is restarted, the driver should always be aware of the surroundings and drive safely.

Warning methods

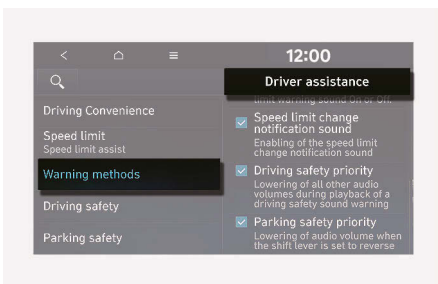
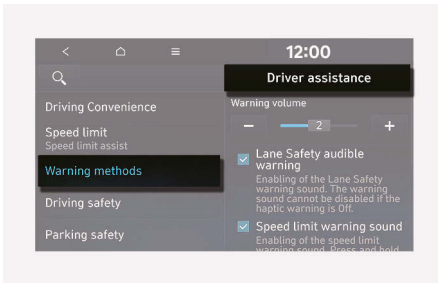

With the vehicle on, select **User Settings** > **Driver Assistance** > **Warning Methods** > **Warning Volume** on the instrument cluster or **Settings** > **Vehicle** > **Driver assistance** > **Warning methods** in the infotainment system to select following:

- **Warning volume:** The warning volume can be adjusted.

i Information

- If you change the Warning methods, the Warning methods of other Driver Assistance systems may change.
- Warning methods will maintain its last setting even if the vehicle is restarted.
- The setting menu may not be available for your vehicle depending on the vehicle features and specifications.

Rear Cross-Traffic Collision-Avoidance Assist operation

Rear Cross-Traffic Collision-Avoidance Assist warns and helps control the vehicle depending on collision risk level: 'Collision Warning', 'Emergency Braking' and 'Stopping vehicle and ending brake control'.

Collision Warning

- To warn the driver of an approaching vehicle from the rear left/right side of your vehicle, the warning light on the outside rearview mirror will blink and a warning will appear on the instrument cluster. At the same time, an audible warning will sound, and the steering wheel will vibrate. If Rear View Monitor is operating, a warning will also appear on the infotainment system screen.
- Rear Cross-Traffic Collision-Avoidance Assist will operate when all the following conditions are satisfied:
 - The gear is shifted to R (Reverse)
 - Vehicle speed is below 8 km/h (5 mph)
 - The approaching vehicle is within about 25 m (82 ft.) from the left and right side of your vehicle
 - The speed of the vehicle approaching from the left and right is above 5 km/h (3 mph)

i Information

- If the operating conditions are satisfied, there may be a warning whenever the vehicle approaches from the left or right side even though your vehicle speed is 0 km/h (0 mph).
- The images and colors in the instrument cluster may differ depending on the cluster type or theme selected in the infotainment system.

Emergency Braking



- To warn the driver of an approaching vehicle from the rear left/right side of your vehicle, the warning light on the outside rearview mirror blinks and a warning message appears on the instrument cluster. At the same time, an audible warning sounds. A warning also appears on the infotainment system.
- Emergency braking will be assisted to help prevent a collision with approaching vehicles from the left and right.

- Rear Cross-Traffic Collision-Avoidance Assist operates when all the following conditions are satisfied:
 - The gear is shifted to R (Reverse)
 - Vehicle speed is below 8 km/h (5 mph)
 - The approaching vehicle is within about 1.5 m (5 ft.) from the left and right side of your vehicle
 - The speed of the vehicle approaching from the left and right is above 5 km/h (3 mph)
 - Emergency braking is assisted to help prevent collision with approaching vehicles from the left and right.

WARNING

Brake control will end when:

- The approaching vehicle is out of the detecting range
- The approaching vehicle passes behind your vehicle
- The approaching vehicle does not drive toward your vehicle
- The approaching vehicle speed slows down
- The driver depresses the brake pedal with sufficient power

Stopping vehicle and ending brake control



- When the vehicle is stopped due to emergency braking, the **"Drive carefully"** warning message will appear on the cluster.
- For your safety, the driver should depress the brake pedal immediately and check the surroundings.
- Brake control will end after the vehicle is stopped by emergency braking for about 2 seconds.
- During emergency braking, braking control by Rear Cross-Traffic Collision-Avoidance Assist will automatically cancel when the driver excessively depresses the brake pedal.

WARNING

Take the following precautions when using Rear Cross-Traffic Collision-Avoidance Assist:

- For your safety, only change the Settings after parking the vehicle at a safe location.
- If any other system's warning message appears or audible warning is generated, Rear Cross-Traffic Collision-Avoidance Assist warning message may not be displayed and audible warning may not be generated.
- You may not hear the warning sound of Rear Cross-Traffic Collision-Avoidance Assist if the surrounding is noisy.
- Rear Cross-Traffic Collision-Avoidance Assist may not operate if the driver applies the brake pedal to avoid collision.
- During Rear Cross-Traffic Collision-Avoidance Assist operation, the vehicle may stop suddenly injuring passengers and shifting loose objects. Always have the seat belt on and keep loose objects secured.
- Even if there is a problem with Rear Cross-Traffic Collision-Avoidance Assist, the vehicle's basic braking performance will operate properly.
- When Rear Cross-Traffic Collision-Avoidance Assist is operating, braking control by the function will automatically cancel when the driver excessively depresses the accelerator pedal.
- Rear Cross-Traffic Collision-Avoidance Assist does not operate in all situations or cannot avoid all collisions.
- Rear Cross-Traffic Collision-Avoidance Assist may warn the driver late or may not warn the driver depending on the road and driving conditions.

- The driver has the responsibility to control the vehicle. Do not solely depend on Rear Cross-Traffic Collision-Avoidance Assist. Rather, maintain a safe braking distance, and if necessary, depress the brake pedal to reduce driving speed or to stop the vehicle.
- Never deliberately operate Rear Cross-Traffic Collision-Avoidance Assist on people, animal, objects, etc. It may cause serious injury or death.

CAUTION

The brake control may not operate properly depending on the status of ESC (Electronic Stability Control).

There will only be a warning when:

- The ESC (Electronic Stability Control) warning light is on
- ESC (Electronic Stability Control) is engaged in a different function

Information

If braking is assisted by Rear Cross-Traffic Collision-Avoidance Assist, the driver must immediately depress the brake pedal and check vehicle surroundings.

- Brake control will end when the driver depresses the brake pedal with sufficient power.
- After shifting the gear to R (Reverse), braking control will operate once for left and right vehicle approach.

Rear Cross-Traffic Collision-Avoidance Assist malfunction and limitations

Rear Cross-Traffic Collision-Avoidance Assist malfunction

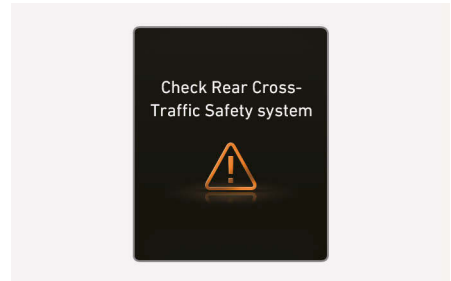

When Rear Cross-Traffic Collision-Avoidance Assist is not working properly, the "**Check Rear Cross-Traffic Safety system**" warning message appears on the instrument cluster for several seconds, and the master () warning light illuminates on the instrument cluster. If this occur, we recommend that your vehicle be inspected by an authorized HYUNDAI dealer.

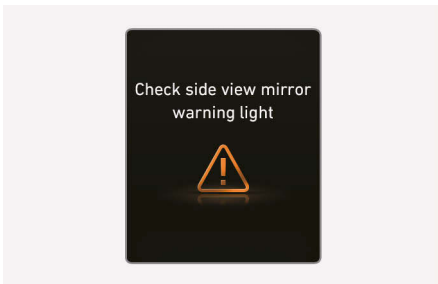

When the outside rearview mirror warning light is not working properly, the "Check side view mirror warning light" warning message appears on the instrument cluster for several seconds, and the master (⚠) warning light illuminates on the cluster. If this occur, we recommend that your vehicle be inspected by an authorized HYUNDAI dealer.

Rear Cross-Traffic Collision-Avoidance Assist disabled



When the rear bumper around the rear-side radar or sensor is covered with foreign material, such as snow or rain, or installing a trailer or carrier, it can reduce the detecting performance and temporarily limit or disable Rear Cross-Traffic Collision-Avoidance Assist.

If this occurs, the "**Rear Cross-Traffic Safety system disabled. Radar blocked.**" warning message appears on the instrument cluster.

Rear Cross-Traffic Collision-Avoidance Assist operates properly when such foreign material or trailer, etc., is removed.

If Rear Cross-Traffic Collision-Avoidance Assist does not operate properly after it is removed, we recommend that your vehicle be inspected by an authorized HYUNDAI dealer.

⚠ WARNING

- Even though the warning message does not appear on the cluster, Rear Cross-Traffic Collision-Avoidance Assist may not operate properly.
- Rear Cross-Traffic Collision-Avoidance Assist may not operate properly in an area (for example, open terrain), where any objects are not detected after turning ON the vehicle.

⚠ CAUTION

Turn off Rear Cross-Traffic Collision-Avoidance Assist to install or remove a trailer, carrier, or another attachment. Turn on Rear Cross-Traffic Collision-Avoidance Assist when finished.

Limitations of Rear Cross-Traffic Collision-Avoidance Assist

Rear Cross-Traffic Collision-Avoidance Assist may not operate properly, or it may operate unexpectedly under the following circumstances:

- Departing from where trees or grass are overgrown
- Departing from where roads are wet
- Speed of the approaching vehicle is fast or slow

Braking control may not work, driver's attention is required in the following circumstances:

- The vehicle severely vibrates while driving over a bumpy road, uneven road or concrete patch
- Driving on a slippery surface due to snow, water puddle, ice, etc.
- The tire pressure is low or a tire is damaged
- The braking system has been modified
- Remote Smart Parking Assist is operating (if equipped)

***i* Information**

For more information on the limitations of the rear corner radar, refer to the "Blind-Spot Collision-Avoidance Assist (BCA)" section in this chapter.

! WARNING

- **Driving near a vehicle or structure**

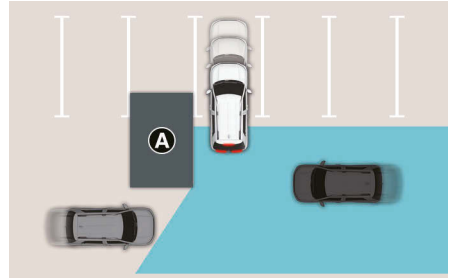

[A] Structure

Rear Cross-Traffic Collision-Avoidance Assist may be limited when driving near a vehicle or structure, and may not detect the vehicle approaching from the left or right. If this occurs, the function may not warn the driver or control the brakes when necessary.

Always check your surroundings while backing up.

- **When the vehicle is in a complex parking environment**

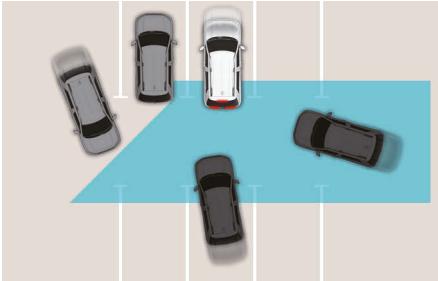

Rear Cross-Traffic Collision-Avoidance Assist may detect vehicles which are parking or pulling out near your vehicle (for example, a vehicle leaving beside your vehicle, a vehicle parking or pulling out in the rear area, a vehicle approaching your vehicle making a turn, etc.). If this occurs, the function may unnecessarily warn the driver and control the brake.

Always check your surroundings while backing up.

- **When the vehicle is parked diagonally**

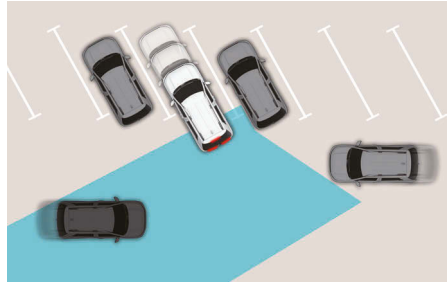

Rear Cross-Traffic Collision-Avoidance Assist may be limited when backing up diagonally, and may not detect the vehicle approaching from the left or right. If this occurs, the function may not warn the driver or control the brakes when necessary.

Always check your surroundings while backing up.

- When the vehicle is on or near a slope

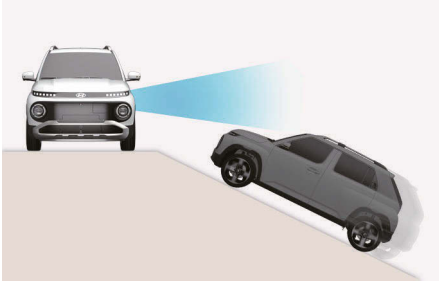

Rear Cross-Traffic Collision-Avoidance Assist may be limited when the vehicle is on an uphill or downhill slope, or near it, and may not detect the vehicle approaching from the left or right. If this occurs, the function may not warn the driver or control the brakes when necessary.

Always check your surroundings while backing up.

- Pulling into the parking space where there is a structure

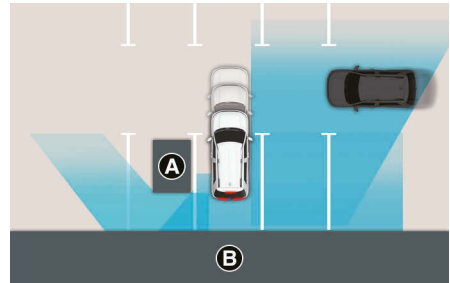

[A] Structure
[B] Wall

Rear Cross-Traffic Collision-Avoidance Assist may detect vehicles passing by in front of you when parking in reverse into a parking space with a wall or structure in the rear or side area. If this occurs, the function may unnecessarily warn the driver and control the brake.

Always check your surroundings while backing up.

- When the vehicle is parked rearward

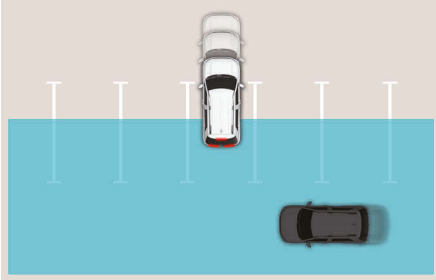

Rear Cross-Traffic Collision-Avoidance Assist may detect vehicles passing by behind you when parking in reverse into a parking space. If this occurs, the function may unnecessarily warn the driver and control the brake.

Always check your surroundings while backing up.

WARNING

- When you are towing a trailer or turn off Rear Cross-Traffic Collision-Avoidance Assist for safety reasons.
- Rear Cross-Traffic Collision-Avoidance Assist may not operate properly if interfered by strong electromagnetic waves.
- Rear Cross-Traffic Collision-Avoidance Assist may not operate for 3 seconds after the vehicle is started, or the rear corner radars are initialized.
- If the vehicle is turned off and restarted while the sensor is blocked or malfunctioned, the condition is maintained. Therefore, Rear Cross-Traffic Collision-Avoidance Assist is may not operate properly.

Reverse Parking Distance Warning (PDW)

 If equipped

Reverse Parking Distance Warning uses the rear ultrasonic sensors to detect and warns you if a person, animal, or object is within a certain distance when your vehicle is stopped or driving at low speed.

Detecting sensor

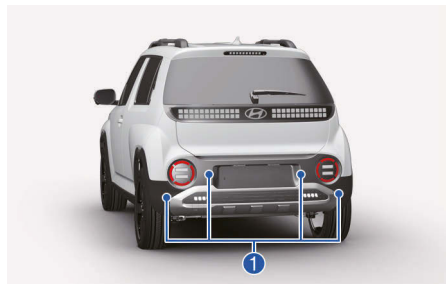

- (1) Rear ultrasonic sensors

Refer to the picture above for the detailed location of the detecting sensors.

Reverse Parking Distance Warning settings

WARNING

When the vehicle and the trailer is connected electrically, a warning message appears on the cluster, and Reverse Parking Distance Warning is deactivated. The function resumes after the trailer connector is disconnected. (if Hyundai genuine part equipped)

Warning methods

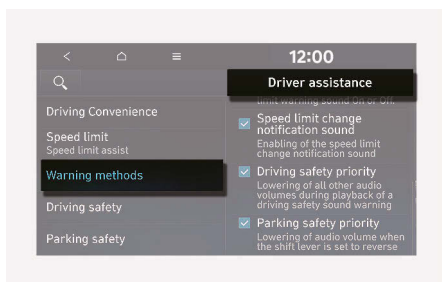
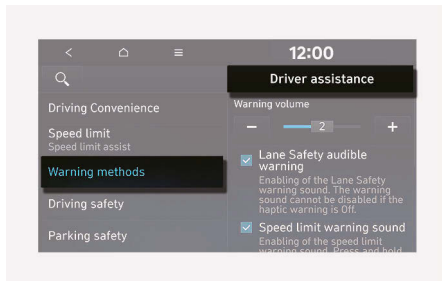

With the vehicle on, select **User Settings > Driver Assistance > Warning Methods > Warning Volume** on the instrument cluster or **Settings > Vehicle > Driver assistance > Warning methods** in the infotainment system to select following:

- **Warning volume:** The warning volume can be adjusted.

i Information

- If you change the Warning methods, the Warning methods of other Driver Assistance systems may change.
- Warning methods will maintain its last setting even if the vehicle is restarted.
- The setting menu may not be available for your vehicle depending on the vehicle features and specifications.

Auto PDW (Parking Distance Warning)

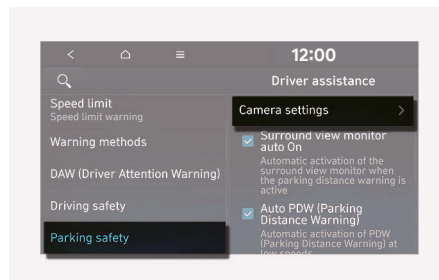

You can always turn on the Parking Distance Warning when driving slowly. With the vehicle on, select **User Settings > Driver Assistance > Parking Safety > Parking Distance Warning Auto On** on the instrument cluster or **Settings > Vehicle > Driver assistance > Parking safety > Auto PDW (Parking Distance Warning)** in the infotainment system.

i Information



When **Auto PDW (Parking Distance Warning)** is selected, the Parking Safety button indicator (PWA) stays on.

Reverse Parking Distance Warning operation

Reverse Parking Distance Warning

Reverse Parking Distance Warning operates under the following conditions.

- The gear is shifted to R (Reverse).

Distance from object	Warning indicator	Warning sound
	Cluster/Infotainment	
60-120cm (24-48 in.)		Buzzer beeps intermittently
30-60 cm (12-24 in.)		Buzzer beeps intermittently
within 30 cm (12 in.)		Beeps continuously

- The corresponding indicator illuminates whenever each ultrasonic sensor detects a person or object in its sensing range. Also an audible warning sounds.
- When more than two objects are detected at the same time, the closest one is warned with an audible warning.
- The shape of the indicator in the illustration may differ from the actual vehicle.

Reverse Parking Distance Warning malfunction and limitations

Parking Distance Warning malfunction

After starting the vehicle, a beep may sound when the gear is shifted to R (Reverse) to indicate Parking Distance Warning is operating properly.

However, if one or more of the following occurs, first check whether the ultrasonic sensor is damaged or blocked with foreign material. If it still does not work properly we recommend that your vehicle be inspected by an authorized HYUNDAI dealer.

- The audible warning does not sound.
- The buzzer sounds intermittently.
- The "**Check Parking Distance Warning system**" warning message appears on the cluster.

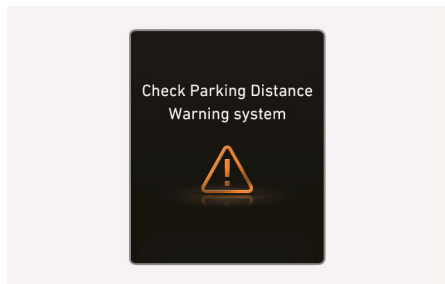

i Information

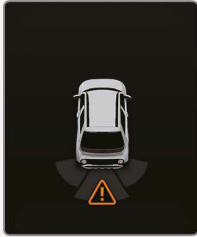

When the Parking Distance Warning is operating, if the function is not working normally or the ultrasonic sensor is blocked, the master (⚠) warning light appears in the direction of the corresponding sensor. You can check the warning in the Utility view on the instrument cluster.

Limitations of Reverse Parking Distance Warning

- Parking Distance Warning may not operate properly when:
 - Moisture is frozen to the sensor
 - Sensor is covered with substance, such as snow or water (Reverse Parking Distance Warning operates properly when such substance is removed.)
 - The weather is extremely hot or cold
 - The sensor or sensor assembly is disassembled
 - The surface of the sensor is pressed hard or hit with a hard object
 - The surface of the sensor is scratched with a sharp object
 - The sensors or its surrounding area is directly sprayed with high pressure washer
- Parking Distance Warning may malfunction when:
 - Heavy rain or water spray is present
 - Water flows on the surface of the sensor
 - Affected by another vehicle's sensors
 - The sensor is covered with snow or ice
 - Driving on uneven road, gravel roads or bushes
 - Objects that generates ultrasonic waves are near the sensor
 - License plate is installed in a different spot from the original location
 - The vehicle bumper height or ultrasonic sensor installation has been modified
 - Attaching equipment or accessories next to the ultrasonic sensors
 - Nearby presence of an ultrasonic wave source, for example, horn of another vehicle, engine sound of a motorcycle, air brake of a large vehicle
- The following objects may not be detected:
 - Sharp or slim objects, such as ropes, chains or small poles.
 - Narrow objects, such as corners of a square column
 - Objects, which tend to absorb sensor frequency, such as clothes, spongy material or snow.
 - Objects smaller than 100 cm (40 in.) in length and narrower than 14 cm (6 in.) in diameter.
 - Pedestrians, animals or objects that are very close to the ultrasonic sensors

WARNING

- Parking Distance Warning is a supplemental function. The operation of Parking Distance Warning can be affected by several factors (including environmental conditions). It is the responsibility of the driver to always check the rear views before and while parking.
- Your new vehicle warranty does not cover any accidents or damage to the vehicle due to the malfunction of Parking Distance Warning.
- Pay close attention when driving near objects, pedestrians, and especially children. Some objects may not be detected by the ultrasonic sensors, due to the objects distance, size or material, all of which can limit the effectiveness of the sensor.
- Parking Distance Warning does not warn you in the order of detection. It varies depending on the speed of the vehicle or the shape of a person, animal, or object.
- If the Parking Distance Warning does not operate properly, we recommend that your vehicle be inspected by an authorized HYUNDAI dealer.

Forward/Reverse Parking Distance Warning (PDW)

+ If equipped

Forward/Reverse Parking Distance Warning uses the front and rear ultrasonic sensors to detect and warns you if a person, animal, or object is within a certain distance when your vehicle is stopped or driving at low speed.

Detecting sensor

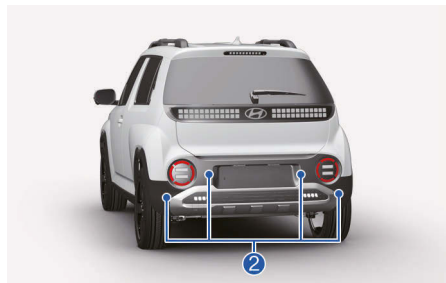

(1) Front ultrasonic sensors

(2) Rear ultrasonic sensors

Refer to the picture above for the detailed location of the detecting sensors.

Forward/Reverse Parking Distance Warning settings

WARNING

When the vehicle and the trailer is connected electrically, a warning message appears on the cluster, and Reverse Parking Distance Warning is deactivated. The function resumes after the trailer connector is disconnected. (if Hyundai genuine part equipped)

Warning methods

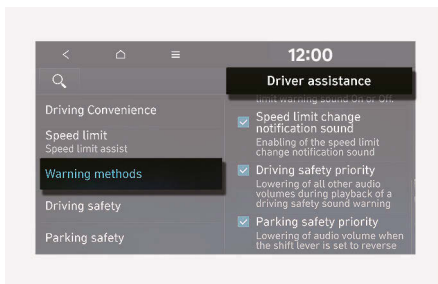
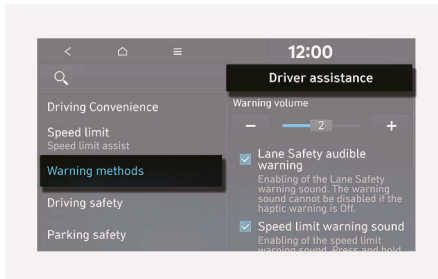

With the vehicle on, select **User Settings** > **Driver Assistance** > **Warning Methods** > **Warning Volume** on the instrument cluster or **Settings** > **Vehicle** > **Driver assistance** > **Warning methods** in the infotainment system to select following:

- **Warning volume:** The warning volume can be adjusted.

Information

- If you change the Warning methods, the Warning methods of other Driver Assistance systems may change.
- Warning methods will maintain its last setting even if the vehicle is restarted.
- The setting menu may not be available for your vehicle depending on the vehicle features and specifications.

Auto PDW (Parking Distance Warning)

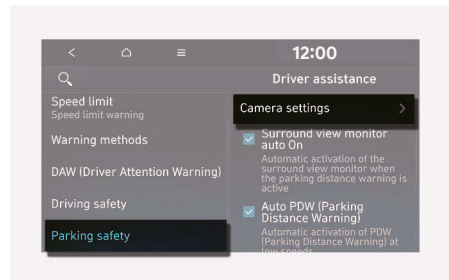

You can always turn on the Parking Distance Warning when driving slowly. With the vehicle on, select **User Settings** > **Driver Assistance** > **Parking Safety** > **Parking Distance Warning Auto On** on the instrument cluster or **Settings** > **Vehicle** > **Driver Assistance** > **Parking Safety** > **Auto PDW (Parking Distance Warning)** in the infotainment system.

Information

When **Auto PDW (Parking Distance Warning)** is selected, the Parking Safety button indicator () stays on.

Forward/Reverse Parking Distance Warning operation

Parking Safety button



Press the Parking Safety (P) button to turn on Forward/Reverse Parking Distance Warning. Press the button again to turn off the function.

- When the gear is shifted to R (Reverse), Parking Distance Warning automatically turns on (Parking Safety button indicator on).
- When the gear is shifted to R (Reverse), the Parking Safety remains active for safe driving. (for Europe)



Forward Parking Distance Warning

Forward Parking Distance Warning operates when one of the condition is satisfied.

- The gear is shifted from R (Reverse) to D (Drive) with Reverse Parking Distance Warning on.
- The gear is in D (Drive) and the Parking Safety button indicator light is on.
- Shift to D (Drive) when the function is off (Only when **Vehicle > Driver Assistance > Parking safety > Auto PDW (Parking Distance Warning)** is selected in the infotainment system.)

i Information

- Forward Parking Distance Warning operates only when the vehicle's forward speed is below 10 km/h (6 mph).
- While the gear is in R (Reverse), Forward Parking Distance Warning warns only the front outer side area. (within 60 cm (24 in.))
- Forward Parking Distance Warning is deactivated if the vehicle speed reaches above 30 km/h (18 mph). It may not reactivate although the vehicle speed drops below 10 km/h (6 mph).



Distance from object	Warning indicator	Warning sound
	Cluster/Infotainment	
60-120 cm (24-48 in.)		Buzzer beeps intermittently (front inner side)
30-60 cm (12-24 in.)		Beeps more frequently
within 30 cm (12 in.)		Beeps continuously

- The corresponding indicator illuminates whenever each ultrasonic sensor detects a person or object in its sensing range. Also an audible warning sounds.
- When more than two objects are detected at the same time, the closest one is warned with an audible warning.
- The shape of the indicator in the illustration may differ from the actual vehicle.

Reverse Parking Distance Warning

Reverse Parking Distance Warning operates under the following conditions.

- The gear is shifted to R (Reverse).

Distance from object	Warning indicator	Warning sound
	Cluster/Infotainment	
60-120 cm (24-48 in.)		Buzzer beeps intermittently
30-60 cm (12-24 in.)		Buzzer beeps intermittently
within 30 cm (12 in.)		Beeps continuously

- The corresponding indicator illuminates whenever each ultrasonic sensor detects a person or object in its sensing range. Also an audible warning sounds.
- When more than two objects are detected at the same time, the closest one is warned with an audible warning.
- The shape of the indicator in the illustration may differ from the actual vehicle.

Forward/Reverse Parking Distance Warning malfunction and limitations

Parking Distance Warning malfunction

After starting the vehicle, a beep may sound when the gear is shifted to R (Reverse) to indicate Parking Distance Warning is operating properly.

However, if one or more of the following occurs, first check whether the ultrasonic sensor is damaged or blocked with foreign material, If it still does not work properly we recommend that your vehicle be inspected by an authorized HYUNDAI dealer.

- The audible warning does not sound.
- The buzzer sounds intermittently.
- The "**Check Parking Distance Warning system**" warning message appears on the cluster.

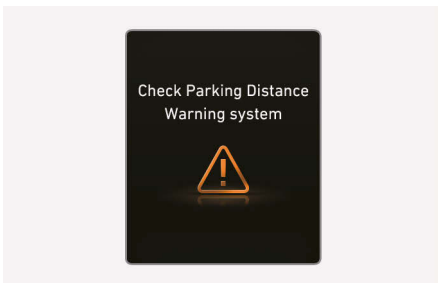

i Information

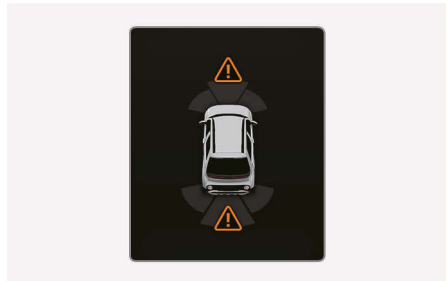

When the Parking Distance Warning is operating, if the function is not working normally or the ultrasonic sensor is blocked, the master (⚠) warning light appears in the direction of the corresponding sensor. You can check the warning in the Utility view on the instrument cluster.

Limitations of Forward/Reverse Parking Distance Warning

- Parking Distance Warning may not operate properly when:
 - Moisture is frozen to the sensor
 - Sensor is covered with substance, such as snow or water (Forward/Reverse Parking Distance Warning operates properly when such substance is removed.)
 - The weather is extremely hot or cold
 - The sensor or sensor assembly is disassembled
 - The surface of the sensor is pressed hard or hit with a hard object
 - The surface of the sensor is scratched with a sharp object
 - The sensors or its surrounding area is directly sprayed with high pressure washer

- Parking Distance Warning may malfunction when:
 - Heavy rain or water spray is present
 - Water flows on the surface of the sensor
 - Affected by another vehicle's sensors
 - The sensor is covered with snow or ice
 - Driving on uneven road, gravel roads or bushes
 - Objects that generates ultrasonic waves are near the sensor
 - License plate is installed in a different spot from the original location
 - The vehicle bumper height or ultrasonic sensor installation has been modified
 - Attaching equipment or accessories next to the ultrasonic sensors
 - Nearby presence of an ultrasonic wave source, for example, horn of another vehicle, engine sound of a motorcycle, air brake of a large vehicle
- The following objects may not be detected:
 - Sharp or slim objects, such as ropes, chains or small poles.
 - Narrow objects, such as corners of a square column
 - Objects, which tend to absorb sensor frequency, such as clothes, spongy material or snow.
 - Objects smaller than 100 cm (40 in.) in length and narrower than 14 cm (6 in.) in diameter.
 - Pedestrians, animals or objects that are very close to the ultrasonic sensors

WARNING

- Parking Distance Warning is a supplemental function. The operation of Parking Distance Warning can be affected by several factors (including environmental conditions). It is the responsibility of the driver to always check the front and rear views before and while parking.
- Your new vehicle warranty does not cover any accidents or damage to the vehicle due to the malfunction of Parking Distance Warning.
- Pay close attention when driving near objects, pedestrians, and especially children. Some objects may not be detected by the ultrasonic sensors, due to the objects distance, size or material, all of which can limit the effectiveness of the sensor.
- Parking Distance Warning does not warn you in the order of detection. It varies depending on the speed of the vehicle or the shape of a person, animal, or object.
- If the Parking Distance Warning does not operate properly, we recommend that your vehicle be inspected by an authorized HYUNDAI dealer.

Reverse Parking Collision-Avoidance Assist (PCA)

 If equipped

Reverse Parking Collision-Avoidance Assist detects pedestrians or objects behind the vehicle and may warn you or assist you with braking to help avoid a collision while your vehicle is reversing.

Detecting sensor

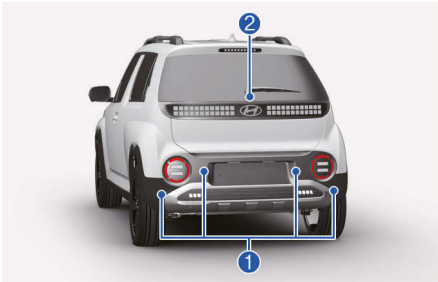

- (1) Rear ultrasonic sensors
- (2) Wide-rear view camera

Refer to the picture above for the detailed location of the detecting sensors.

Reverse Parking Collision-Avoidance Assist settings

WARNING

When the vehicle and the trailer is connected electrically, a warning message appears on the cluster, and Reverse Parking Collision-Avoidance Assist is deactivated. The function resumes after the trailer connector is disconnected. (if Hyundai genuine part equipped)

Warning methods

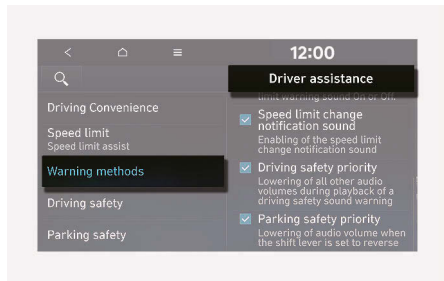
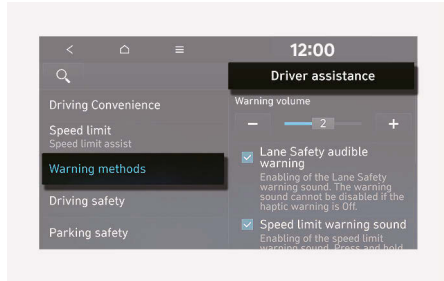

With the vehicle on, select **User Settings > Driver Assistance > Warning Methods > Warning Volume** on the instrument cluster or **Settings > Vehicle > Driver assistance > Warning methods** in the infotainment system to select following:

- **Warning volume:** The warning volume can be adjusted.

i Information

- If you change the Warning methods, the Warning methods of other Driver Assistance systems may change.
- Warning methods will maintain its last setting even if the vehicle is restarted.
- The setting menu may not be available for your vehicle depending on the vehicle features and specifications.

Parking Safety

With the vehicle on, select or deselect **Vehicle > Driver assistance > Parking safety** in the infotainment system to set whether to use each function.

i Information

When the vehicle is turned on, the rear safety selection is set as the default, and the rear safety setting is maintained even if the vehicle is turned off and then restarted.

Reverse Parking Collision-Avoidance Assist operation

Turning Parking Collision Avoidance Assist On/Off



Press and hold the Parking Safety (P \blacktriangle) button more than 2 seconds, to turn the Parking Collision-Avoidance Assist on or off.

Operating conditions

If Reverse Parking Collision-Avoidance Assist detects a risk of collision behind the vehicle with a pedestrian or an object, Reverse Parking Collision-Avoidance Assist warns the driver with an audible warning and warning message on the cluster. If Surround View Monitor is operating, a warning appears on the infotainment screen.

If collision is imminent, Reverse Parking Collision-Avoidance Assist assists you with braking.

Select "**Backward Safety**" from the "**Parking safety**" menu of the infotainment system. Parking Collision-Avoidance Assist is enabled when the following conditions are satisfied:

- The tailgate and door are closed
- The parking brake is released
- A trailer is not connected
- The gear is shifted to R (Reverse)
- Vehicle speed is below 10 km/h (6 mph) (detecting pedestrians)
- Vehicle speed is below 4 km/h (2 mph) (detecting objects)
- Parking Collision-Avoidance Assist components such as the rear view camera and the rear ultrasonic sensors are in normal conditions

When Reverse Parking Collision-Avoidance Assist activates, a line appears behind the vehicle image in the instrument cluster.

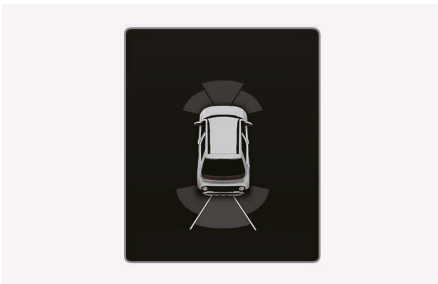

i Information

Reverse Parking Collision-Avoidance Assist operates only once after shifting the gear to R (Reverse). To reactivate Parking Collision-Avoidance Assist, shift the gear from another gear to R (Reverse).

Off conditions

If collision is imminent, Reverse Parking Collision-Avoidance Assist assists you with braking. Braking assist is released after 5 minutes. Immediately depress the brake pedal and check vehicle surroundings. Braking assist is also released in the following conditions when:

- The gear is shifted to P (Park) or D (Drive)
- The brake pedal is depressed with sufficient power

i Information

When Parking Collision-Avoidance Assist is activated while reversing, braking control will be released after 5 minutes and the parking brake will be engaged.

Reverse Parking Collision-Avoidance Assist malfunction and limitations

Reverse Parking Collision-Avoidance Assist malfunction

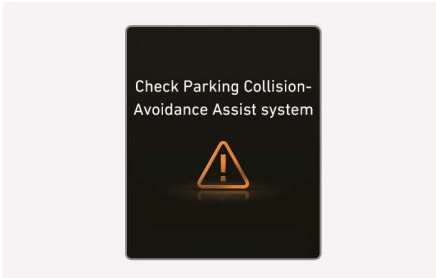

When Reverse Parking Collision-Avoidance Assist or other related functions are not working properly, the "**Check Parking Collision-Avoidance Assist system**" warning message appears on the instrument cluster, and Reverse Parking Collision-Avoidance Assist turns off automatically. We recommend that your vehicle be inspected by an authorized HYUNDAI dealer.

Reverse Parking Collision-Avoidance Assist disabled

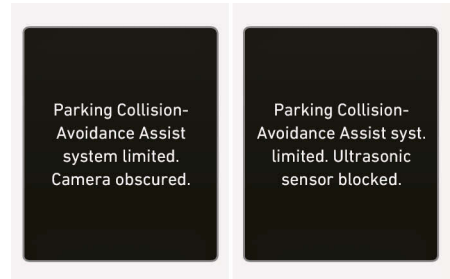

The "**Parking Collision-Avoidance Assist system limited. Camera obscured.**" or "**Parking Collision-Avoidance Assist syst. limited. Ultrasonic sensor blocked.**" warning message appears on the cluster if the following situations occur:

- The rear view camera or rear ultrasonic sensor(s) is covered with foreign material, such as snow or rain, etc.
- There is inclement weather, such as heavy snow, heavy rain, etc.

If this occurs, Reverse Parking Collision-Avoidance Assist may turn off or may not operate properly. Check whether the rear view camera and rear ultrasonic sensors are clean.

Limitations of Reverse Parking Collision-Avoidance Assist

Reverse Parking Collision-Avoidance Assist may not assist braking or warn the driver even if there are pedestrians or objects under the following circumstances:

- Problems with vehicle
 - Any non-factory equipment or accessory is installed
 - Your vehicle is unstable due to an accident or other causes
 - Bumper height or rear ultrasonic sensor installation has been modified
 - Wide-rear view camera(s) or ultrasonic sensor(s) is damaged
 - Wide-rear view camera(s) or the ultrasonic sensor(s) is stained with foreign material, such as snow, dirt, etc.
 - Wide-rear view camera(s) is obscured by a light source or by inclement weather, such as heavy rain, fog, snow, etc.
 - When brake parts, such as brake discs, calipers, etc. are modified
 - When wheel alignment is improper, and parts are modified
 - When accessories are attached to the steering wheel or steering parts are modified.
- Problems with the surroundings
 - The surrounding is very bright or very dark
 - Outside temperature is very high or very low
 - The wind is either strong (above 20 km/h (12 mph)) or blowing perpendicular to the rear bumper
 - Objects generating excessive noise, such as vehicle horns, loud motorcycle vehicles or truck air brakes, are near your vehicle
 - An ultrasonic sensor with similar frequency is near your vehicle
 - The road is slippery or inclined
 - The image of the pedestrian in the front view camera is indistinguishable from the background
 - Any objects, such as the sound of vehicle horn or engine of a motorcycle, and air brake of a large vehicle that generate ultrasonic waves are near the sensor
 - When objects that generate ultrasonic waves are near the sensor
 - Wireless device with transmission operates near the ultrasonic sensor
 - When affected by parking distance warning of another vehicle

- Problems with pedestrian or object
 - The pedestrians are difficult to detect
 - There is ground height difference between the vehicle and the pedestrian
 - The pedestrian is near the rear edge of the vehicle
 - The pedestrian is not standing upright
 - The pedestrian is either very short or very tall to detect
 - The pedestrian or cyclist is wearing clothing that easily blends into the background, making it difficult to detect
 - The pedestrian is wearing clothing that does not reflect ultrasonic waves well
 - Size, thickness, height, or shape of the object does not reflect ultrasonic waves well (for example, low object, narrow object, circular pillar, small pillar, corners of a square pillar, bush, curbs, carts, edge of a wall, etc.)
 - The pedestrian or the object is moving
 - The pedestrian or the object is very close to the rear of the vehicle
 - There is a large object such as a wall is behind the pedestrian or the object
 - The object is not located at the front or rear center of your vehicle
 - The object is not parallel to the rear bumper
 - The sensors cannot detect the pedestrians and objects
- Problems with driving condition
 - The driver drives the vehicle immediately after shifting to R (Reverse) or D (Drive)
 - The driver accelerates or circles the vehicle
 - The vehicle is driven immediately after starting the vehicle

WARNING

Take the following precautions when using Reverse Parking Collision-Avoidance Assist:

- Always exercise extreme caution while driving. The driver is responsible for braking and safe driving.
- Always pay attention to road and traffic conditions while driving, whether or not there is a warning.
- Always look around your vehicle to make sure there are no pedestrians or objects before moving the vehicle.
- The performance of Reverse Parking Collision-Avoidance Assist may vary under certain conditions. If vehicle speed is above 4 km/h (2 mph), Reverse Parking Collision-Avoidance Assist will provide collision avoidance assist only when pedestrians are detected. Always look around and pay attention when driving your vehicle.
- Reverse Parking Collision-Avoidance Assist may operate differently under certain conditions. If the vehicle moves forward and backward repeatedly, Reverse Parking Collision-Avoidance Assist may fail to assist braking or to warn the driver. Always pay attention when driving your vehicle.

- Some objects may not be detected by the rear ultrasonic sensors due to the objects distance, size or material, all of which can limit the effectiveness of the sensor.
 - Reverse Parking Collision-Avoidance Assist may not operate properly or may operate unnecessarily depending on the road conditions and the surroundings.
 - Do not solely rely on Parking Collision-Avoidance Assist. Doing so may lead to vehicle damage or injuries.
-

CAUTION

- Noise may be heard when sudden braking occurs to avoid a collision.
- If any other warning sound such as the seat belt warning chime is already generated, Parking Collision-Avoidance Assist warning may not sound.
- Parking Collision-Avoidance Assist may not work properly if the bumper has been damaged, replaced or repaired.
- Parking Collision-Avoidance Assist may not operate properly if interfered by strong electromagnetic waves.
- Playing the vehicle audio system at high volume may prevent passengers from hearing Parking Collision-Avoidance Assist warning sounds.
- Turn off Parking Collision-Avoidance Assist when towing a trailer. If towing and moving in reverse, Parking Collision-Avoidance Assist will activate as it detects the trailer.

- The brake control may not operate properly depending on the status of ESC (Electronic Stability Control).
There will only be a warning when:
 - The ESC (Electronic Stability Control) warning light is on
 - ESC (Electronic Stability Control) is engaged in a different function
-

CAUTION

Take the following precautions to maintain optimal performance of the detecting sensors:

- Always keep the wide-rear view cameras and ultrasonic sensors clean.
- Do not use any cleanser containing acid or alkaline detergents when cleaning the camera lens. Use only a mild soap or neutral detergent, and rinse thoroughly with water.
- Do not spray the wide-rear view cameras or the rear ultrasonic sensors or their surrounding area directly with a high pressure washer. It may cause the wide angle cameras or the ultrasonic sensors to malfunction.
- Do not apply objects, such as a bumper sticker or a bumper guard, near the wide angle cameras or ultrasonic sensors or apply paint to the bumper. Doing so may adversely affect the performance of Parking Collision-Avoidance Assist.
- Never disassemble or apply impact on the wide angle cameras or the ultrasonic sensors components.

- Do not apply unnecessary force on the wide-rear view cameras or the ultrasonic sensors. Reverse Parking Collision-Avoidance Assist may not operate properly if the wide angle cameras or the ultrasonic sensor(s) is forcibly moved out of proper alignment. We recommend that your vehicle be inspected by an authorized HYUNDAI dealer.

i Information

Reverse Parking Collision-Avoidance Assist can detect a pedestrian or an object when:

- A pedestrian is standing behind the vehicle
- A large obstacle, such as a vehicle, is parked in the rear center of your vehicle

Declaration of conformity

Front radar

+ if equipped

The radio frequency components complies:

- For Europe and other Europe territories



Model : MRR-35

Hereby MRR-35 has been so constructed that it can be operated in at least one Member State without infringing applicable requirements of use of radio spectrum. (RED article 10.2)

Hereby, HL Klemove Corp declares that the radio equipment type MRR-35 is in compliance with Directive 2014/53/EU.



The full text of the EU declaration of conformity is available at the following as next page. (Case 1 : Include DoC in manual)

Case 2 : <https://hklmove.com/solutions.html>

- For Oman

OMAN-TRA
TRA/TA-R/14933/22
D202960

- For United Arab Emirates

 <p>هيئة تنظيم الاتصالات والذكورة الإلكترونية والخدمات السحابية والخدمات الإلكترونية</p>	<p>TDRA - UNITED ARAB Emirates Male Dealer ID Name: SM GLOBAL LLC TAIRITE: ER16046/22 Model Name: MRR-35 Product Type: Vehicle Radar</p>	
---	--	--

- For Jordan

TRC/31/11066/2022

- For Uzbekistan



- For Israel

Ministry of Communication permit number : 51-89758

א. השימוש במכשיר פסור מרשיין הפעלה אלחוטי
לא מוגן מהפרעות וללא הפרעה למערכות אחרות הפועלות בדיון.
ב. ר"ק "בפעלת בוק" לשימוש עצמי של הלקוח בלבד, היגוד פסור מרשיין הפעלה אלחוטי.
מתן "שרות בוק" לצד ג' מחייב רשיין מיוחד ממשדר הקשורות.
ג. אסור להחליף את האנטנה המקורית של המכשיר, ולא לעשות בו כל שינוי טכני אחר.

- For Thailand



- For Taiwan

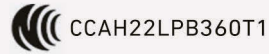

電信法第 48 條。低功率電波輻射性電機管理辦法
第十二條

經型式認證合格之低功率射頻電機，非經許可，公司、商號或使用者均不得擅自變更頻率、加大功率或變更原設計之特性及功能。
第十四條

低功率射頻電機之使用不得影響飛航安全及干擾合法通信；經發現有干擾現象時，應立即停用，並改善至無干擾時方得繼續使用。前項合法通信，指依電信法規定作業之無線電通信。低功率射頻電機須忍受合法通信或工業、科學及醫療用電波輻射性電機設備之干擾。

Article 12

Without permission, any company, firm or user shall not alter the frequency, increase the power, or change the characteristics and functions of the original design of the certified lower power frequency electric machinery.

Article 14

The application of low power frequency electric machineries shall not affect the navigation safety nor interface a legal communication, if an interference is found, the service will be suspended until improvement is made and the interference no longer exist.

- For Paraguay



NR : 2023-01-I-0006

- For Singapore

Complies with
IMDA Standards
[N6117-22]

- For Philippines



NTC

Type Approved
No. ESD-RCE-2332110

- For Mexico

IFT : BLHLMR23-07397

- For Brazil



02588-23-09644

- For Indonesia



87313/SDPPI/2023
13085



Peringatan: Melaksanakan prosedur dalam cara pemakaian yang benar
untuk menghindari terjadinya kecelakaan yang dapat mengakibatkan
kerusakan terhadap peralatan elektronik.

- For Republic of South Africa



TA-2022/3018

APPROVED

Rear corner radar

+ if equipped

The radio frequency components complies:

- For Europe and CE certified countries

Declaration of Conformity
Radiocontrolled Vehicle components



Hereby, APTIV, 42367 Wuppertal declares that this 2H5TR is in compliance with the essential requirements and other relevant provisions of Directive 2014/53/EU (RED).
The original declaration of conformity can be accessed at the following link : www.aptiv.com/automotive-homologation

frequency band 76-77 GHz
Maximum Output Power 30 dBm (1,0 W)

- For Ghana

NCA approved: 7E6-M1-X63-SRD

- For Singapore



- For Oman

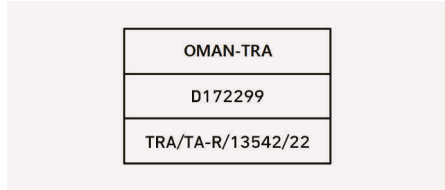

- For United Arab Emirates



- For Republic of South Africa



- For Morocco



- For Senegal



- For Zambia



- For Jordan



- For Paraguay



- For Serbia



• For Nigeria

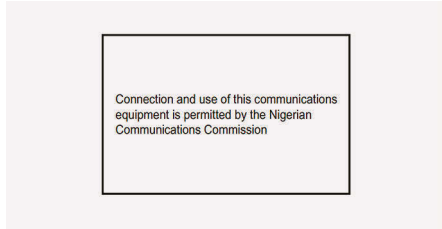

• For Malaysia



• For Pakistan



• For Israel

14 הנגיס הוחרים והפחות המסודר:
 לפני השימוש יודאג היבואן של אריות הוצגות של המוצר יודבק מדבקה, זה יזיה השום כי:
 א. השימוש במכשיר יהיה על בסיס יעשתיי פטור מרשיון הפעלה אלוטיו.
 ב. לא מוגן מהפרעות וללא הפרעה למערכות אחרות הפועלת כיון.
 ג. רק "בעמלת בוק" לשימוש נעמי של הלקוח בלבד, היוד מוקר מרשיון הפעלה אלוטיו.
 ד. מות "שרות בוק" לבד ג מחייב רשיון מיוחד ממסדר התקשורת.
 ג. אסור להחליף את ההגנות המקורית של המכשיר, ולא לעשות בו כל שינוי טכני אחר.
 חוק מספר: 63-66570

א. השימוש במכשיר יהיה על בסיס "מסני" ופטור מרשיון הפעלה אלוטיו.
 ב. לא מוגן מהפרעות וללא הפרעה למערכות אחרות הפועלות כיון.
 ג. רק "בעמלת בוק" לשימוש נעמי של הלקוח בלבד, היוד מוקר מרשיון הפעלה אלוטיו.
 ד. מות "שרות בוק" לבד ג מחייב רשיון מיוחד ממסדר התקשורת.
 ג. אסור להחליף את ההגנות המקורית של המכשיר, ולא לעשות בו כל שינוי טכני אחר.
 ה. המפעל בתחום תדרים של "output power of the device" על עבר ציד אלוטיו, "operating frequencies of the device".
 הספק השידור שלו אינו עולה על "output power of the device"

• For Mexico

IFETEL: RCPAP2H22-1601

"La operación de este equipo está sujeta a las siguientes dos condiciones:
 (1) es posible que este equipo o dispositivo no cause interferencia perjudicial y (2) este equipo o dispositivo debe aceptar cualquier interferencia, incluyendo la que pueda causar su operación no deseada."

• For Indonesia

83300/SDPPI/2022
 10976

• For Taiwan



電信法第 48 條, 低功率電波輻射性電機管理辦法
第十二條

經型式認證合格之低功率射頻電機, 非經許可, 公司、商號或使用者均不得擅自變更頻率、加大功率或變更原設計之特性及功能。
第十四條

低功率射頻電機之使用不得影響飛航安全及干擾合法通信; 經發現有干擾現象時, 應立即停用, 並改善至無干擾時方得繼續使用。前項合法通信, 指依電信法規定作業之無線電通信。低功率射頻電機須忍受合法通信或工業、科學及醫療用電波輻射性電機設備之干擾。

Article 12

Without permission, any company, firm or user shall not alter the frequency, increase the power, or change the characteristics and functions of the original design of the certified lower power frequency electric machinery.

Article 14

The application of low power frequency electric machineries shall not affect the navigation safety nor interface a legal communication, if an interference is found, the service will be suspended until improvement is made and the interference no longer exist.

• For Brazil



04905-22-10187

Este equipamento opera em caráter secundário, isto é, não tem direito à proteção contra interferência prejudicial, mesmo de estações do mesmo tipo, e não pode causar interferência a sistemas operando em caráter primário.

• For Philippines



NTC

Type Approved
No. ESD-RCE-2229725

• For Thailand



- 1) เครื่องโทรคมนาคมและอุปกรณ์นี้ มีความสอดคล้องตามมาตรฐานเรดิโอภาคพื้นของ กสทช.
- 2) เครื่องโทรคมนาคมนี้มีระดับการแผ่คลื่นแม่เหล็กไฟฟ้าสอดคล้องตามมาตรฐานความปลอดภัยต่อสุขภาพของมนุษย์จากการใช้เครื่องโทรคมนาคมทั้งหมดและการจัดการโทรคมนาคมแห่งชาติประกาศกสทช.

• For Ukraine



UA RF: 1APT V 2HTR

справжнім (найменування виробника) заявляє, що тип радіобладнання (позначення типу радіобладнання) відповідає Технічному регламенту радіобладнання;

повний текст декларації про відповідність доступний на веб-сайті за такою адресою:
www.aptiv.com/automotive-homologation

8. Emergency situations

Hazard warning flasher	8-2
In case of an emergency while driving	8-2
If the vehicle stalls while driving.....	8-2
If the vehicle stalls at a crossroad or crossing	8-2
If you have a flat tire while driving.....	8-3
If the vehicle does not start	8-3
Confirm the EV battery is not low on the charge gauge.....	8-3
Jump starting (12 V battery).....	8-3
Tire pressure monitoring system (TPMS).....	8-7
Resetting TPMS.....	8-7
Low tire pressure light	8-8
TPMS malfunction indicator.....	8-10
If you have a flat tire (with Tire Mobility Kit).....	8-10
Introduction.....	8-11
Notes on the safe use of the Tire Mobility Kit.....	8-11
Components of the Tire Mobility Kit	8-13
Using the Tire Mobility Kit when a tire is flat	8-14
How to adjust tire pressure	8-16
Towing.....	8-17
Towing service	8-17
Removable towing hook.....	8-18
Emergency commodity.....	8-19
Fire extinguisher	8-19
First aid kit	8-19
Triangle reflector.....	8-19
Tire pressure gauge	8-19
Pan-European eCall System (FOR EUROPE)	8-21
Information on data processing (For Europe).....	8-24
Pan-European eCall System (For Europe).....	8-26
UAE eCall System (For UAE)	8-30
Information on data processing (For UAE).....	8-33
UAE eCall System (For UAE).....	8-35
eCall certification label.....	8-38

Hazard warning flasher

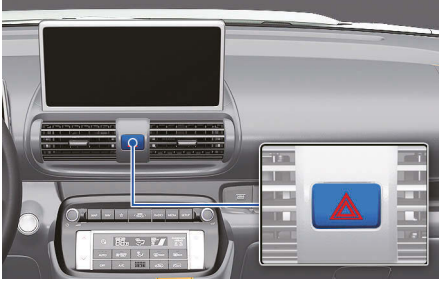

The hazard warning flasher serves as a warning to other drivers to exercise extreme caution when approaching, overtaking, or passing your vehicle.

It should be used whenever emergency repairs are being made or when the vehicle is stopped near the edge of a roadway.

To turn the hazard warning flasher on or off, press the hazard warning flasher button with the Start/Stop button in any position. The hazard warning flasher button is located in the center fascia panel. All turn signal lights will flash simultaneously.

- The hazard warning flasher operates regardless of whether your vehicle is ON (READY indicator ON) or not.
- The turn signals do not work when the hazard flasher is on.

In case of an emergency while driving

If the vehicle stalls while driving

- Reduce your speed gradually, keeping a straight line. Move cautiously off the road to a safe place.
- Turn on your hazard warning flasher.
- Try to start the vehicle again. If your vehicle will not start, we recommend that you contact an authorized HYUNDAI dealer or seek other qualified assistance.

If the vehicle stalls at a crossroad or crossing

If the vehicle stalls at a crossroads or crossing, if safe to do so, shift the gear to N (Neutral) and then push the vehicle to a safe location.

To stay N (Neutral) while the vehicle is off, refer to the "To stay in N (Neutral) when vehicle is OFF" section in chapter 6.

If you have a flat tire while driving

If a tire goes flat while you are driving:

- Take your foot off the accelerator pedal and let the vehicle slow down while driving straight ahead. Do not apply the brakes immediately or attempt to pull off the road as this may cause loss of vehicle control resulting in an accident. When the vehicle has slowed to such a speed that it is safe to do so, brake carefully and pull off the road. Drive off the road as far as possible and park on firm, level ground. If you are on a divided highway, do not park in the median area between the two traffic lanes.
- When the vehicle is stopped, press the hazard warning flasher button, shift the gear to P (Park), apply the parking brake, and press the Start/Stop button to the OFF position.
- Have all passengers get out of the vehicle. Be sure they all get out on the side of the vehicle that is away from traffic.
- When changing a flat tire, follow the instructions provided later in this chapter.

If the vehicle does not start

Confirm the EV battery is not low on the charge gauge

- Be sure the gear is in P (Park). The vehicle starts only when the gear is in P (Park).
- Check the 12 V battery connections to be sure they are clean and tight.
- Turn on the interior light. If the light dims or goes out when you operate the starter, the 12 V battery is drained.

Do not push or pull the vehicle to start it. This could cause damage to your vehicle.

Jump starting (12 V battery)

Jump starting can be dangerous if done incorrectly. Follow the jump starting procedure in this section to avoid serious injury or damage to your vehicle. If in doubt about how to properly jump start your vehicle, we strongly recommend that you have a service technician or towing service do it for you.

WARNING

To prevent **SERIOUS INJURY** or **DEATH** to you or bystanders, always follow these precautions when working near or handling the battery:

Always read and follow instructions carefully when handling a battery.



Wear eye protection designed to protect the eyes from acid splashes.



Keep all flames, sparks, or smoking materials away from the battery.



Hydrogen is always present in battery cells, is highly combustible, and may explode if ignited.



Keep batteries out of reach of children.



Batteries contain sulfuric acid which is highly corrosive. Do not allow acid to contact your eyes, skin or clothing.

If acid gets into your eyes, flush your eyes with clean water for at least 15 minutes and get immediate medical attention. If acid gets on your skin, thoroughly wash the area. If you feel pain or a burning sensation, get medical attention immediately.



- When lifting a plastic-cased battery, excessive pressure on the case may cause battery acid to leak. Lift with a battery carrier or with your hands on opposite corners.
- Do not attempt to jump start your vehicle if your battery is frozen.
- NEVER attempt to recharge the battery when the vehicle's battery cables are connected to the battery.
- The electrical ignition system works with high voltage.
NEVER touch these components with the vehicle running or when the Start/Stop button is in the ON position.
- The electrical ignition system works with high voltage. NEVER touch these components with the READY indicator ON or when the Start/Stop button is in the ON position.
- Do not allow the (+) and (-) jumper cables to touch. It may cause sparks.
- The battery may rupture or explode when you jump start with a low or frozen battery.
- Do not directly connect the (-) to the jump cable. Connect the (-) to the one of the metallic parts located far from the jump cable in the vehicle. The direct (-) connection to the jump cable may cause an explosion.

- Be sure to use only 12 V battery to jump start. Using batteries with other voltages to jump start can damage the battery or even provoke an explosion.

Jump starting procedure

i Information

When you jump start your vehicle, use the jumper terminal in the motor compartment.

1. Position the vehicles close enough that the jumper cables reach, but do not allow the vehicle body parts to contact.
2. Avoid fans or any moving parts in the motor compartment at all times, even when the vehicles are turned off.
3. Turn off all electrical devices such as radios, lights, air conditioning, etc. Put the vehicles in P (Park) and set the parking brake. Turn both vehicles OFF.
4. Open the hood.
5. Remove the motor compartment fuse box cover.

! CAUTION

Before jump starting, make sure to correctly identify the positive (+) and negative (-) terminals to avoid reverse polarity connections.

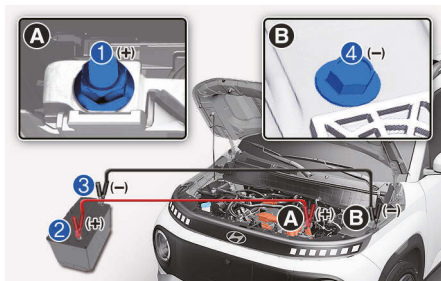

6. Connect the jumper cables in the exact sequence shown in the illustration. First connect one jumper cable to the red, positive (+) jumper terminal of your vehicle (1).
7. Connect the other end of the jumper cable to the red, positive (+) battery/jumper terminal of the assisting vehicle (2).
8. Connect the second jumper cable to the black, negative (-) battery/jumper terminal of the assisting vehicle (3).
9. Connect the other end of the second jumper cable to the black, negative (-) chassis ground of your vehicle (4).

Do not allow the jumper cables to contact anything except the correct battery or jumper terminals or the correct ground. Do not lean over the battery when making connections.

! WARNING

Do not connect the jumper cable to the negative (-) jumper terminal of the discharged battery. A spark could cause the battery to explode and lead to a personal injury or vehicle damage.

10. Start the assisting vehicle and let it run at about for a few minutes. Then start your vehicle.
11. Keep your vehicle operating for at least 30 minutes at idle or driving to assure your battery receives enough charge to be able to start on its own after the vehicle is shut off. A complete dead battery may require as long as 60 minutes runtime to fully recharge it. If vehicle is run for less, the battery may not restart.

If your vehicle does not start after a few attempts, it probably requires servicing. In this event please seek qualified assistance. If the cause of your battery discharging is not apparent, we recommend that your vehicle be inspected by an authorized HYUNDAI dealer.

Disconnect the jumper cables in the exact reverse order you connected them:

1. Disconnect the jumper cable from the black, negative (-) chassis ground of your vehicle (4).
2. Disconnect the other end of the jumper cable from the black, negative (-) battery/chassis ground of the assisting vehicle (3).
3. Disconnect the second jumper cable from the red, positive (+) battery/jumper terminal of the assisting vehicle (2).
4. Disconnect the other end of the jumper cable from the red, positive (+) jumper terminal of your vehicle (1).

i Information



An inappropriately disposed battery can be harmful to the environment and human health. Dispose of the battery according to your local law(s) or regulations.

NOTICE

To prevent damage to your vehicle:

- Only use a 12 V power supply (battery or jumper system) to jump start your vehicle.
 - Do not attempt to jump start your vehicle by push-starting.
 - Always be sure that the battery cover and cable are tightened after finishing jump start your vehicle. Otherwise it may cause damage to the relevant parts, noise trouble, or entrance of foreign substances.
-

⚠ WARNING

While jump starting your vehicle, avoid the positive (+) and negative (-) cables to come in contact. A spark could cause personal injury.

Tire pressure monitoring system (TPMS)

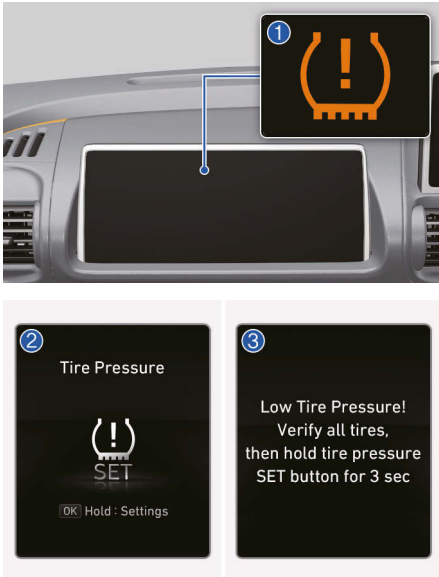

- (1) Low Tire Pressure warning light/TPMS malfunction indicator
- (2) TPMS reset
- (3) Low Tire Pressure warning message

The Tire Pressure Monitoring System (TPMS) determines whether the tire pressure is low through sensors in the wheel, which detects changes in tire radius and vibration while driving. For this system to work properly, you need to reset and save the current tire pressure. After resetting the TPMS, when one or more of your tires are under-inflated compared to the saved tire pressure, a warning light appears on the instrument cluster. A warning light also appears if there is a problem with the TPMS system.



For more information on warning lights and TPMS reset, refer to the following section in this chapter.

Resetting TPMS

To reset TPMS:

1. Adjust all tire pressure to the recommended tire inflation pressures.
2. Press the  button on the steering wheel with the vehicle parked.



3. Select **Tire Pressure** on the cluster by using the ,  (UP, DOWN) switch.
4. Press and hold the **OK** button on the steering wheel, and select **Set**.



5. Check whether the  warning light blinks for about 4 seconds.

Information

- If the "Tire pressures stored" message on the cluster does not appear or the  warning light does not blink, try again from Step 2.
- For more information on the recommended inflation pressure for your vehicle, refer to the "Tires and wheels" section in chapter 2.

For normal operation of the TPMS, be sure to reset in the following situations:

- After repairing or replacing a tire or wheel.
- After rotating the position of a tire or wheel.
- After adjusting the tire inflation pressure.
- When the Low Tire Pressure warning light is on.
- After replacing the suspension or ABS/ESC.

CAUTION

- Be sure to reset after the inflation pressure of all four tires are set to the recommended inflation pressure. If you reset without adjusting the inflation pressure, the warning sound may not activate or may activate improperly.
- If the inflation pressure of the four tires are adjusted, be sure to perform reset. Otherwise, the system may malfunction and the warning sound may not activate or may activate improperly.
- Adjust the inflation pressure when the tires are cold. A cold tire means the vehicle has not been driven for 3 hours or has been driven for less than 1.6 km (1 mi.).

Low tire pressure light



When the Low Tire Pressure warning light () illuminates and a warning message appears on the cluster for 10 seconds, one or more of your tires is significantly under-inflated.

If the warning light illuminates, reduce your speed, and also avoid hard cornering and sudden braking. We recommend that your vehicle be inspected by an authorized HYUNDAI dealer.

Check the condition and inflation pressure of all four tires, then reset the TPMS (For more information, refer to the "Resetting TPMS" section in this chapter) or take required counteractions such as repairing or replacing the tires.

When an authorized HYUNDAI dealer is not nearby, stop at a safe place and check the condition and inflation pressure of all four tires, then reset the TPMS.

If you cannot adjust the inflation pressure, use the Tire Mobility Kit (TMK) to repair or replace the under-inflated tire with a spare tire (if equipped). We recommend that your vehicle be inspected by an authorized HYUNDAI dealer.

You may not be able to identify a tire with low pressure by simply looking at it. Always use a good quality tire pressure gauge to measure. Note that a tire that is hot (from being driven) has a higher pressure measurement than a tire that is cold.

i Information

- The warning light may remain on even after replaced with a spare tire. Replace your vehicle with original sized tires. After rotating the position of a tire or wheel.
- Note that the TPMS is not a substitute for proper tire maintenance. It is the driver's responsibility to maintain the appropriate recommended inflation pressure, and the tires must be inspected periodically to maintain the recommended inflation pressure.
When the Low Tire Pressure warning light is on.
- The Low Tire Pressure warning light may illuminate when the TPMS is not reset when necessary.
- In winter or cold weather, the Low Tire Pressure warning light may illuminate if the tire pressure was adjusted to the recommended tire inflation pressure in warm weather. It does not mean your TPMS is malfunctioning because the decreased temperature leads to a proportional lowering of tire pressure. Check the tire inflation pressure and adjust the tires to the recommended tire inflation pressure.
- TPMS performance may reduce in the following situations when:
 - Reset is done incorrectly.
 - Original sized tires are not installed.
 - Driving on rough roads such as snowy, slippery roads, or unpaved roads.
 - Repeating hard cornering, sudden acceleration, or sudden braking.
 - Driving too slow or too fast.
 - The vehicle is overloaded.
 - Snow chains are installed.

WARNING

- Continued driving on low pressure tires can cause the tires to overheat and fail. Under-inflation may cause the vehicle to be unstable and reduce tire life and energy economy, increase braking distance, and other tire failures that result in loss of vehicle control. We recommend that your vehicle be inspected by an authorized HYUNDAI dealer and maintain the recommended inflation pressure.
- The TPMS cannot alert you to severe and sudden tire damage caused by external factors. If you notice any vehicle instability, immediately take your foot off the accelerator pedal, apply the brakes gradually with light force, and slowly move to a safe position off the road.

TPMS malfunction indicator

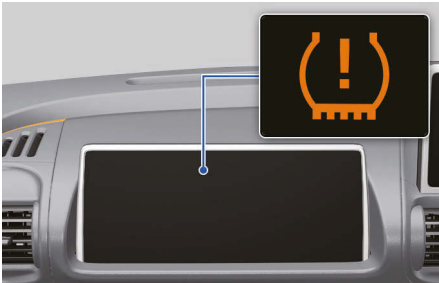

The TPMS malfunction indicator (⚠) illuminates after blinking for about 70 seconds when there is a problem with the Tire Pressure Monitoring System.

If the indicator remains illuminated even after the TPMS is reset, we recommend that your vehicle be inspected by an authorized HYUNDAI dealer as soon as possible.

If there is a malfunction with the TPMS, the under-inflated tire cannot be detected.

NOTICE

Condition	⚠ indicator status
Low pressure	Illuminate
System malfunction	Blinks for about 70 seconds and illuminate
Reset	Blinks for about 4 seconds and goes off

If you have a flat tire (with Tire Mobility Kit)



For safe operation, carefully read and follow the instructions in this manual before use.

- (1) Compressor
- (2) Sealant bottle

The tire mobility kit is a temporary fix to the tire we recommend the tire be inspected by an authorized HYUNDAI dealer or the equivalent approved for your vehicle as soon as possible.

⚠ CAUTION

When two or more tires are flat, do not use the tire mobility kit because the supported one sealant of Tire Mobility Kit is only used for one flat tire.

⚠ WARNING

Do not use the Tire Mobility Kit to repair punctures in the tire walls. This can result in an accident due to tire failure.

⚠ WARNING

Have your tire repaired as soon as possible. The tire may lose air pressure at any time after inflating with the Tire Mobility Kit.

Introduction

With the Tire Mobility Kit you stay mobile even after experiencing a tire puncture.

The compressor and sealing compound system effectively and comfortably seals most punctures in a passenger car tire caused by nails or similar objects and reinflates the tire.

After you ensure that the tire is properly sealed you can drive cautiously on the tire (distance up to 200 km (120 mi.)) at a max. speed of 80 km/h (50 mph) in order to reach a service station or tire dealer for the tire replacement.

It is possible that some tires, especially with larger punctures or damage to the sidewall, cannot be sealed completely.

Air pressure loss in the tire may adversely affect tire performance.

For this reason, you should avoid abrupt steering or other driving maneuvers, especially if the vehicle is heavily loaded or if a trailer is in use.

The Tire Mobility Kit is not designed or intended as a permanent tire repair method and is to be used for one tire only.

This instruction shows you step by step how to temporarily seal the puncture simply and reliably.

Read the section Notes on the safe use of the Tire Mobility Kit.

WARNING

Do not use the TMK if a tire is severely damaged by driving run flat or with insufficient air pressure.

Only punctured areas located within the tread region of the tire can be sealed using the TMK.

Notes on the safe use of the Tire Mobility Kit

- Park your car at the side of the road so that you can work with the Tire Mobility Kit away from moving traffic.
- To be sure your vehicle will not move, even when you are on fairly level ground, always set your parking brake.
- Only use the Tire Mobility Kit for sealing/inflation passenger car tires. Only punctured areas located within the tread region of the tire can be sealed using the tire mobility kit.
- Do not use on motorcycles, bicycles or any other type of tires.
- When the tire and wheel are damaged, do not use Tire Mobility Kit for your safety.
- Use of the Tire Mobility Kit may not be effective for tire damage larger than about 4 mm (0.16 in.).
- If the tire cannot be made roadworthy with the Tire Mobility Kit, we recommend that you contact an authorized HYUNDAI dealer.
- Do not use the Tire Mobility Kit if a tire is severely damaged by driving run flat or with insufficient air pressure.
- Do not remove any foreign objects such as nails or screws that have penetrated the tire.
- Provided the car is outdoors, leave the vehicle is ON (READY indicator ON). Otherwise operating the compressor may eventually drain the car battery.
- Never leave the Tire Mobility Kit unattended while it is being used.
- Do not leave the compressor running for more than 10 minutes at a time or it may overheat.

Emergency situations

- Do not use the Tire Mobility Kit if the ambient temperature is below -30 °C (-22 °F).
- In case of skin contact with the sealant, wash the area thoroughly with plenty of water. If the irritation persists, seek medical attention.
- In case of eye contact with the sealant, flush your eyes for at least 15 minutes. If the irritation persists, seek medical attention.
- In case of swallowing the sealant, rinse the mouth and drink plenty of water. However, never give anything to an unconscious person and seek medical attention immediately.
- Long time exposure to the sealant may cause damage to bodily tissue such as kidney, etc.

Components of the Tire Mobility Kit

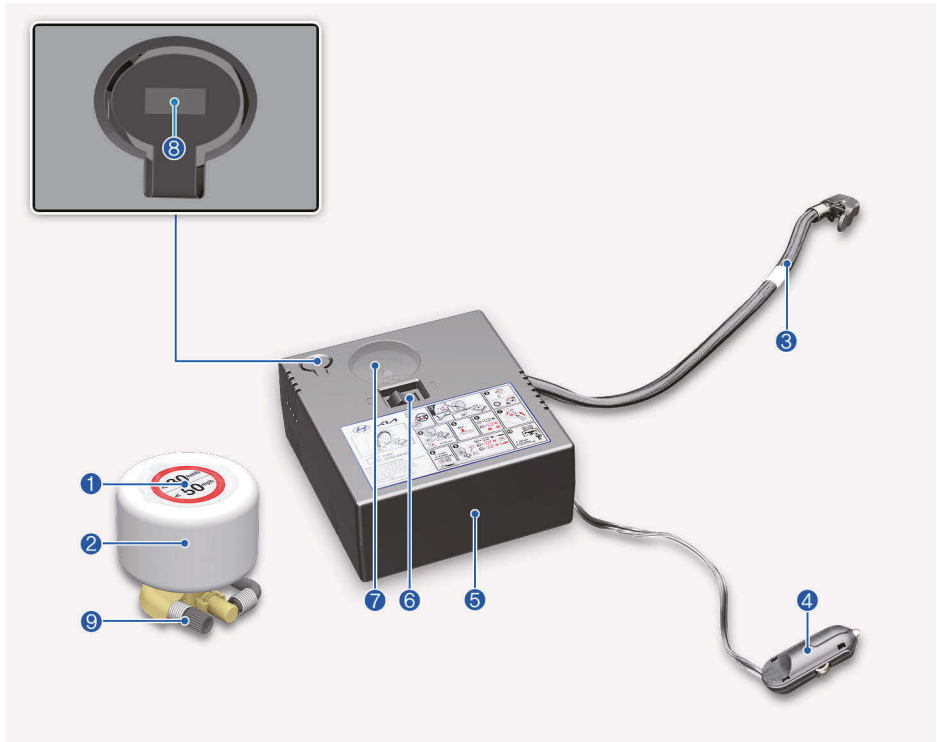

- (1) Speed-restriction label
- (2) Sealant bottle and label with speed restriction
- (3) Filling hose
- (4) Compressor power cord
- (5) Compressor
- (6) ON/OFF switch
- (7) Pressure gauge for displaying the tire inflation pressure
- (8) Tire inflation pressure control button
- (9) Sealant injection hose

Connectors, cable and connection hose are stored in the compressor housing. Strictly follow the specified sequence, otherwise the sealant may escape under high pressure.

WARNING

Expired sealant

Do not use the Tire sealant after the sealant has expired (for example, pasted the expiration date on the sealant container). This can increase the risk of tire failure.

WARNING

Sealant

- Keep out of reach of children.
- Avoid contact with eyes.
- Do not swallow.

Using the Tire Mobility Kit when a tire is flat

CAUTION



Detach the speed restriction label (1) from the sealant bottle (2), and place it in a highly visible place inside the vehicle such as on the steering wheel to remind the driver not to drive too fast.

CAUTION

If only the tire pressure needs to be adjusted, refer to the "How to adjust tire pressure" section in this chapter.

Before using the Tire Mobility Kit, be fully aware of the explanation on the sealant.

1. Shake the sealant bottle (2).



2. Connect and secure filling hose (3) to the sealant bottle connection [A]. Stand the sealant bottle with the filling hose facing upward.

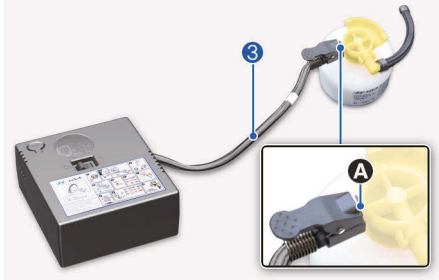

3. Unscrew the tire valve cap of the damaged tire and connect the sealant injection hose (9) to the tire valve.



4. Make sure the compressor ON/OFF switch (6) is turned off and then plug the compressor power cord (4) into the vehicle power outlet.



⚠ CAUTION

Do not connect other vehicle's tire mobility kit to the vehicle power outlet. Differences in current capacity may cause fire.

⚠ CAUTION

Securely install the sealant filling hose to the valve. If not, sealant may flow backward, possibly clogging the filling hose.

5. With the vehicle ON (READY indicator ON), switch on the compressor and let it run for about 5-7 minutes to fill the sealant up to proper pressure. (refer to the "Tires and wheels" section in chapter 2). Be careful not to overinflate the tire and stay away from the tire when filling it.

⚠ CAUTION

Refer to the proper tire pressure listed in "Tires and wheels" section in chapter 2 or the tire pressure label attached to the driver's seat B pillar.

Do not attempt to drive your vehicle if the tire pressure is below 200 kPa (29 psi). This could result in an accident due to sudden tire failure.

Use of the TMK may be ineffectual for tire damage larger than about 4 mm (0.16 in.).

6. Switch off the compressor.
7. Detach the hoses from the sealant bottle connector and from the tire valve.

Return the Tire Mobility Kit to its storage location in the vehicle.

8. Immediately drive about 7-10 km (4-6 mi. or, about 10 minutes) to evenly distribute the sealant in the tire.

! CAUTION

Do not exceed a speed of 80 km/h (50 mph). If possible, do not fall below a speed of 20 km/h (12 mph).

While driving, if you experience any unusual vibration, ride disturbance or noise, reduce your speed and drive with caution until you can safely pull off of the side of the road.

Call for road side service or towing.

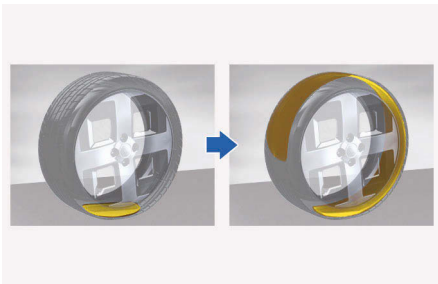

9. After driving about 7-10 km (4-6 mi. or about 10 minutes), stop at a safety location.
10. Check the tire pressure and adjust it to proper pressure.

NOTICE

Do not let the compressor run for more than 10 minutes, otherwise the device will overheat and may be damaged.

i Information

The pressure gauge may show higher than actual reading when the compressor is running. To get an accurate tire reading, the compressor needs to be turned off.

! CAUTION

If the air pressure does not remain constant, drive again for 7-10 km (4-6 mi) or 10 minutes at a speed of 20 km/h (12 mph) or higher and then adjust the tire pressure

Use of the TMK may be ineffectual for tire damage larger than about 4 mm (0.16 in.).

We recommend that you contact an authorized HYUNDAI dealer if the tire cannot be made roadworthy with the Tire Mobility Kit.

! WARNING

The tire inflation pressure must be at least 220 kPa (32 psi). If it is not, do not continue driving.

Call for road side service or towing.

i Information

When reinstalling the repaired or replaced tire and wheel on the vehicle, tighten the wheel nut to 11-13 kgf·m (79-94 lbf·ft).

How to adjust tire pressure

1. Park your vehicle in a safe location.
2. Connect the filling hose (3) of the compressor directly to the tire valve.



3. Plug the compressor power cord (4) into the vehicle power outlet.
4. Adjust the tire inflation pressure to the recommended tire inflation.

With the vehicle is ON (READY indicator ON), proceed as follows.

- To increase the inflation pressure: Switch on the compressor. To check the current inflation pressure setting, briefly switch off the compressor.
- To reduce the inflation pressure : Press the tire inflation pressure control button (8).

NOTICE

Do not let the compressor run for more than 10 minutes, otherwise the device will overheat and may be damaged.

i Information

- The pressure gauge may show higher than actual reading when the compressor is running. To get an accurate tire reading, the compressor needs to be turned off.
- When reinstalling the repaired or replaced tire and wheel on the vehicle, tighten the wheel nut to 11-13kgf·m (79-94 lbf·ft).

CAUTION

Do not use the sealant when the tire pressure only needs to be adjusted.

WARNING

The tire inflation pressure must be at least 220 kPa (32 psi). If it is not, do not continue driving.

Call for road side service or towing.

Towing

Towing service

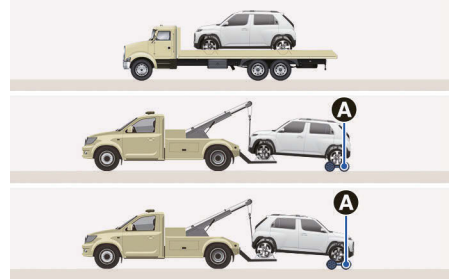

[A] Dollies

If emergency towing is necessary, we recommend having it done by an authorized HYUNDAI dealer or a commercial tow-truck service.

Proper lifting and towing procedures are necessary to prevent damage to the vehicle. The use of wheel dollies or flatbed is recommended.

It is acceptable to tow the vehicle with the rear wheels on the ground (without dollies) and the front wheels off the ground.

If any of the loaded wheels or suspension components are damaged or the vehicle is being towed with the front wheels on the ground, use a towing dolly under the front wheels.

When being towed by a commercial tow truck and wheel dollies are not used, the front of the vehicle should always be lifted, not the rear.

CAUTION

- Do not tow the vehicle with the front wheels on the ground as this may cause damage to the vehicle.



- Do not tow vehicles with sling-type equipment. Only use wheel lift or flatbed equipment.



- Do not lift using the trailer hitch or body and chassis part.

Precautions when moving a short distance before towing a vehicle

Move short distances within 10 m (33 ft.) at a speed of 5 km/h (3 mph) or less only when loading on a tow truck or if the vehicle needs to be repositioned.

At this time, the gear must be in the N (Neutral) position and the parking brake must be released. If it is impossible to operate the reduction gear and parking brake, move the vehicle with the front wheel lifted.

NOTICE

Do not lift the vehicle by the tow fitting or body and chassis parts. Otherwise the vehicle may be damaged.

Removable towing hook

1. Open the tailgate, and remove the towing hook (1) from the tool case.

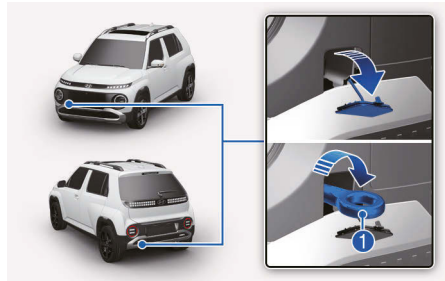

2. Remove the hole cover.
3. Push the lower part of the bumper hole cover.
 - Push the upper part of the bumper hole cover.
 - Pull the lower part of the bumper hole cover.
4. Install the towing hook by turning it clockwise into the hole until it is fully secured.
5. Remove the towing hook and install the cover after use.

NOTICE

Failure to properly tighten the towing hook may result in vehicle damage and deformation of related parts.

CAUTION

Make sure the towing hook is tightened properly. If not, during towing the towing hook may be thrown off the vehicle resulting in serious injury or accident.

Emergency commodity

 if equipped

Your vehicle is equipped with emergency commodities to help you respond to emergency situation.

Fire extinguisher

NOTICE

This vehicle is equipped with the powder-type fire extinguisher exclusively for the fire caused by the electricity in the vehicle. Using water or other inappropriate fire extinguisher may cause the electric shock and collateral damage. If the fire cannot be controlled by the fire extinguisher equipped in the vehicle, avoid approaching to the fire and call fire station. Make sure to announce that the fire is caused by the electric vehicle.

If there is small fire and you know how to use the fire extinguisher, follow these steps carefully.

1. Pull out the safety pin at the top of the extinguisher that keeps the handle from being accidentally pressed.
2. Aim the nozzle towards the base of the fire.
3. Stand about 2.5 m (8 ft) away from the fire and squeeze the handle to discharge the extinguisher. If you release the handle, the discharge will stop.
4. Sweep the nozzle back and forth at the base of the fire. After the fire appears to be out, watch carefully since it may re-ignite.

First aid kit

Supplies for use in giving first aid such as scissors, bandage and adhesive tape, etc., are provided.

Triangle reflector

Place the triangle reflector on the road to warn oncoming vehicles during emergencies, such as when the vehicle is parked by the roadside due to problems.

Tire pressure gauge

 if equipped

Tires normally lose some air in day-to-day use, and you may have to add a air periodically and usually it is not a sign of a leaking tire, but of normal wear. Always check tire pressure when the tires are cold because tire pressure increases with temperature.

To check the tire pressure, take the following steps:

1. Unscrew the inflation valve cap that is located on the rim of the tire.
2. Press and hold the gauge against the tire valve. Some air will leak as you begin and more will leak if you don't press the gauge in firmly.
3. A firm non-leaking push will activate the gauge.
4. Read the tire pressure on the gauge to see whether the tire pressure is low or high.
5. Adjust the tire pressure to the specified pressure. Refer to the "Tires and wheels" section in chapter 2.
6. Reinstall the inflation valve cap.



WARNING

- When an accident occur, park the vehicle to a safe place. To avoid the leak of electricity in high voltage battery, turn the vehicle off and pull the yellow label in the high voltage battery switch to shut down the high voltage battery. Also, disconnect the auxiliary battery(12 V) cable to shut down. Be sure to disconnect both (+) cable and (-) cable.
 - Do not touch the exposed electric wires. Do not touch high voltage wires (orange), connectors and other electric components.
 - When an accident occur, the lethal gas and fluid from damaged high voltage battery can be leaked. Be aware not to touch or exposed to the gas and fluid. When flammable or poison gas leak inside the vehicle, open windows and evacuate to a safe place. When leaked fluid comes in contact with your eyes, flush your eyes with clean water. When the fluid contacts with your skin, wash it with salt water. Get immediate medical attention afterward.
 - When the vehicle is flooded, immediately turn the vehicle off and evacuate to a safe place. For your safety we recommend to call the fire station and or contact an authorized HYUNDAI dealer.
 - When the fire spread to the high voltage battery, the additional fire may occur. In this situation, be sure to accompany a fire truck when the vehicle is being towed.
-

Pan-European eCall System (FOR EUROPE)

+ if equipped

The vehicle is equipped with a device* connected with the Pan-European eCall system for making emergency call to response teams. The Pan-European eCall system is an automatic emergency call service made in event of a traffic accident or other** accidents on the roads of Europe. (only in countries with regulation on this system)

The system allows contacting with an officer of the single duty dispatch service in case of accidents on the roads of Europe. (only in countries with regulation on this system)

The Pan-European eCall system given conditions, stated in the Owner's Manual as well as Warranty and Service book transmits data to the Public Safety Answering Point (PSAP) including such information as vehicle location, vehicle type, VIN (vehicle identification number of the vehicle).

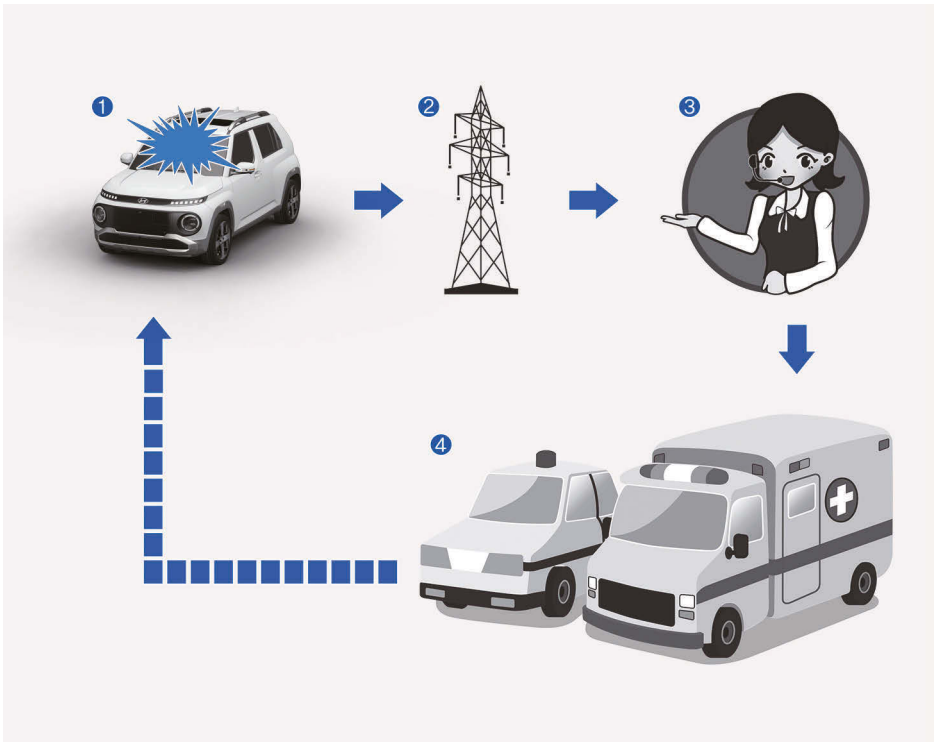

- (1) Road accident
- (2) Wireless network
- (3) Public Safety Answering Point (PSAP)
- (4) Rescue

i Information

Pan-European eCall device in the Owner's Manual means equipment, installed in the vehicle, which provides connection with the Pan-European eCall system.

"Other accidents" mean any accidents on the roads of Europe (only in countries with regulation on this system) resulted in injured people and/or necessity of provision of assistance. In case of registration of any accident, it is necessary to stop a vehicle, press button SOS (location of the button is specified on the picture in the chapter "Pan-European eCall (if equipped)") of the Owner's Manual. When making a call, the system gathers information about the vehicle (from which a call was made), after which connects the car with an officer of the Public Safety Answering Point (PSAP) to tell about the reason of the emergency call.

Once the data which is stored in the Pan-European eCall system is delivered to the rescue center to assist the driver and passengers with proper rescue operations, the data will be deleted after rescue operation is completed.

Description of the eCall in-vehicle system (For Europe)

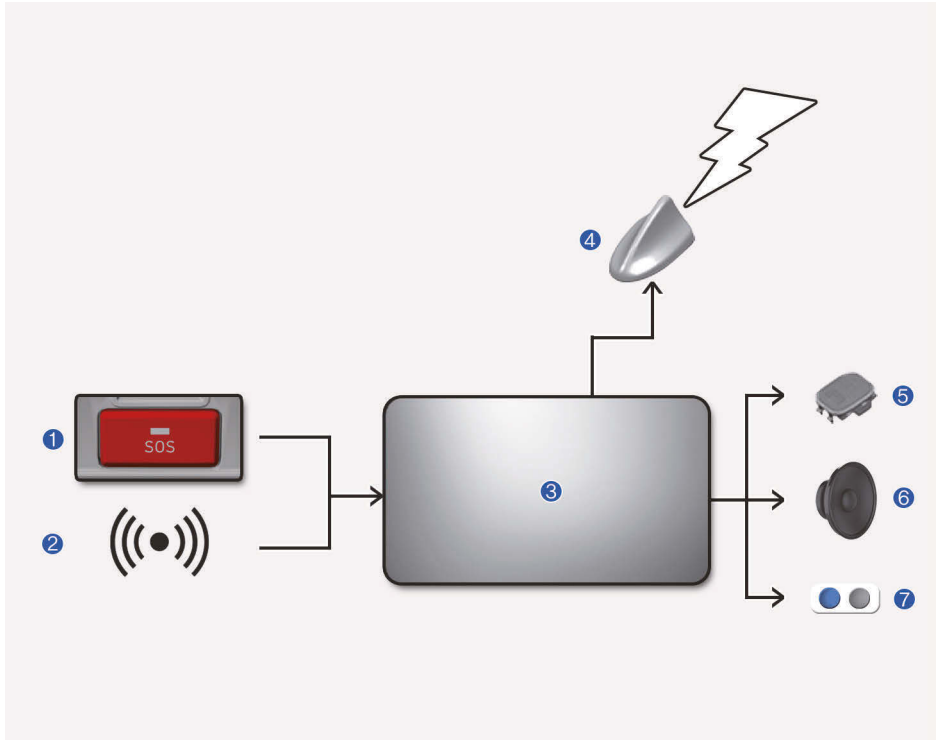

- (1) SOS button
- (2) Crash signal
- (3) Emergency Call System
- (4) Antenna
- (5) Mic
- (6) Speaker
- (7) LEDs

Overview of the 112-based eCall in-vehicle system, its operation and functionalities: refer to this section. The 112-based eCall service is a public service of general interest and is accessible free of charge.

The 112-based eCall in-vehicle system is activated by default. It is activated automatically by means of in-vehicle sensors in the event of a severe accident.

It will also be triggered automatically when the vehicle is equipped with a TPS system which does not function in the event of a severe accident.

The 112-based eCall in-vehicle system can also be triggered manually, if needed. Instructions for manual activation of the system: refer to this section.

In the event of a critical system failure that would disable the 112-based eCall in-vehicle system, the following warning will be given to the occupants of the vehicle: refer to this section.

Information on data processing (For Europe)

Any processing of personal data through the 112-based eCall in-vehicle system shall comply with the personal data protection rules provided for in Directives 95/46/EC (1) and 2002/58/EC (2) of the European Parliament and of the Council, and in particular, shall be based on the necessity to protect the vital interests of the individuals in accordance with Article 7 (d) of Directive 95/46/EC (3).

Processing of such data is strictly limited to the purpose of handling the emergency eCall to the single European emergency number 112.

Types of data and its recipients

The 112-based eCall in-vehicle system may collect and process only the following data:

- Vehicle Identification Number
- Vehicle type (passenger vehicle or light commercial vehicle)
- Vehicle propulsion storage type (gasoline/diesel/CNG/LPG/electric/hydrogen)
- Vehicle recent locations and direction of travel
- Log file of the automatic activation of the system and its timestamp
- Any additional data (if applicable): Not applicable

Recipients of data processed by the 112-based eCall in-vehicle system are the relevant public safety answering points designated by the respective public authorities of the country on which territory they are located, to first receive and handle eCalls to the single European emergency number 112. Additional information (if available): Not applicable

1. Directive 95/46/EC of the European Parliament and of the Council of 24 October 1995 on the protection of individuals with regard to the processing of personal data and on the free movement of such data (OJ L 281, 23.11.1995, p. 31).
2. Directive 2002/58/EC of the European Parliament and of the Council of 12 July 2002 concerning the processing of personal data and the protection of privacy in the electronic communications sector (Directive on privacy and electronic communications) (OJ L 201, 31.7.2002, p. 37).
3. Directive 95/46/EC is repealed by Regulation (EU) 2016/679 of the European Parliament and of the Council of 27 April 2016 on the protection of natural persons with regard to the processing of personal data and on the free movement of such data (General Data Protection Regulation) (OJ L 119, 4.5.2016, p. 1). The Regulation applies from 25 May 2018.

Arrangements for data processing

The 112-based eCall in-vehicle system is designed in such a way as to ensure that the data contained in the system memory is not available outside the system before an eCall is triggered. Additional remarks (if any): Not applicable

The 112-based eCall in-vehicle system is designed in such a way as to ensure that it is not traceable and not subject to any constant tracking in its normal operation status.

Additional remarks (if any): Not applicable

The 112-based eCall in-vehicle system is designed in such a way as to ensure that data in the system internal memory is automatically and continuously removed.

The vehicle location data is constantly overwritten in the internal memory of the system so as always to keep maximum of the last three up-to-date locations of the vehicle necessary for the normal functioning of the system.

The log of activity data in the 112-based eCall in-vehicle system is kept for no longer than necessary for attaining the purpose of handling the emergency eCall and in any case not beyond 13 hours from the moment an emergency eCall was initiated. Additional remarks (if any): Not applicable

Modalities for exercising data subject's rights

The data subject (the vehicle's owner) has a right of access to data and as appropriate to request the rectification, erasure or blocking of data, concerning him or her, the processing of which does not comply with the provisions of Directive 95/46/EC. Any third parties to whom the data have been disclosed have to be notified of such rectification, erasure or blocking carried out in compliance with this Directive, unless it proves impossible or involves a disproportionate effort.

The data subject has a right to complain to the competent data protection authority if he or she considers that his or her rights have been infringed as a result of the processing of his or her personal data.

Contact service responsible for handling access requests (if any): Not applicable

Pan-European eCall System (For Europe)



Elements of the Pan-European eCall system, installed in passenger compartment:

- (1) SOS button
- (2) LED

SOS button: the driver/passenger makes an emergency call to the single duty dispatch service by pressing the button.

LED: The LED illuminates for 3 seconds when the Start/Stop button is in the ON position. After that they will switch off at normal operation of the system.

If there are some problems in the system, the SOS indicator light illuminates in the instrument cluster.

Automatic accident reporting (For Europe)

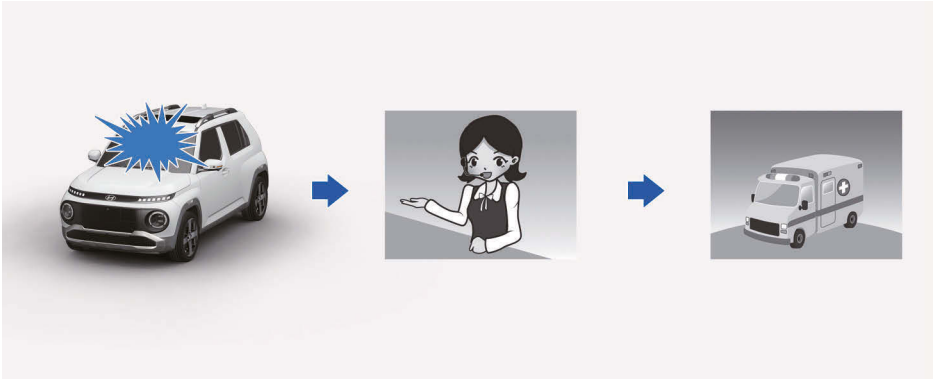

The Pan-European eCall device automatically makes an emergency call to the Public Safety Answering Point (PSAP) for proper rescuing operations in event of vehicle accident.

For proper emergency services and support the Pan-European eCall system automatically transmits the accident data to the Public Safety Answering Point (PSAP) when a traffic accident is detected.

In this case, the emergency call cannot be hung up by pressing the SOS button and the Pan-European eCall system remains connected until the emergency service officer, receiving the call, disconnects the emergency call.

In minor traffic accidents the Pan-European eCall system may not execute an emergency call. However, an emergency call may be made manually by pressing the SOS button.

CAUTION

Operation of the system is impossible in case of absence of cellular transmission and GPS and Galileo signals.

Manual accident reporting (For Europe)

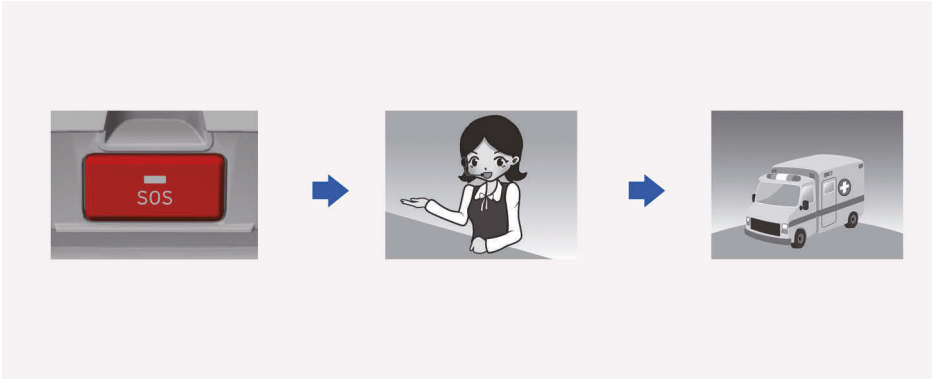

The driver or passenger manually can make an emergency call in the Public Safety Answering Point (PSAP), by pressing SOS button to call the necessary emergency services.

A call to the emergency services through the Pan-European eCall system can be canceled by pressing the SOS button again only before the call connection.

After activation of emergency call in the manual mode (for proper emergency services and support), the Pan-European eCall system automatically transmits the road accident data / or data on other accident to the officer of the Public Safety Answering Point (PSAP) (during emergency call) by pressing the SOS button.

If the driver or passenger accidentally presses the SOS button, it can be canceled by pressing the button again. (For Russia)

It can be canceled by pressing the button again in 3 seconds. It can't be canceled after that. (Except Russia)

In case of road accident or other accident for activation of emergency call in manual mode it is necessary:

1. Stop the vehicle in accordance with traffic rules to ensure safety to yourself and other participants of road traffic;
2. Press the SOS button, when pressing the button SOS registration of the device in the wireless telephonic communication networks is carried out, minimum data set about vehicle and its location is collected in accordance with of the technical requirements of the device. After that connection with the officer of the Pan-European eCall system is made for clearing up reasons (conditions) of the emergency call.
3. After clearing up reasons of the emergency call, the officer of the Public Safety Answering Point (PSAP) sends emergency services and completes the emergency call.

If the emergency call is not carried out in accordance with the procedure, mentioned above, the emergency call will be considered as erroneous.

⚠ WARNING

Emergency power supply of the Pan-European eCall system from the battery

- The Pan-European eCall system battery supplies power during 1 hour in case main power source of the vehicle is cut off due to the collision during the emergency situations.
- The Pan-European eCall system battery should be replaced every 4 years. For more information refer to the "Scheduled maintenance services" in chapter 9.

LED illumination in red (system malfunction)

If red LED illuminates in normal driving conditions, this can indicate malfunction of the Pan-European eCall system. We recommend to have the Pan-European eCall system checked at an authorized HYUNDAI dealer.

Otherwise correct operation of the Pan-European eCall system device, installed in your vehicle is not guaranteed. Owner of the vehicle incurs liability for consequences, occurred as a result of nonobservance of conditions, mentioned above.

Arbitrary Removal or Modification

The Pan-European eCall system calls emergency services for assistance. Thus, any arbitrary removal or changes to the Pan-European eCall system settings may affect your driving safety. Also, it may even make an erroneous emergency call to the Public Safety Answering Point (PSAP). Thereby, we kindly ask you not to make any changes by yourself or by the third parties in the settings of the equipment of the Pan-European eCall system, installed in your vehicle.

NOTICE

The mobile network operators will phase out the 2G and 3G in many countries around the world. The decision to phase out 2G and/or 3G network technology was solely at the discretion of mobile network operators and therefore beyond the control of HYUNDAI. Due to decision of the network operators to discontinue their 2G and/or 3G, the automatic/manual eCall will no longer be available in the event of an accident or a situation requiring an emergency service.

UAE eCall System (For UAE)

 If equipped

The vehicle is equipped with a device* connected with the UAE eCall system for making emergency call to response teams. The UAE eCall system is an automatic emergency call service made in event of a traffic accident or other** accidents on the roads. (only in countries with regulation on this system)

The system allows contacting with an officer of the single duty dispatch service in case of accidents on the roads. (only in countries with regulation on this system)

The UAE eCall system given conditions, stated in the Owner's Manual as well as Warranty and Service book transmits data to the Public Safety Answering Point (PSAP) including such information as vehicle location, vehicle type, VIN (vehicle identification number of the vehicle).

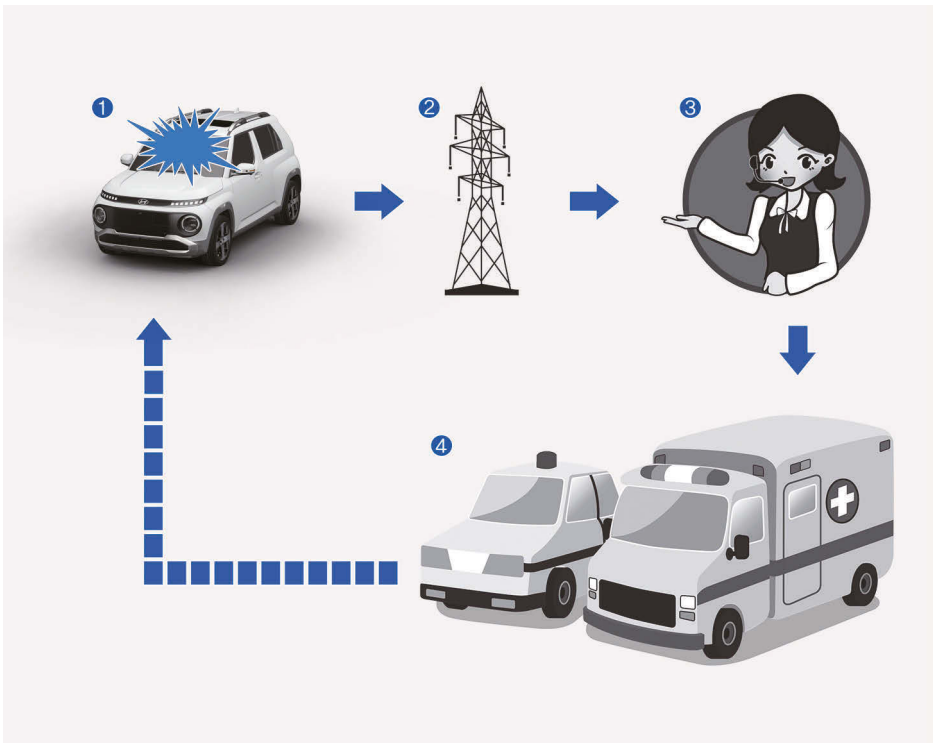

- (1) Road accident
- (2) Wireless network
- (3) Public Safety Answering Point (PSAP)
- (4) Rescue

i Information

UAE eCall device in the Owner's Manual means equipment, installed in the vehicle, which provides connection with the UAE eCall system.

"Other accidents" mean any accidents on the roads UAE (only in countries with regulation on this system) resulted in injured people and/or necessity of provision of assistance. In case of registration of any accident, it is necessary to stop a vehicle, press button SOS (location of the button is specified on the picture in the chapter "UAE eCall (IF EQUIPPED)") of the Owner's Manual. When making a call, the system gathers information about the vehicle (from which a call was made), after which connects the car with an officer of the Public Safety Answering Point (PSAP) to tell about the reason of the emergency call.

Once the data which is stored in the UAE eCall system is delivered to the rescue center to assist the driver and passengers with proper rescue operations, the data will be deleted after rescue operation is completed.

Description of the eCall in-vehicle system (For UAE)

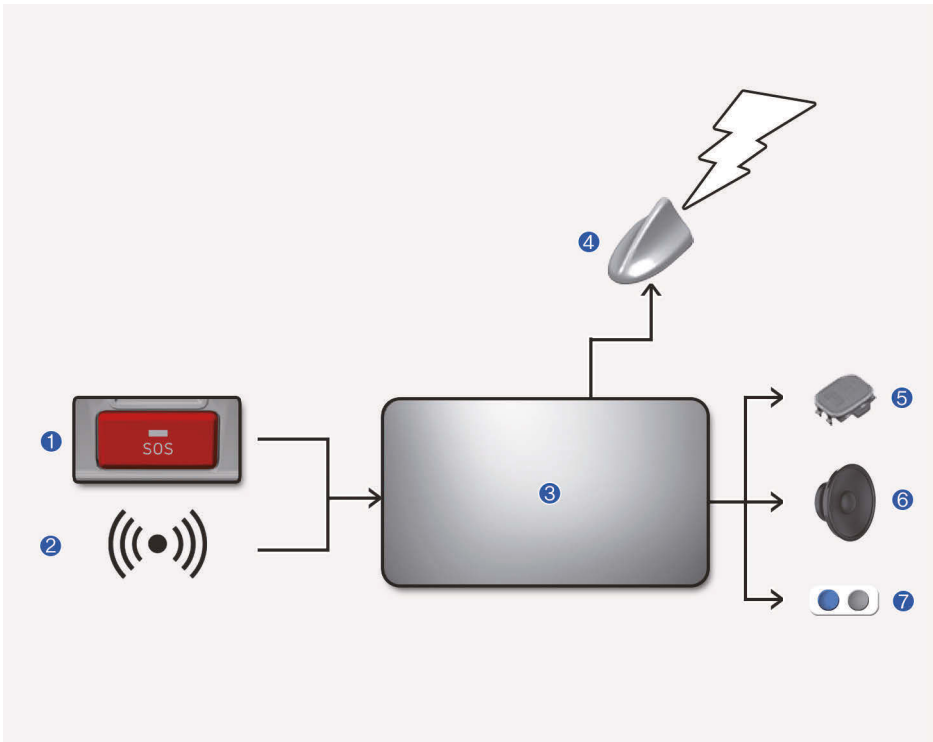

- (1) SOS Button
- (2) Crash signal
- (3) Emergency Call System
- (4) Antenna
- (5) Mic
- (6) Speaker
- (7) LEDs

Overview of the 999-based eCall in-vehicle system, its operation and functionalities: refer to this section. The 999-based eCall service is a public service of general interest and is accessible free of charge.

The 999-based eCall in-vehicle system is activated by default. It is activated automatically by means of in-vehicle sensors in the event of a severe accident.

It will also be triggered automatically when the vehicle is equipped with a TPS system which does not function in the event of a severe accident.

The 999-based eCall in-vehicle system can also be triggered manually, if needed. Instructions for manual activation of the system: refer to this section.

In the event of a critical system failure that would disable the 999-based eCall in-vehicle system, the following warning will be given to the occupants of the vehicle: refer to this section.

Information on data processing (For UAE)

Any processing of personal data through the 999-based eCall in-vehicle system shall comply with the personal data protection rules provided for in Directives 95/46/EC (1) and 2002/58/EC (2) of the European Parliament and of the Council, and in particular, shall be based on the necessity to protect the vital interests of the individuals in accordance with Article 7(d) of Directive 95/46/EC (3).

Processing of such data is strictly limited to the purpose of handling the emergency eCall to the single UAE emergency number 999.

Types of data and its recipients

The 999-based eCall in-vehicle system may collect and process only the following data:

- Vehicle Identification Number
- Vehicle type (passenger vehicle or light commercial vehicle)
- Vehicle propulsion storage type (gasoline/diesel/CNG/LPG/electric/hydrogen)
- Vehicle recent locations and direction of travel
- Log file of the automatic activation of the system and its timestamp
- Any additional data (if applicable): Not applicable

Recipients of data processed by the 999-based eCall in-vehicle system are the relevant public safety answering points designated by the respective public authorities of the country on which territory they are located, to first receive and handle eCalls to the single UAE emergency number 999. Additional information (if available): Not applicable

1. Directive 95/46/EC of the European Parliament and of the Council of 24 October 1995 on the protection of individuals with regard to the processing of personal data and on the free movement of such data (OJ L 281, 23.11.1995, p. 31).
2. Directive 2002/58/EC of the European Parliament and of the Council of 12 July 2002 concerning the processing of personal data and the protection of privacy in the electronic communications sector (Directive on privacy and electronic communications) (OJ L 201, 31.7.2002, p. 37).
3. Directive 95/46/EC is repealed by Regulation (EU) 2016/679 of the European Parliament and of the Council of 27 April 2016 on the protection of natural persons with regard to the processing of personal data and on the free movement of such data (General Data Protection Regulation) (OJ L 119, 4.5.2016, p. 1). The Regulation applies from 25 May 2018.

Arrangements for data processing

The 999-based eCall in-vehicle system is designed in such a way as to ensure that the data contained in the system memory is not available outside the system before an eCall is triggered. Additional remarks (if any): Not applicable

The 999-based eCall in-vehicle system is designed in such a way as to ensure that it is not traceable and not subject to any constant tracking in its normal operation status. Additional remarks (if any): Not applicable

The 999-based eCall in-vehicle system is designed in such a way as to ensure that data in the system internal memory is automatically and continuously removed.

The vehicle location data is constantly overwritten in the internal memory of the system so as always to keep maximum of the last three up-to-date locations of the vehicle necessary for the normal functioning of the system.

The log of activity data in the 999-based eCall in-vehicle system is kept for no longer than necessary for attaining the purpose of handling the emergency eCall and in any case not beyond 13 hours from the moment an emergency eCall was initiated. Additional remarks (if any): Not applicable

Modalities for exercising data subject's rights

The data subject (the vehicle's owner) has a right of access to data and as appropriate to request the rectification, erasure or blocking of data, concerning him or her, the processing of which does not comply with the provisions of Directive 95/46/EC. Any third parties to whom the data have been disclosed have to be notified of such rectification, erasure or blocking carried out in compliance with this Directive, unless it proves impossible or involves a disproportionate effort.

The data subject has a right to complain to the competent data protection authority if he or she considers that his or her rights have been infringed as a result of the processing of his or her personal data.

Contact service responsible for handling access requests (if any): Not applicable

UAE eCall System (For UAE)



Elements of the UAE eCall System, installed in passenger compartment:

- (1) SOS button
- (2) LED

SOS button: the driver/passenger makes an emergency call to the single duty dispatch service by pressing the button.

LED: The LED illuminates for 3 seconds when the Start/Stop button is in the ON position. After that they will switch off at normal operation of the system.

If there are some problems in the system, the SOS indicator light illuminates in the instrument cluster.

Automatic accident reporting (For UAE)

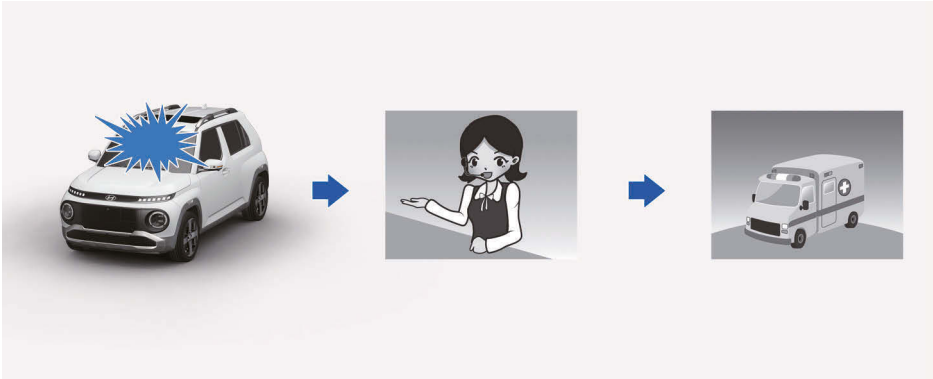

The UAE eCall device automatically makes an emergency call to the Public Safety Answering Point (PSAP) for proper rescuing operations in event of vehicle accident.

For proper emergency services and support the UAE eCall system automatically transmits the accident data to the Public Safety Answering Point (PSAP) when a traffic accident is detected.

In this case, the emergency call cannot be hung up by pressing the SOS button and the UAE eCall system remains connected until the emergency service officer, receiving the call, disconnects the emergency call.

In minor traffic accidents the UAE eCall system may not execute an emergency call. However, an emergency call may be made manually by pressing the SOS button.

⚠ CAUTION

Operation of the system is impossible in case of absence of mobile transmission and GPS and Galileo signals.

Manual accident reporting

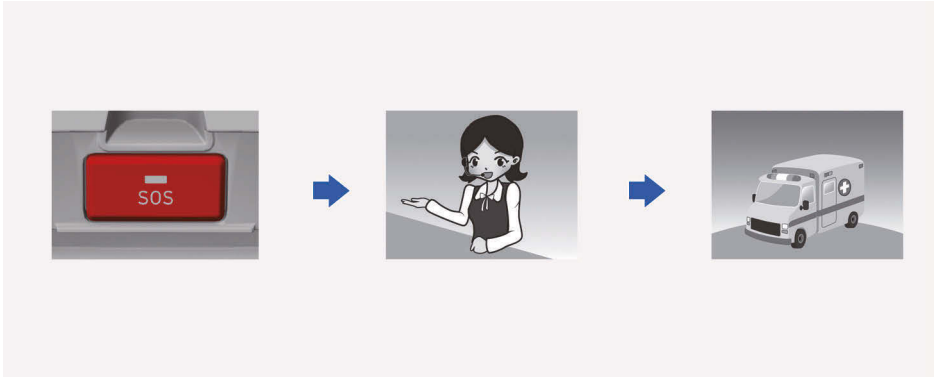

The driver or passenger manually can make an emergency call in the Public Safety Answering Point (PSAP), by pressing SOS button to call the necessary emergency services.

A call to the emergency services through the UAE eCall system can be cancelled by pressing the SOS button again only before the call connection.

After activation of emergency call in the manual mode (for proper emergency services and support), the UAE eCall system automatically transmits the road accident data / or data on other accident to the officer of the Public Safety Answering Point (PSAP) (during emergency call) by pressing the SOS button.

If the driver or passenger accidentally presses the SOS button, it can be canceled by pressing the button again. (For Russia)

It can be canceled by pressing the button again in 3 seconds. It can't be canceled after that. (Except Russia)

In case of road accident or other accident for activation of emergency call in manual mode it is necessary:

1. Stop the vehicle in accordance with traffic rules to ensure safety to yourself and other participants of road traffic;
2. Press the SOS button, when pressing the button SOS registration of the device in the wireless telephonic communication networks is carried out, minimum data set about vehicle and its location is collected in accordance with of the technical requirements of the device. After that connection with the officer of the UAE eCall system is made for clearing up reasons (conditions) of the emergency call.
3. After clearing up reasons of the emergency call, the officer of the Public Safety Answering Point (PSAP) sends emergency services and completes the emergency call.

If the emergency call is not carried out in accordance with the procedure, mentioned above, the emergency call will be considered as erroneous.

WARNING

Emergency power supply of the UAE eCall system from the battery

- The UAE eCall system battery supplies power during 1 hour in case main power source of the vehicle is cut off due to the collision during the emergency situations.
- The UAE eCall system battery should be replaced every 4 years. For more information refer to the "Scheduled maintenance services" section in chapter 9.

LED illumination in red (system malfunction)

If red LED illuminates in normal driving conditions, this can indicate malfunction of the UAE eCall system. We recommend to have the UAE eCall system checked at an authorized HYUNDAI dealer.

Otherwise correct operation of the UAE eCall system device, installed in your vehicle is not guaranteed. Owner of the vehicle incurs liability for consequences, occurred as a result of nonobservance of conditions, mentioned above.

Arbitrary Removal or Modification

The UAE eCall system calls emergency services for assistance. Thus, any arbitrary removal or changes to the UAE eCall system settings may affect your driving safety. Also, it may even make an erroneous emergency call to the Public Safety Answering Point (PSAP). Thereby, we kindly ask you not to make any changes by yourself or by the third parties in the settings of the equipment of the UAE eCall system, installed in your vehicle.

eCall certification label



9. Maintenance

Motor compartment.....	9-3
Maintenance services	9-4
Owner's responsibility	9-4
Owner maintenance precautions	9-4
Owner maintenance.....	9-5
Owner maintenance schedule	9-5
Scheduled maintenance services.....	9-7
Normal maintenance schedule.....	9-8
Maintenance under severe usage conditions.....	9-10
Explanation of scheduled maintenance items	9-11
Cooling system.....	9-11
Coolant	9-11
Reduction gear fluid	9-11
Brake hoses and lines	9-11
Brake fluid.....	9-11
Brake discs, pads, calipers and rotors.....	9-11
Suspension mounting bolts.....	9-11
Steering gear box, linkage & boots/lower arm ball joint.....	9-11
Drive shafts and boots.....	9-11
Air conditioning refrigerant.....	9-11
Coolant	9-12
Changing coolant.....	9-13
Brake fluid	9-14
Checking the brake fluid level.....	9-14
Reduction gear fluid	9-15
Washer fluid	9-15
Checking the washer fluid level.....	9-15
Cabin air filter.....	9-16
Filter inspection	9-16
Filter replacement.....	9-16
Wiper blades	9-17
Blade inspection	9-17
Blade replacement.....	9-17
Battery (12 V).....	9-19

For best battery service	9-20
Battery capacity label	9-20
Battery recharging	9-20
Reset items	9-21
Tires and wheels.....	9-22
Tire care	9-22
Recommended cold tire inflation pressures	9-22
Check tire inflation pressure.....	9-23
Tire rotation	9-24
Wheel alignment and tire balance	9-24
Tire replacement	9-25
Wheel replacement	9-25
Tire traction.....	9-25
Tire maintenance.....	9-26
Tire sidewall labeling.....	9-26
Low aspect ratio tires.....	9-28
Fuses.....	9-29
Instrument panel fuse replacement.....	9-30
Motor compartment panel fuse replacement.....	9-30
Fuse/relay panel description	9-32
Light bulbs	9-41
Headlight, position light, turn signal light, daytime running light (DRL) replacement	9-42
Headlight aiming	9-44
Side repeater light replacement.....	9-47
Rear combination light replacement	9-47
High mounted stop light replacement	9-49
License plate light replacement	9-49
Interior light replacement.....	9-49
Appearance care	9-51
Exterior care.....	9-51
Interior care	9-56

Motor compartment

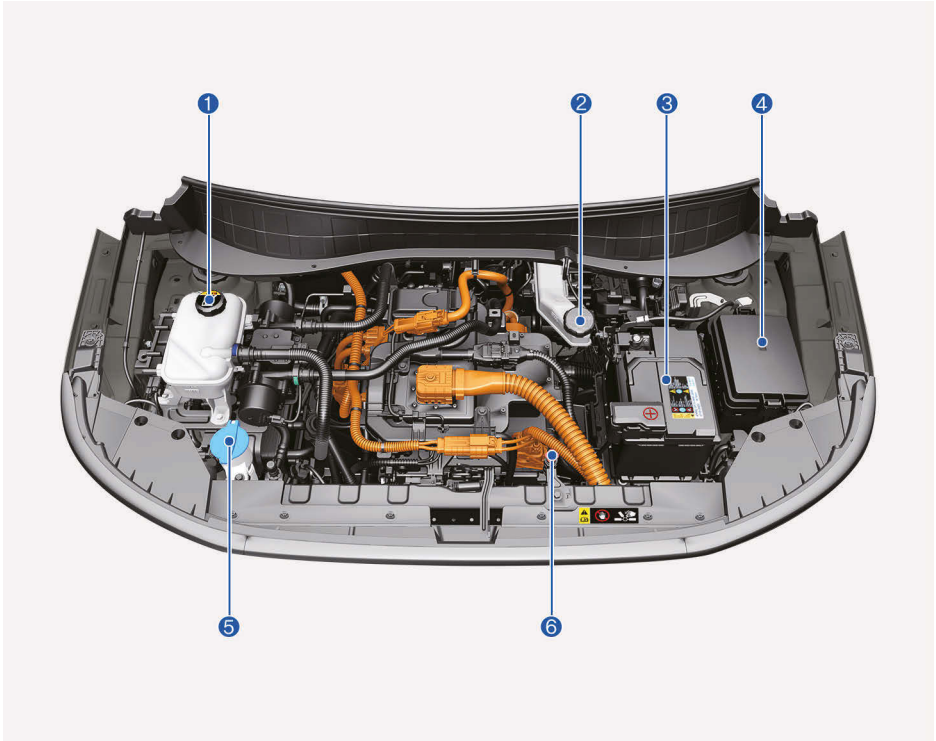

The actual motor compartment in the vehicle may differ from the illustration.

- (1) Coolant reservoir
- (2) Brake fluid reservoir
- (3) Battery (12 V)
- (4) Fuse box
- (5) Windshield washer fluid reservoir
- (6) Emergency cable

Maintenance services

You should exercise the utmost care to prevent damage to your vehicle and injury to yourself whenever performing any maintenance or inspection procedures.

We recommend you have your vehicle maintained and repaired by an authorized HYUNDAI dealer. An authorized HYUNDAI dealer meets HYUNDAI's high service quality standards and receives technical support from HYUNDAI in order to provide you with a high level of service satisfaction.

Owner's responsibility

Maintenance service and record retention are the owner's responsibility.

You should retain documents that show proper maintenance has been performed on your vehicle in accordance with the scheduled maintenance service charts shown on the following pages. You need this information to establish your compliance with the servicing and maintenance requirements of your vehicle warranties.

Detailed warranty information is provided in your Service Passport.

Repairs and adjustments required as a result of improper maintenance or a lack of required maintenance are not covered.

Owner maintenance precautions

Inadequate, incomplete or insufficient servicing may result in operational problems with your vehicle that could lead to vehicle damage, an accident, or personal injury. This chapter provides instructions only for the maintenance items that are easy to perform.

Your vehicle should not be modified in any way. Such modifications may adversely affect the performance, safety or durability of your vehicle and may, in addition, violate conditions of the limited warranties covering the vehicle.

NOTICE

Improper owner maintenance during the warranty period may affect warranty coverage. For more information, read the separate Service Passport provided with the vehicle. If you are unsure about any service or maintenance procedure, we recommend to have it done by an authorized HYUNDAI dealer.

Owner maintenance

WARNING

Performing maintenance work on a vehicle can be dangerous. If you lack sufficient knowledge and experience or the proper tools and equipment to do the work, we recommend that it is done by an authorized HYUNDAI dealer. ALWAYS follow these precautions for performing maintenance work:

- Park your vehicle on level ground. Shift the vehicle to P (Park), apply the parking brake, and press the Start/Stop button to the OFF position.
- Block the tires (front and back) to prevent the vehicle from moving. Remove loose clothing or jewelry that can become entangled in moving parts.
- Keep flames, sparks, or smoking materials away from the battery parts.

WARNING

Make sure to turn the Start/Stop button to the OFF position to shut down the vehicle before performing maintenance work on the vehicle.

The following lists are vehicle checks and inspections that should be performed by the owner or an authorized HYUNDAI dealer at the frequencies indicated to help ensure safe, dependable operation of your vehicle.

Any adverse conditions should be brought to the attention of your dealer as soon as possible.

These Owner Maintenance vehicle checks are generally not covered by warranties and you may be charged for labor, parts and lubricants used.

The electric control system in the vehicle may cause malfunction or other negative impact on the artificial heart and the artificial internal organs. Be sure to inquire the impact of the electric control system on the artificial organs from the medical product corporation.

Owner maintenance schedule

When you stop for charging:

- Check the coolant level in the coolant reservoir.
- Check the windshield washer fluid level.
- Check for low or under-inflated tires.

WARNING

Be careful when checking your coolant level if the motor compartment is hot. This may result in coolant being blown out of the opening and cause serious burns and other injuries.

While operating your vehicle:

- Check for vibrations in the steering wheel. Notice if there is any increased steering effort or looseness in the steering wheel, or change in its straight-ahead position.
- Notice if your vehicle constantly turns slightly or "pulls" to one side when traveling on smooth, level road.
- When stopping, listen and check for unusual sounds, pulling to one side, increased brake pedal travel or "hard-to-push" brake pedal.
- If any slipping or changes in the operation of your gear shift occurs, check the shift gear fluid level.
- Check the shift gear P (Park) function.
- Check the parking brake.
- Check for fluid leaks under your vehicle (water dripping from the air conditioning system during or after use is normal).

At least monthly:

- Check coolant level in the coolant reservoir.
- Check the operation of all exterior lights, including the stoplights, turn signals and hazard warning flashers.
- Check the inflation pressures of all tires including the spare for tires that are worn, show uneven wear, or are damaged.
- Check for loose wheel nuts.

At least twice a year: (for example, every Spring and Autumn)

- Check radiator, heater and air conditioning hoses for leaks or damage.
- Check windshield washer spray and wiper operation. Clean wiper blades with a clean cloth dampened with washer fluid.
- Check headlight alignment.
- Check the seat belts for wear and function.

At least once a year:

- Clean body and door drain holes.
- Lubricate door hinges and hood hinges.
- Lubricate door and hood locks and latches.
- Lubricate door rubber weather strips.
- Check the air conditioning system.
- Inspect and lubricate shift gear linkage and controls.
- Clean the battery (12 V) and terminals.
- Check the brake fluid level.

Scheduled maintenance services

Follow Normal Maintenance Schedule if the vehicle is usually operated where none of the following conditions apply. If any of the following conditions apply, you must follow the Maintenance Under Severe Usage Conditions.

- Repeated driving short distance of less than 8 km (5 mi.) in normal temperature or less than 16 km (10 mi.) in freezing temperature
- Driving on rough, dusty, muddy, unpaved, graveled or salt-spread roads
- Driving in areas using salt or other corrosive materials or in very cold weather
- Driving in heavy dust conditions
- Driving in heavy traffic area with the ambient temperature higher than 32 °C (90 °F) while consuming more than 50 % of electric energy.
- Driving on uphill, downhill, or mountain roads repeatedly
- Towing a trailer or using a camper, or driving with loads on the roof
- Driving as a patrol car, taxi, other commercial use of vehicle towing
- Frequently driving under high speed or rapid acceleration/deceleration
- Frequently driving in stop-and-go condition

If your vehicle is operated under the above conditions, you should inspect, replace or refill more frequently than the following Normal Maintenance Schedule. After the periods or distance shown in the chart, continue to follow the prescribed maintenance intervals.

Normal maintenance schedule

The following maintenance services must be performed to ensure good vehicle performance.

Keep receipts for all vehicle services to protect your warranty. Where both mileage and time are shown, the frequency of service is determined by whichever occurs first.

I: Inspect and if necessary, adjust, correct, clean or replace.

R: Replace or change.

Maintenance intervals	Number of months or driving distance, whichever comes first								
	Months	24	48	72	96	120	144	168	192
	Mi.×1,000	20	40	60	80	100	120	140	160
Maintenance item	Km×1,000	30	60	90	120	150	180	210	240
Cooling system		I	I	I	I	I	I	I	I
Coolant *1	At first, replace at 180,000 km (120,000 mi.) or 10 years; after that, replace every 30,000 km (20,000 mi.) or 24 months.								
Reduction gear fluid			I		I		I		I
12V auxiliary battery condition	For Europe	I	I	I	I	I	I	I	I
	Except Europe	Inspect 15,000 km (10,000 mi.) or 12 months							
All electrical system		I	I	I	I	I	I	I	I
Brake lines, hoses and connections		I	I	I	I	I	I	I	I
Brake pedal		I	I	I	I	I	I	I	I
Parking brake		I	I	I	I	I	I	I	I
Brake fluid		R	R	R	R	R	R	R	R
Brake discs and pads		I	I	I	I	I	I	I	I
Pan-European eCall system battery (if equipped)	Replace every 4 years								
UAE eCall system battery (if equipped)	Replace every 4 years								
Rotate Tires	Rotate tires every 30,000 km (20,000 mi.) or 24 months								

Maintenance intervals	Number of months or driving distance, whichever comes first								
	Months	24	48	72	96	120	144	168	192
	Mi. x1,000	20	40	60	80	100	120	140	160
	Km x1,000	30	60	90	120	150	180	210	240
Maintenance item									
Cabin air filter	For Europe	R	R	R	R	R	R	R	R
	Except Europe	Replace 15,000 km (10,000 mi.) or 12 months							
Steering gear rack, linkage and boots		I	I	I	I	I	I	I	I
Driveshaft and boots		I	I	I	I	I	I	I	I
Tire (pressure & tread wear)		I	I	I	I	I	I	I	I
Front suspension ball joints		I	I	I	I	I	I	I	I
Bolt and nuts on chassis and body		I	I	I	I	I	I	I	I
Air conditioner refrigerant		I	I	I	I	I	I	I	I
Air conditioner compressor		I	I	I	I	I	I	I	I

*1 When replacing or adding coolant, we recommend that you visit an authorized HYUNDAI dealer.

Maintenance under severe usage conditions

The following items must be serviced more frequently on cars mainly used under severe driving conditions.

Refer to the chart below for the appropriate maintenance intervals.

R: Replace

I: Inspect and if necessary, adjust, correct, clean or replace

Maintenance item	Maintenance operation	Maintenance intervals	Driving condition
Reduction gear fluid	R	Every 120,000 km (80,000 mi.)	B, D, G, H
Steering gear rack, linkage and boots	I	Inspect more frequently depending on the condition	C, D, E, F, G
Front suspension ball joints	I	Inspect more frequently depending on the condition	B, C, D, E, F
Disc brakes and pads, calipers and rotors	I	Inspect more frequently depending on the condition	B, C, D, E, F, G, H, I, J
Driveshaft and boots	I	Inspect more frequently depending on the condition	B, C, D, E, F, G, H, I
Cabin air filter	R	Replace more frequently depending on the condition	B,D,F

Severe driving conditions

- A. Repeatedly driving short distance of less than 8 km (5 mi.) in normal temperature or less than 16 km (10 mi.) in freezing temperature
- B. Driving on rough, dusty, muddy, unpaved, graveled or salt spread roads
- C. Driving in areas using salt or other corrosive materials or in very cold weather
- D. Driving in heavy dust condition
- E. Driving in heavy traffic area with the ambient temperature higher than 32 °C (90 °F) while consuming more than 50 % of electric energy.
- F. Driving on uphill, downhill, or mountain roads repeatedly
- G. Towing a trailer or using a camper, or driving with loads on the roof
- H. Driving as a patrol car, taxi, other commercial use or vehicle towing
- I. Frequently driving under high speed or rapid acceleration/deceleration
- J. Frequently driving in stop-and-go conditions

Explanation of scheduled maintenance items

Cooling system

Check cooling system components, such as radiator, coolant reservoir, hoses and connections for leakage and damage. Replace any damaged parts.

Coolant

The coolant should be changed at the intervals specified in the maintenance schedule.

Reduction gear fluid

The reduction gear fluid should be inspected according to the intervals specified in the maintenance schedule.

Brake hoses and lines

Visually check for proper installation, chafing, cracks, deterioration and any leakage. Replace any deteriorated or damaged parts immediately.

Brake fluid

Check the brake fluid level in the brake fluid reservoir. The level should be between the MIN and the MAX marks on the side of the reservoir. Use only hydraulic brake fluid conforming to DOT 4 specification.

Brake discs, pads, calipers and rotors

Check the pads, the disc, and the rotor for any excessive wear-out. Inspect calipers for any fluid leakage.

For more information on checking the pads or lining wear limit, visit <http://service.hyundai-motor.com>

Suspension mounting bolts

Check the suspension connections for looseness or damage. Retighten to the specified torque.

Steering gear box, linkage & boots/lower arm ball joint

With the vehicle stopped and the vehicle off, check for excessive free-play in the steering wheel. Check the linkage for bends or damage. Check the dust boots and ball joints for deterioration, cracks, or damage.

Replace any damaged parts.

Drive shafts and boots

Check the drive shafts, boots and clamps for cracks, deterioration, or damage. Replace any damaged parts and, if necessary, repack the grease.

Air conditioning refrigerant

Check the air conditioning lines and connections for leakage and damage.

Coolant

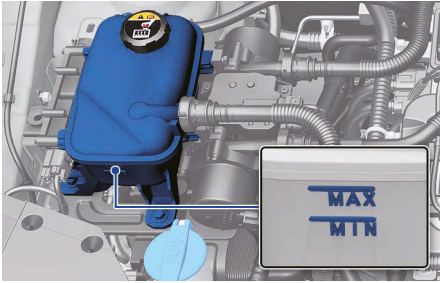

Check the condition and connections of all cooling system hoses and heater hoses. Replace any swollen or deteriorated hoses.

The coolant level should be filled between the MAX and MIN marks on the side of the coolant reservoir when the parts in the motor compartment is cool.

If the coolant level is low, add enough distilled (deionized) water mixed with antifreeze to bring the level to the MAX mark. If frequent additions are required, we recommend that your vehicle be inspected by an authorized HYUNDAI dealer.

WARNING



Keep hands, clothing, and tools away from the rotating fan blades of the cooling fan. The electric motor for the cooling fan may continue to operate or start up when the vehicle is off and can cause serious injury.

The electric motor for the cooling fan is controlled by vehicle coolant temperature, refrigerant pressure, and vehicle speed. As the vehicle coolant temperature decreases, the electric motor automatically shuts off. This is a normal condition.

WARNING



- Check the coolant level when the motor compartment is cooled. Coolant level is influenced by temperature, and if the coolant reservoir cap is removed when coolant temperature is high, hot coolant and steam may blow out under pressure causing serious injury.
- Make sure the coolant cap is properly closed after refilling coolant. Otherwise the motor could be overheated while driving.

WARNING

Make sure the coolant cap is properly closed after refilling coolant. Otherwise, the motor could be overheated while driving.

1. Check if the coolant cap label is straight in front.



2. Make sure that the tiny protrusions inside the coolant cap is securely interlocked.

Recommended coolant

- When adding coolant, use only deionized water, distilled water or soft water for your vehicle and never mix hard water in the coolant filled at the factory.
- An incorrect coolant mixture can result in severe malfunction or motor damage.
- Do not use alcohol or methanol coolant or mix them with the specified coolant.
- Do not use a solution that contains more than 60 % antifreeze or less than 35 % antifreeze, which would reduce the effectiveness of the solution.

For mixing percentage, refer to the following table:

Ambient temperature	Mixture percentage (volume)	
	Antifreeze	Water
-15 °C (5 °F)	35	65
-25 °C (-13 °F)	40	60
-35 °C (-31 °F)	50	50
-45 °C (-49 °F)	60	40

i Information

If in doubt about the mix ratio, a 50 % water and 50 % antifreeze mix is the easiest to mix together because it is the same quantity of each.

Changing coolant

We recommend that the coolant be changed by a authorized HYUNDAI dealer according to the maintenance schedule.

! WARNING

Do not use coolant or antifreeze in the washer fluid reservoir.

Coolant can severely obscure visibility when sprayed on the windshield and may cause loss of vehicle control resulting in an accident.

Coolant may also cause damage to paint and body trim.

NOTICE

To prevent damage to motor parts, put a thick towel around the coolant cap before refilling the coolant to prevent the coolant from overflowing into motor parts.

Brake fluid

Checking the brake fluid level

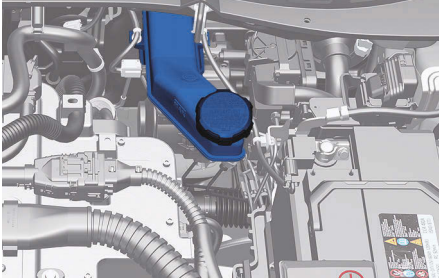

Check the fluid level in the reservoir periodically. The fluid level should be between MAX and MIN marks on the side of the reservoir.

Before removing the reservoir cap and adding brake fluid, clean the area around the reservoir cap thoroughly to prevent brake fluid contamination.

If the level is low, add the specified brake fluid to the MAX level. The level will fall with accumulated kilometers. This is a normal condition associated with the wear of the brake linings. If the fluid level is excessively low, we recommend that the brake system be checked by an authorized HYUNDAI dealer.

WARNING

If the brake system requires frequent additions of fluid this could indicate a leak in the brake system. We recommend that the vehicle be inspected by an authorized HYUNDAI dealer.

WARNING

Do not let brake fluid enter into your eyes. If brake fluid gets in your eyes, flush your eyes with clean water for at least 15 minutes and get immediate medical attention.

NOTICE

- Do not allow brake fluid to contact the vehicle's body paint, as it will result in paint damage.
- NEVER use brake fluid which has been exposed to open air for an extended time, as its quality cannot be guaranteed. It should be disposed of properly.
- Do not use the wrong type of brake fluid. A few drops of mineral based oil in your brake system can damage brake system parts.

i Information

Use only the specified brake fluid (refer to the "Recommended lubricants and capacities" section in chapter 2).

Reduction gear fluid

There is no reduction gear fluid level gauge in the vehicle. Check the reduction gear fluid every 60,000 km (40,000 mi) regularly. If the vehicle is driven under severe condition, we recommend that you check the maintenance under severe usage condition and consult an authorized HYUNDAI dealer.

Washer fluid

Checking the washer fluid level

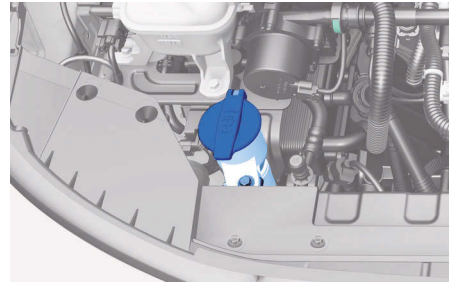

Check the fluid level in the washer fluid reservoir and add fluid if necessary. Plain water may be used if washer fluid is not available. However, use washer solvent with antifreeze characteristics in cold climates to prevent freezing.

WARNING

To prevent serious injury or death, take the following safety precautions when using washer fluid:

- Do not use coolant or antifreeze in the washer fluid reservoir. Coolant can severely obscure visibility when sprayed on the windshield and may cause loss of vehicle control resulting in an accident or damage to paint and body trim.
- Do not allow sparks or flame to contact the washer fluid or the washer fluid reservoir. Washer fluid may contain alcohol and can be flammable.
- Do not drink washer fluid and avoid contact with skin. Washer fluid is harmful to humans and animals.
- Keep washer fluid away from children and animals.

Cabin air filter

Filter inspection

The cabin air filter should be replaced according to the Maintenance Schedule. If the vehicle is operated in severely air-polluted cities or on dusty rough roads for a long period, it should be inspected more frequently and replaced sooner. Replace the cabin air filter by following the procedure below and be careful to avoid damaging other components.

Filter replacement

1. Open the glove box (2) and remove the support rod (1).



2. Press and hold the lock on the right side of the cover.



3. Pull out the cover.
4. Replace the cabin air filter.
5. Reassemble in the reverse order of disassembly.

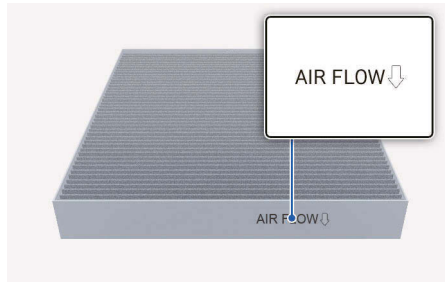

Install a new cabin air filter in the correct direction with the arrow symbol (↓) facing downwards, to prevent noise and reduce effectiveness.

Otherwise it may cause interior damage in the motor compartment, noise trouble, or entrance of foreign substances.

Wiper blades

Blade inspection

Contamination of the windshield or wiper blades with foreign substances may reduce the effectiveness of the windshield wipers.

Common sources of contamination are insects, tree sap, and hot wax treatments used by some commercial car washes. If the blades are not wiping properly, clean both the window and the blades with glass cleaner or mild detergent, and rinse thoroughly with clean water. Replace blades as needed.

NOTICE

To prevent damage to the wiper blades, arms, or other components, do not:

- Use gasoline, kerosene, paint thinner, or other solvents on or near them.
- Attempt to move the wipers manually.

Blade replacement

When the wipers no longer clean adequately, the blades may be worn or cracked. Replace the wipers with new ones.

NOTICE

To prevent damage:

- Never use non-specified wiper blades.
- Lift the wiper arms when in the top wiping position.
- Always return the wiper arms to the windshield before driving.

Front windshield wiper blade replacement

This vehicle has a "hidden" wiper design that cannot be lifted when in their bottom resting position.

1. Within 20 seconds of turning off the vehicle, push and hold the wiper lever down to the MIST (or 1x) position for about 2 seconds until the wipers move to the top wipe position.

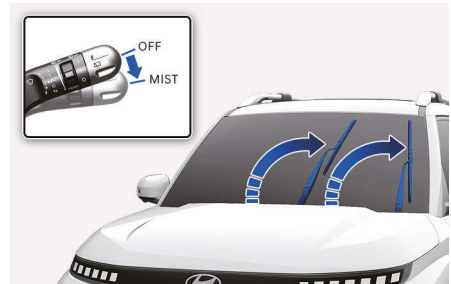

2. Lift the wipers off the windshield.
3. Lift up the wiper blade clip (1). Then pull down the wiper blade (2). Remove the wiper blade from the wiper arm (3).

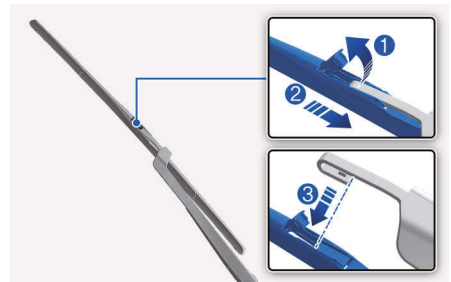

4. Install a new wiper blade assembly in the reverse order of removal.

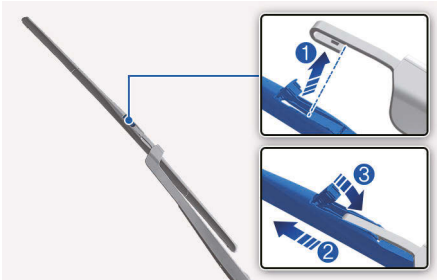

5. Gently put down the wiper back onto the windshield.
6. With the Start/Stop button in the ON position, turn the wiper switch to any ON position to return the wipers to the bottom resting position.

NOTICE

- Avoid the wipers from touching the windshield when the wiper blade is disassembled to prevent windshield damage.
- The wiper may not operate for about 10 seconds if the wiper is operated without washer fluid or the blades are frozen to prevent damage to the motor.

Rear window wiper blade replacement

1. Raise the wiper arm and then rotate the wiper blade assembly (1).
2. Pull out the wiper blade assembly (2).

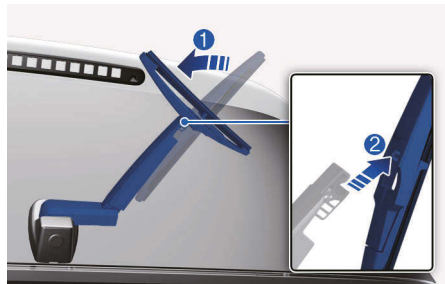

3. Install the new blade assembly by inserting the center part into the slot in the wiper arm until it clicks into place (3).

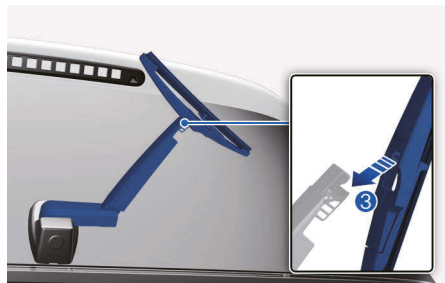

4. If the replacement is complete, put down the wiper arm onto the rear windshield, and turn the vehicle ON and operate the wipers to check the blade is installed correctly.

Battery (12 V)

WARNING

To prevent **SERIOUS INJURY** or **DEATH** to you or bystanders, always follow these precautions when working near or handling the battery:

Always read and follow instructions carefully when handling a battery.



Wear eye protection designed to protect the eyes from acid splashes.



Keep all flames, sparks, or smoking materials away from the battery.



Hydrogen is always present in battery cells, is highly combustible, and may explode if ignited.



Keep batteries out of reach of children.



Batteries contain sulfuric acid which is highly corrosive. Do not allow acid to contact your eyes, skin or clothing.

If acid gets into your eyes, flush your eyes with clean water for at least 15 minutes and get immediate medical attention. If acid gets on your skin, thoroughly wash the area. If you feel pain or a burning sensation, get medical attention immediately.



- When lifting a plastic-cased battery, excessive pressure on the case may cause battery acid to leak. Lift with a battery carrier or with your hands on opposite corners.
- Do not attempt to jump start your vehicle if your battery is frozen.
- NEVER attempt to recharge the battery when the vehicle's battery cables are connected to the battery.
- The electrical ignition switch works with high voltage. NEVER touch these components with the READY indicator ON or when the Start/Stop button is in the ON position.

NOTICE

Always follow these instructions when handling your vehicle's battery to prevent damage to your battery:

- When you do not use the vehicle for a long time in a low temperature area, disconnect the battery and keep it indoors.
- Always charge the battery fully to prevent battery case damage in low temperature areas.

- Prevent liquid from wetting the battery terminals. The performance of the battery may be degraded, and may cause injury. Be cautious when loading liquid in the cargo area.
- Do not tilt the battery.
- If you connect unauthorized electronic devices to the battery, the battery may be discharged. Never use unauthorized devices.

For best battery service

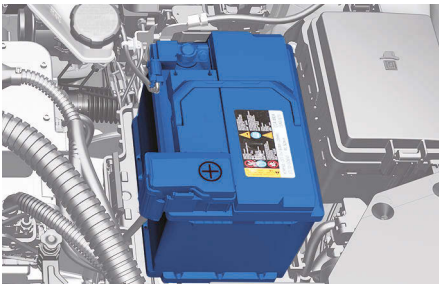

- Keep the battery securely mounted.
- Keep the battery top clean and dry.
- Keep the terminals and connections clean, tight, and coated with petroleum jelly or terminal grease.
- Rinse any spilled electrolyte from the battery immediately with a solution of water and baking soda.
- If the vehicle is not going to be used for an extended time, disconnect the battery cables.

Battery capacity label



1. eCM60L-DIN: The HYUNDAI model name of battery
2. 12V: The nominal voltage
3. 60Ah (20HR): The nominal capacity (in Ampere hours)
4. RC 92min: The nominal reserve capacity (in min.)
5. CCA 480A (SAE/EN): The cold-test current in amperes

i Information

The actual battery label in the vehicle may differ from the illustration.

Battery recharging

By battery charger

Your vehicle has a maintenance-free, calcium-based battery.

- If the battery becomes discharged over a short time (because, for example, the headlights or interior lights were left on while the vehicle was not in use), recharge it by slow charging (trickle) for 10 hours.
- If the battery gradually discharges because of high electrical load while the vehicle is being used, recharge it at 20-30A for two hours.

WARNING

Always follow these instructions when recharging your vehicle's battery to avoid the risk of **SERIOUS INJURY** or **DEATH** from explosions or acid burns:

- Before performing maintenance or recharging the battery, turn off all accessories and stop the vehicle.
- Keep all flames, sparks, or smoking materials away from the battery.
- Always work outdoors or in an area with plenty of ventilation.
- Wear eye protection when checking the battery during charging.
- The battery must be removed from the vehicle and placed in a well ventilated area.
- Watch the battery during charging, and stop or reduce the charging rate if the battery cells begin boiling violently.
- The negative battery cable must be removed first and installed last when the battery is disconnected. Disconnect the battery charger in the following order:
 1. Turn off the battery charger main switch.
 2. Unhook the negative clamp from the negative battery terminal.
 3. Unhook the positive clamp from the positive battery terminal.
- We recommend that you use batteries for replacement from an authorized HYUNDAI dealer.

By jump starting

After a jump start from a good battery, drive the vehicle for 20-30 minutes before it is shutoff. The vehicle may not restart if you shut it off before the battery had a chance to adequately recharge. See "Jump starting (12 V battery)" in chapter 8 for more information on jump starting procedures.

Information



An inappropriately disposed battery can be harmful to the environment and human health. Dispose of the battery according to your local law(s) or regulation.

Reset items

The following items may need to be reset after the battery has been discharged or the battery has been disconnected.

- Current Trip/After Charging/Since Last Reset (refer to chapter 4)
- Power window (refer to chapter 5)
- Sunroof (refer to chapter 5)
- Climate control system (refer to chapter 5)
- Tailgate (refer to chapter 5)
- Clock (refer to Infotainment system manual)
- Infotainment system (refer to Infotainment system manual)

Tires and wheels

WARNING

Tire failure may cause loss of vehicle control resulting in an accident. To reduce risk of **SERIOUS INJURY** or **DEATH**, take the following precautions:

- Inspect your tires monthly for proper inflation as well as wear and damage.
- The recommended cold tire pressure for your vehicle can be found in this manual and on the tire label located on the driver's side center pillar. Always use a tire pressure gauge to measure tire pressure. Tires with too much or too little pressure wear unevenly causing poor handling.
- Check the pressure of the spare every time you check the pressure of the other tires on your vehicle.
- Replace tires that are worn, show uneven wear, or are damaged. Worn tires can cause loss of braking effectiveness, steering control, or traction.
- ALWAYS replace tires with the same size, type, construction and tread pattern as each tire that was originally supplied with this vehicle. Using tires and wheels other than the recommended sizes could cause unusual handling characteristics, poor vehicle control, or negatively affect your vehicle's Anti-Lock Brake System (ABS) resulting in a serious accident.

Tire care

For proper maintenance, safety, and maximum electric energy economy, you must always maintain recommended tire inflation pressures and stay within the load limits and weight distribution recommended for your vehicle.



All specifications (sizes and pressures) can be found on a label attached to the driver's side center pillar.

Recommended cold tire inflation pressures

All tire pressures (including the spare) should be checked when the tires are cold. "Cold tires" means the vehicle has not been driven for at least 3 hours or driven less than 1.6 km (1 mi.).

Warm tires normally exceed recommended cold tire pressures by 28 to 41 kPa (4 to 6 psi). Do not release air from warm tires to adjust the pressure or the tires will be under-inflated. For recommended inflation pressure, refer to the "Tires and wheels" section in chapter 2.

 **WARNING**

Recommended pressures must be maintained for the best ride, vehicle handling, and minimum tire wear.

Over-inflation or under-inflation can reduce tire life, adversely affect vehicle handling, and lead to sudden tire failure that could result in loss of vehicle control resulting in an accident.

Severe under-inflation can lead to severe heat build-up, causing blowouts, tread separation and other tire failures that can result in the loss of vehicle control resulting in an accident. This risk is much higher on hot days and when driving for long periods at high speeds.

 **CAUTION**

- Under-inflation results in excessive wear, poor handling and reduced electric energy economy. Wheel deformation is also possible. Keep your tire pressures at the proper levels. If a tire frequently needs refilling, we recommend it be checked by an authorized HYUNDAI dealer.
 - Over-inflation produces a harsh ride, excessive wear at the center of the tire tread, and a greater possibility of damage from road hazards.
-

Check tire inflation pressure

Check your tires, including the spare tire, once a month or more.

How to check

Use a good quality tire pressure gauge to check tire pressure. You can not tell if your tires are properly inflated simply by looking at them. Radial tires may look properly inflated when they are under-inflated.

Remove the valve cap from the tire valve stem. Press the tire gauge firmly onto the valve to get a pressure measurement. If the cold tire inflation pressure matches the recommended pressure on the tire and loading information label, no further adjustment is necessary. If the pressure is low, add air until you reach the recommended pressure. Make sure to put the valve caps back on the valve stems. Without the valve cap, dirt or moisture could get into the valve core and cause air leakage. If a valve cap is missing, install a new one as soon as possible.

If you overfill the tire, release air by pushing on the metal stem in the center of the tire valve. Recheck the tire pressure with the tire gauge. Be sure to put the valve caps back on the valve stems. Without the valve cap, dirt or moisture could get into the valve core and cause air leakage. If a valve cap is missing, install a new one as soon as possible.

Tire rotation

To equalize tread wear, HYUNDAI recommends that the tires be rotated every 12,000 km (7,500 mi.) or sooner if irregular wear develops.

During rotation, check the tires for correct balance.

When rotating tires, check for uneven wear and damage. Abnormal wear is usually caused by incorrect tire pressure, improper wheel alignment, out-of-balance wheels, severe braking or severe cornering. Look for bumps or bulges in the tread or side of the tire. Replace the tire if you find any of these conditions. Replace the tire if fabric or cord is visible. After rotation, be sure to bring the front and rear tire pressures to specification and check nut torque (proper torque is 11-13 kgf-m [79-94 lbf-ft]).

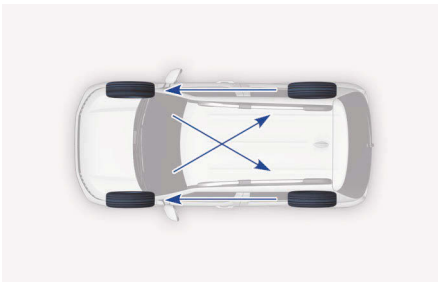

Disc brake pads should be inspected for wear whenever tires are rotated.

i Information

The outside and inside of the unsymmetrical tire is distinguishable. When installing an unsymmetrical tire, be sure to install the side marked "outside" face the outside. If the side marked "inside" is installed on the outside, it will have a negative effect on vehicle performance.

WARNING

- Do not use the compact spare tire for tire rotation.
- Do not mix bias ply and radial ply tires under any circumstances. This may cause unusual handling characteristics that may cause loss of vehicle control resulting in an accident.

Wheel alignment and tire balance

The wheels on your vehicle were aligned and balanced carefully at the factory to give you the longest tire life and best overall performance.

In most cases, you will not need to have your wheels aligned again. However, if you notice unusual tire wear or your vehicle pulling one way or the other, the alignment may need to be reset.

If you notice your vehicle vibrating when driving on a smooth road, your wheels may need to be rebalanced.

NOTICE

Incorrect wheel weights can damage your vehicle's aluminum wheels. Use only approved wheel weights.

Tire replacement

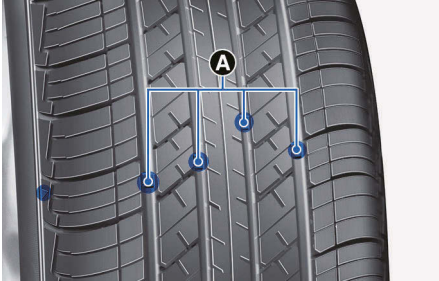

[A] Tread wear indicator

If the tire is worn evenly, a tread wear indicator will appear as a solid band across the tread. This shows there is less than 1.6 mm (1/16 in.) of tread left on the tire. Replace the tire when this happens.

Do not wait for the band to appear across the entire tread before replacing the tire.

WARNING

To reduce the risk of DEATH or SERIOUS INJURY:

- Replace tires that are worn, show uneven wear, or are damaged. Worn tires can cause loss of braking effectiveness, steering control, and traction.
- Always replace tires with the same size as each tire that was originally supplied with this vehicle. Using tires and wheels other than the recommended sizes could cause unusual handling characteristics, poor vehicle control, or negatively affect your vehicle's Anti-Lock Brake System (ABS) resulting in a serious accident.
- When replacing tires (or wheels), it is recommended to replace the two front or two rear tires (or wheels) as a pair. Replacing just one tire can seriously affect your vehicle's handling.

- Tires degrade over time, even when they are not being used. Regardless of the remaining tread, HYUNDAI recommends that tires be replaced after 6 years of normal service.
- Heat caused by hot climates or frequent high loading conditions can accelerate the aging process. Failure to follow this warning may cause sudden tire failure, which could lead to a loss of vehicle control resulting in an accident.

WARNING

The original tire should be repaired or replaced as soon as possible to avoid failure of the spare and loss of vehicle control resulting in an accident. The compact spare tire is for emergency use only. Do not operate your vehicle over 80 km/h (50 mph) when using the compact spare tire.

Wheel replacement

When replacing the metal wheels for any reason, make sure the new wheels are equivalent to the original factory units in diameter, rim width and offset.

Tire traction

Tire traction can be reduced if you drive on worn tires, tires that are improperly inflated or on slippery road surfaces. Tires should be replaced when tread wear indicators appear. To reduce the possibility of losing control, slow down whenever there is rain, snow or ice on the road.

Tire maintenance

In addition to proper inflation, correct wheel alignment helps to decrease tire wear. If you find a tire is worn unevenly, have your dealer check the wheel alignment.

When you have new tires installed, make sure they are balanced. This will increase vehicle ride comfort and tire life. Additionally, a tire should always be rebalanced if it is removed from the wheel.

Tire sidewall labeling

This information identifies and describes the fundamental characteristics of the tire and also provides the tire identification number (TIN) for safety standard certification. The TIN can be used to identify the tire in case of a recall.

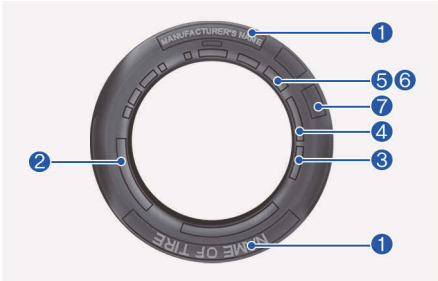

1. Manufacturer or brand name

Manufacturer or brand name is shown.

2. Tire size designation

A tire's sidewall is marked with a tire size designation. You will need this information when selecting replacement tires for your car. The following explains what the letters and numbers in the tire size designation mean.

Example tire size designation:

(These numbers are provided as an example only; your tire size designator could vary depending on your vehicle.)

235/45 R19 99V

235: Tire width in millimeters.

45: Aspect ratio. The tire's section height as a percentage of its width.

R: Tire construction code (Radial).

19: Rim diameter in inches.

99: Load Index, a numerical code associated with the maximum load the tire can carry.

V: Speed Rating Symbol. See the speed rating chart in this section for additional information.

Wheel size designation

Wheels are also marked with important information that you need if you ever have to replace one. The following explains what the letters and numbers in the wheel size designation mean.

Example wheel size designation:

7.5J X 19

7.5: Rim width in inches.

J: Rim contour designation.

19: Rim diameter in inches.

Tire speed ratings

The chart below lists many of the different speed ratings currently being used for passenger vehicle tires. The speed rating is part of the tire size designation on the sidewall of the tire. This symbol corresponds to that tire's designed maximum safe operating speed.

Speed Rating Symbol	Maximum Speed
S	180 km/h (112 mph)
T	190 km/h (118 mph)

Speed Rating Symbol	Maximum Speed
H	210 km/h (130 mph)
V	240 km/h (149 mph)
W	270 km/h (168 mph)
Y	300 km/h (186 mph)

3. Checking tire life (TIN: Tire Identification Number)

Any tires that are over six years old, based on the manufacturing date, (including the spare tire) should be replaced by new ones. You can find the manufacturing date on the tire sidewall (possibly on the inside of the wheel), displaying the DOT Code. The DOT Code is a series of numbers on a tire consisting of numbers and English letters. The manufacturing date is designated by the last four digits (characters) of the DOT code.

DOT: XXX XXXXXX OOOO

The front part of the DOT shows a plant code number, tire size and tread pattern and the last four numbers indicate week and year manufactured.

For example:

DOT XXX XXXXXX 5024 represents that the tire was produced in the 50th week of 2024.

4. Tire ply composition and material

The number of layers or plies of rubber-coated fabric in the tire. Tire manufacturers also must indicate the materials in the tire, which include steel, nylon, polyester, and others. The letter "R" means radial ply construction; the letter "D" means diagonal or bias ply construction; and the letter "B" means belted-bias ply construction.

5. Maximum permissible inflation pressure

This number is the greatest amount of air pressure that should be put in the tire. Do not exceed the maximum permissible inflation pressure.

6. Maximum load rating

This number indicates the maximum load in kilograms and pounds that can be carried by the tire. When replacing the tires on the vehicle, always use a tire that has the same load rating as the factory installed tire.

7. Uniform tire quality grading

Quality grades can be found where applicable on the tire sidewall between tread shoulder and maximum section width.

For example:

TREADWEAR 200

TRACTION AA

TEMPERATURE A

Tread wear

The tread wear grade is a comparative rating based on the wear rate of the tire when tested under controlled conditions on a specified government test course. For example, a tire graded 150 would wear one-and-a-half times (1½) as well on the government course as a tire graded 100.

The relative performance of tires depends upon the actual conditions of their use, however, and may depart significantly from the norm due to variations in driving habits, service practices and differences in road characteristics and climate.

These grades are molded on the sidewalls of passenger vehicle tires. The tires available as standard or optional equipment on your vehicle may vary with respect to grade.

Traction - AA, A, B & C

The traction grades, from highest to lowest, are AA, A, B and C. Those grades represent the tire's ability to stop on wet pavement as measured under controlled conditions on specified government test surfaces of asphalt and concrete. A tire marked C may have poor traction performance.

WARNING

The traction grade assigned to this tire is based on straight ahead braking traction tests, and does not include acceleration, cornering, hydroplaning, or peak traction characteristics.

Temperature - A, B & C

The temperature grades are A (the highest), B and C representing the tire's resistance to the generation of heat and its ability to dissipate heat when tested under controlled conditions on a specified indoor laboratory test wheel. Sustained high temperature can cause the material of the tire to degenerate and reduce tire life, and excessive temperature can lead to sudden tire failure. Grades B and A represent higher levels of performance on the laboratory test wheel than the minimum required by law.

WARNING

The temperature grade for this tire is established for a tire that is properly inflated and not overloaded. Excessive speed, under-inflation, over-inflation, or excessive loading, either separately or in combination, can cause heat build-up and possible sudden tire failure. This may cause loss of vehicle control resulting in an accident.

Low aspect ratio tires

 If equipped

The aspect ratio is lower than 50 on low aspect ratio tires.

Because low aspect ratio tires are optimized for handling and braking, their sidewall is a little stiffer than a standard tire. Also low aspect ratio tires tend to be wider and consequently have a greater contact patch with the road surface. In some instances they may generate more road noise compared with standard tires.

CAUTION

The side wall of a low aspect ratio tire is shorter than the normal one. Thus, the low-aspect wheel and tire are easily damaged. Follow the below instructions.

- When driving on a rough road or driving off a road, be careful not to damage the tires and wheels. After driving, inspect the tires and wheels.
 - When passing over a pothole, speed bump, manhole, or curb stone, drive the vehicle slowly so as not to damage the tires and wheels.
 - When there is an impact on a tire, inspect the tire condition. We recommend that you contact an authorized HYUNDAI dealer.
 - Inspect the tire condition and pressure every 3,000 km (1,800 mi.) to prevent tire damage.
 - It is difficult to recognize a tire damage only with your eyes. When there is a slight hint of a tire damage, check and replace the tire to prevent the damage caused by air leakage.
 - When a tire is damaged while driving on a rough road, off a road, or over obstacles, such as a pothole, manhole, or curb stone, your warranty does not cover the damage.
 - The tire information is specified on the tire side wall.
-

Fuses

Blade type



Cartridge type

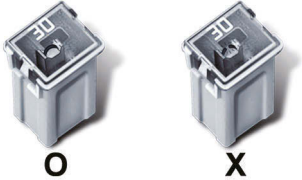

Multi type

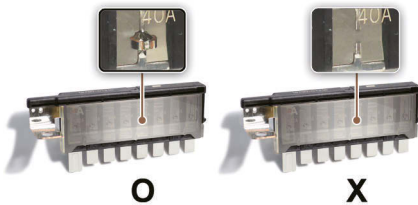

A vehicle's electrical system is protected from electrical overload damage by fuses.

This vehicle has 2 (or 3) fuse panels, one located in the driver's side panel bolster, the other in the motor compartment.

If any of your vehicle's lights, accessories, or controls do not work, check the appropriate circuit fuse. If a fuse has blown, the element inside the fuse is melted or broken.

If the electrical system does not work, first check the driver's side fuse panel. Before replacing a blown fuse, turn off the vehicle and all switches, and then disconnect the negative battery cable. Always replace a blown fuse with one of the same rating.

If the replacement fuse blows, this indicates an electrical problem. Avoid using the system involved and we recommend that you contact an authorized HYUNDAI dealer.

WARNING

Never replace a fuse with anything but another fuse of the same rating.

- A higher capacity fuse may cause damage and possibly cause a fire.
- Do not install a wire or aluminum foil instead of the proper fuse - even as a temporary repair. It may cause extensive wiring damage and possibly a fire.

NOTICE

Do not use a screwdriver or any other metal object to remove fuses because it may cause a short circuit and damage the system.

Instrument panel fuse replacement

1. Turn off the vehicle.
2. Turn off all other switches.
3. Open the fuse panel cover.



4. Pull the suspected fuse straight out. Use the removal tool provided in the motor compartment fuses panel cover.

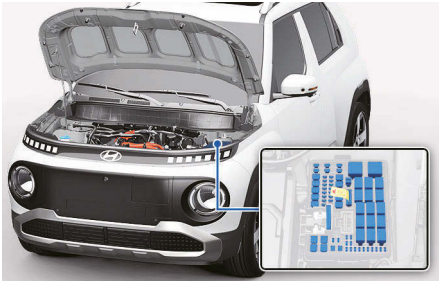

5. Check the removed fuse and replace it if it is blown. Spare fuses are provided in the instrument panel fuse panels (or in the motor compartment fuse panel).
6. Push in a new fuse of the same rating, and make sure it fits tightly in the clips. If it is not tight, we recommend that you contact an authorized HYUNDAI dealer.

In an emergency, if you do not have a spare fuse, use a fuse of the same rating from a circuit you may not need for operating the vehicle.

If the headlights or other electrical components do not work and the fuses are undamaged, check the fuse panel in the motor compartment.

Motor compartment panel fuse replacement

Blade fuse / Cartridge fuse

Blade type



Cartridge type



1. Turn off the vehicle.
2. Turn off all other switches.
3. Remove the fuse panel cover by pressing the tap and pulling up.
4. Refer to the label on the inside of the fuse panel cover to locate the suspected fuse location.

5. Pull the suspected fuse straight out.
Use the removal tool provided in the motor compartment fuses panel cover.
6. Check the removed fuse and replace it if it is blown. To remove or insert the fuse, use the fuse puller in the motor compartment fuse panel.
7. Push in a new fuse of the same rating, and make sure it fits tightly in the clips. If it is not tight, we recommend that your vehicle be inspected by an authorized HYUNDAI dealer.

NOTICE





Always securely install the fuse panel cover. Water may contact the fuse and cause an electrical failure.





Multi fuse









If the multi fuse or midi fuse is blown, contact an authorized HYUNDAI dealer.

Instrument panel fuse panel

Fuse name	Symbol	Fuse rating	Circuit protected
DOOR LOCK		20 A	Door Lock Relay, Door Unlock Relay
MODULE6	6 MODULE	10 A	IBU, HAZARD_SW, ICC_UNIT, RAIN_SNSR, VESS_UNIT
BRAKE SWITCH	BRAKE SWITCH	7.5 A	IBU, Stop Lamp Switch
IBU2	2 IBU	15 A	IBU
AIRBAG2	2 	10 A	SRS Control Module
HEATED MIRROR		10 A	Driver/Passenger Power Outside Mirror, A/C Control Module
START		7.5 A	IBU, VCU
MEMORY	MEMORY	10 A	FATC, ADAS PARK, CLUSTER, MLM, O/S MIRR FOLD/UNFOLD RLY
MULTIMEDIA	MULTI MEDIA	20 A	AVN, DISPLAY AUDIO
WIPER FRT2	2 	25 A	FRT_WIPER_MTR, ER J/B (Wiper LOW Relay)
MODULE5	5 MODULE	7.5 A	IBU, IAU
A/C2	2 A/C	7.5 A	A/C Control Module
E-CALL	E-CALL	7.5 A	E-CALL

Fuse name	Symbol	Fuse rating	Circuit protected
IAU	IAU	7.5 A	IAU
WASHER		15 A	Multifunction Switch
WIPERRR		10 A	Rear Wiper Motor
MODULE7	⁷ MODULE	10 A	A/C Control Module
MODULE2	² MODULE	7.5 A	Stop Lamp Switch
IEB3	³ IEB	7.5 A	IEB
IBU1	¹ IBU	7.5 A	IBU
EPCU2	² EPCU	10 A	VCU
CLUSTER	CLUSTER	7.5 A	Cluster Unit
MDPS 2	² 	7.5 A	MDPS Unit
MOUDLE4	⁴ MODULE	7.5 A	IBU, IAU
AIRBAG IND	^{IND} 	7.5 A	A/C Control Module
AIRBAG 1	¹ 	10 A	SRS Control Module
MODULE3	³ MODULE	10 A	FRT RADAR, ADAS PARK, IBU, RR CORNER RADAR, MFC UNIT

Fuse name	Symbol	Fuse rating	Circuit protected
E-SHIFTER3	³ E-SHIFTER	10 A	SCU, SBW_LEVER
SAFETY P/WINDOW RH	SAFETY RH 	25 A	[LHD] SAFETY_ECU_PASS [RHD] SAFETY_ECU_DRV
SAFETY P/WINDOW LH	SAFETY LH 	25 A	[LHD] SAFETY_ECU_DRV [RHD] SAFETY_ECU_PASS
S/HEATER	FRT 	20 A	Seat Heater Control Module
SUNROOF		15 A	Sunroof Glass Motor
P/WINDOW RH	RH 	25 A	[LHD/RHD]P_WDW_MAIN_SW [RHD]P_WDW_SW_PASS
P/WINDOW LH	LH 	25 A	[LHD/RHD]P_WDW_MAIN_SW [LHD]P_WDW_SW_PASS
MODULE 1	1 MODULE	10 A	O_S_MIRR_SW, USB CHARGER, ADAS PARK, IBU, E-CALL UNIT, AVN, KEYBOARD, IAU
POWER OUTLET 2	² POWER OUTLET	20 A	Power Outlet

Motor compartment fuse panel (Motor compartment junction block)



Inside the fuse panel cover, you can find the panel label describing fuse names and ratings.

i Information

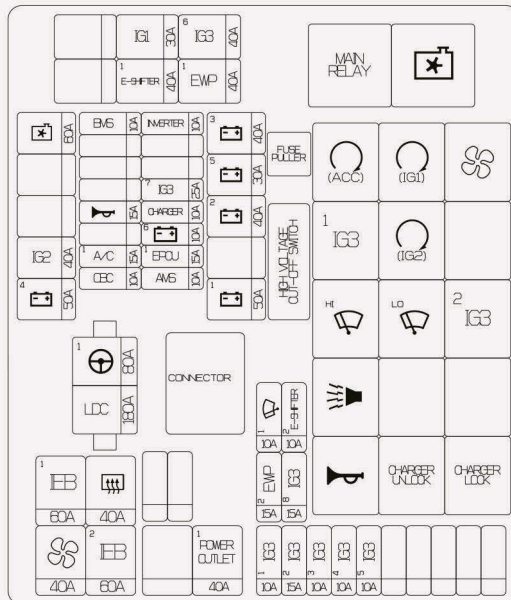

Not all fuse panel descriptions in this manual may be applicable to your vehicle. When you inspect the fuse panel on your vehicle, refer to the fuse panel label.





USE THE DESIGNATED FUSE AND RELAY ONLY
 USE SOLO LOS FUSIBLES Y RELEVADORES ESPECIFICADOS







91956-GX020

Motor compartment fuse panel (Motor compartment junction block)

Type	Fuse name	Symbol	Fuse rating	Circuit protected
MULTI FUSE-1	MDPS 1	¹ 	80 A	MDPS Unit
	LDC	LDC	180 A	ICCU
MULTI FUSE-1	IEB1	¹ IEB	60 A	IEB
	BLOWER		40 A	E/R Junction Block (BLOWER RLY)
	RR MIRR HTD		40 A	ICU(REAR HEATED RLY)
	IEB 2	² IEB	60 A	IEB
	POWER OUTLET1	¹ POWER OUTLET	40 A	ICU(POWER OUTLET RLY)

Motor compartment fuse panel (PCB block)

Fuse name	Symbol	Fuse rating	Circuit protected
COOLING FAN		60 A	PE ROOM J/B (COOLING FAN RLY)
IG2	IG2	40 A	PE ROOM J/B (IG2 RLY)
B+4	⁴ 	50 A	ICU
IG1	IG1	30 A	PE ROOM J/B (ACC/IG1 RLY)
E-SHIFTER 1	¹ E-SHIFTER	40 A	SCU
IG3 6	⁶ IG3	40 A	COOLANT_HUB
EWP 1	¹ EWP	40 A	COOLANT_HUB
BMS	BMS	15 A	BMS
HORN		15 A	PE ROOM J/B (HORN RLY, B/ALARM HORN RLY)
A/C1	¹ A/C	15 A	A/C Control Module
OBC	OBC	10 A	ICCU
INVERTER	INVERTER	10 A	INVERTER
IG3 7	⁷ IG3	25 A	PE ROOM J/B (IG3 2 RLY)

Fuse name	Symbol	Fuse rating	Circuit protected
CHARGER	CHARGER	10 A	PE ROOM J/B (CHARGER UNLOCK RLY, CHARGER LOCK RLY)
B+6	⁶ 	10 A	VCMS
EPCU 1	¹ EPCU	15 A	VCU
AMS	AMS	10 A	12 V Battery Sensor
B+3	³ 	40 A	ICU
B+5	⁵ 	30 A	PE ROOM J/B (MAIN RLY)
B+2	² 	40 A	ICU
B+1	¹ 	50 A	ICU
WIPER FRT 1	¹ 	10 A	IBU
EWP2	² EWP	15 A	COOLANT_3WAY_VALVE
IG3 1	¹ IG3	10 A	BMS
E-SHIFTER 2	² E-SHIFTER	10 A	SCU, SBW_LEVER
IG3 8	⁸ IG3	15 A	BATT_EXV, DEHUM_EXV, HEAT_PUMP_EXV, REF_3WAY_VALVE
IG3 2	² IG3	15 A	VCMS

Fuse name	Symbol	Fuse rating	Circuit protected
IG3 3	³ IG3	10 A	VCU, INVERTER, SCU
IG3 4	⁴ IG3	10 A	ICCU
IG3 5	⁵ IG3	10 A	PE J/B(BLOWER RLY, COOLING FAN RLY, IG3 1 RLY), E-COMP, V2L, ICU, FATC, PTC HTR, CLUSTER, AVN, SEAT ECU

Light bulbs

We recommend that you contact an authorized HYUNDAI dealer to replace most vehicle light bulbs. It is difficult to replace vehicle light bulbs because other parts of the vehicle must be removed before you can get to the bulb. This is especially true for removing the headlight assembly to get to the bulb(s).

Removing/installing the headlight assembly may result in damage to the vehicle.

WARNING

- Prior to replacing a light bulb, depress the brake pedal, shift to P (Park), apply the parking brake, press the Start/Stop button to the OFF position and take the key with you when leaving the vehicle to avoid sudden movement of the vehicle and to prevent possible electric shock.
- Be aware the bulbs may be hot and may burn your fingers.

NOTICE

Be sure to replace the burned-out bulb with one of the same wattage to prevent damage to the fuse or electrical wiring system.

NOTICE

To prevent damage, do not clean the headlight lens with chemical solvents or strong detergents.

i Information

This vehicle may be equipped with desiccant to reduce fogging inside the headlight due to moisture. The desiccant is consumable and its performance may change based on the used period or environment. If fogging inside the headlight due to moisture continues for a long time, we recommend that you consult an authorized HYUNDAI dealer.

i Information

The headlight and tail light lenses could appear to have condensation inside if the vehicle is washed after driving or if the vehicle is driven in wet weather. This condition is caused by a higher temperature inside the light and a cooler outside temperature. Moisture that condenses in the light is removed after driving with the light on. If the moisture is not removed, we recommend that you have the vehicle inspected by an authorized HYUNDAI dealer.

i Information

- A normally functioning light may flicker momentarily to stabilize the vehicle's electrical control system. If the light goes out, or continues to flicker, we recommend that you have the system inspected by an authorized HYUNDAI dealer.
- The position light may not turn on when the position light switch is turned on, but the position light and headlight switch may turn on when the headlight switch is turned on. This may be caused by network failure or vehicle electrical control system malfunction. If this occurs, we recommend that you have the system inspected by an authorized HYUNDAI dealer.

i Information

Adjust the headlight aim after an accident or the headlight is replaced.

i Information

Traffic Change

The low beam light distribution is asymmetric. If you go abroad to a country with opposite traffic direction, this asymmetric part will dazzle oncoming car driver. To prevent dazzle, ECE regulation demand several technical solutions (for example, automatic change system, adhesive sheet, down aiming). This headlights are designed not to dazzle opposite drivers. So, you need not change your headlights in a country with opposite traffic direction.

Headlight, position light, turn signal light, daytime running light (DRL) replacement

Type A



- (1) Turn signal light
- (2) Headlight (High/Low)
- (3) Position light/Daytime Running Light (DRL)

If the LED does not operate, we recommend that you have the system inspected by an authorized HYUNDAI dealer.

The LED light cannot be replaced as a single unit. A skilled technician should check or repair the LED light, for it may damage related parts of the vehicle.

Replacing headlight (High/Low)

1. Apply the parking brake and turn off the vehicle.
2. Turn the wheel inwards and remove the clip on the service cover located on the back side of the bumper by using a flat-blade screwdriver.



3. Remove the service cover.
4. Remove the socket cover by turning it counterclockwise.



5. Remove the bulb from the socket by pushing it in and rotating it counterclockwise.
6. Install a new bulb and reinstall in the reverse order.

⚠ WARNING

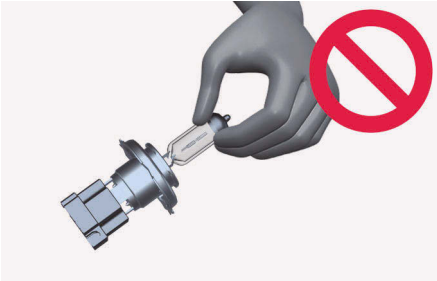

- Handle halogen bulbs with care. Halogen bulbs contain pressurized gas that will produce flying pieces of glass that could cause injuries if broken.
- Wear eye protection when changing a bulb. Allow the bulb to cool down before handling it.
- Always handle them carefully, and avoid scratches and abrasions. If the bulbs are lit, avoid contact with liquids.
- Never touch the glass with bare hands. Residual oil may cause the bulb to overheat and burst when lit.
- A bulb should be operated only when installed in a headlight.
- If a bulb becomes damaged or cracked, replace it immediately and carefully dispose of it.

Type B

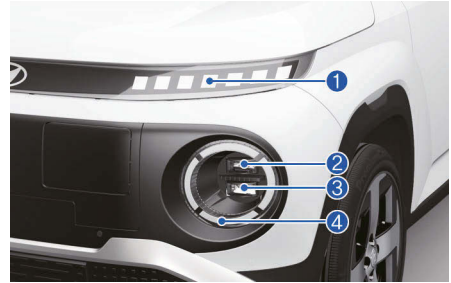

- (1) Turn signal light
- (2) Headlight (Low)
- (3) Headlight (High)
- (4) Position light/Daytime Running Light (DRL)

If the LED light does not operate, we recommend that you have the system inspected by an authorized HYUNDAI dealer.

The LED light cannot be replaced as a single unit. A skilled technician should check or repair the LED light, for it may damage related parts of the vehicle.

Headlight aiming

Headlight aiming



1. Inflate the tires to the specified pressure and remove any loads from the vehicle except the driver, spare tire, and tools.
2. The vehicle should be placed on a flat floor.
3. Draw vertical lines (vertical lines passing through respective headlight centers) and a horizontal line (horizontal line passing through center of headlights) on the screen.
4. With the headlight and battery in normal condition, aim the headlights so the brightest portion falls on the horizontal and vertical lines.
5. To aim the low beam left or right, turn the driver clockwise or counterclockwise. To aim the low beam up or down, turn the driver clockwise or counterclockwise.
To aim the high beam up or down, turn the driver clockwise or counterclockwise.

Aiming point

Type A

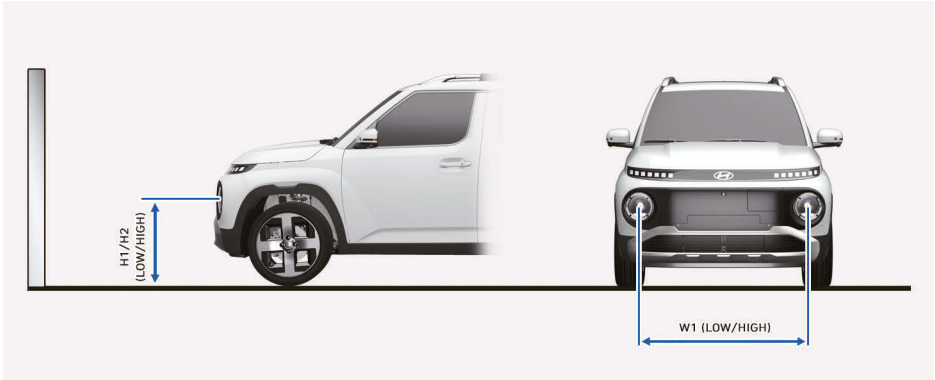

Type B

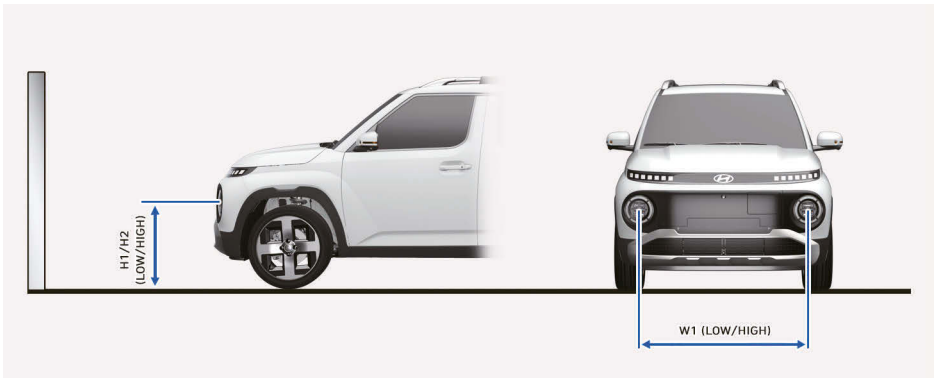

- (1) H1: Height between the headlight center and ground (Low beam)
- (2) H2: Height between the headlight center and ground (High beam)
- (3) W1: Distance between the two headlights centers (Low/High beam)

Vehicle condition		Lamp type	H1	H2	W1
Without driver	mm (in.)	Type A	626 (24.6)	626 (24.6)	1212 (47.7)
		Type B	636 (25)	580 (22.8)	
With driver	mm (in.)	Type A	616 (24.3)	616 (24.3)	1212 (47.7)
		Type B	626 (24.6)	570 (22.4)	

Headlight low beam

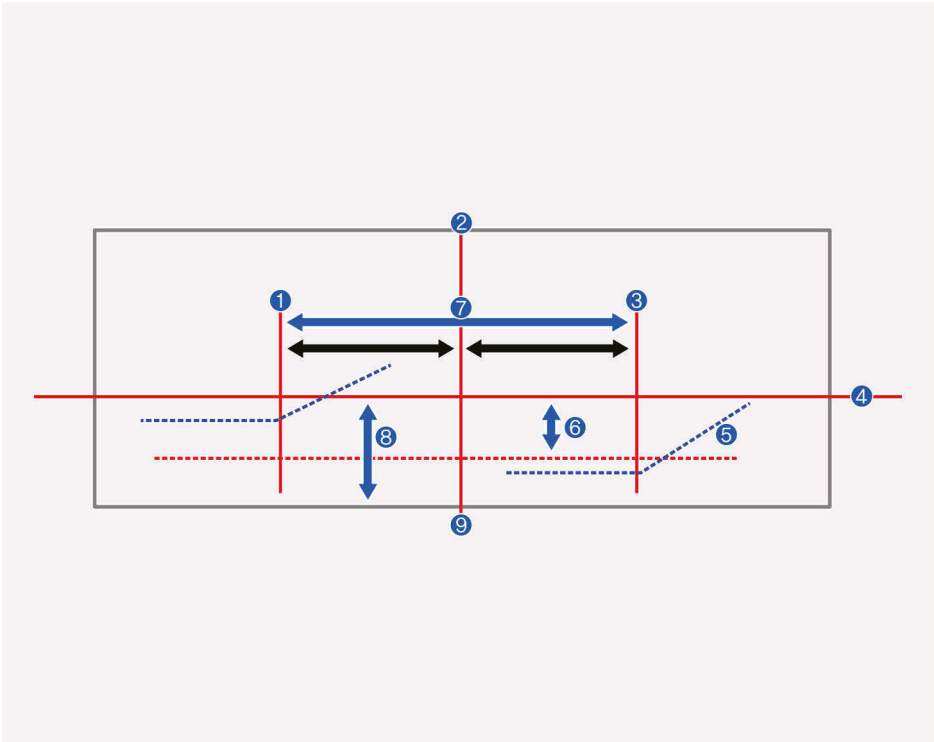

- (1) Vertical line of the left headlight bulb center
- (2) Car axis
- (3) Vertical line of the right headlight bulb center
- (4) Horizontal line of headlight aiming center
- (5) Cut-off line
- (6) 100 mm (Based on 10 m)
- (7) W1 (Low/High beam)
- (8) H1/H2 (Low/High beam)
- (9) Ground

1. Turn the low beam on without driver aboard.
2. The cut-off line should be projected in the cut-off line shown in the picture.
3. When aiming the low beam, vertical aiming should be adjusted after adjusting the horizontal aiming.
4. If headlight leveling device is equipped, adjust the headlight leveling device switch to "0".

Side repeater light replacement

Type A

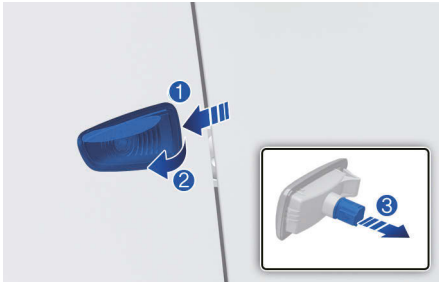

1. Remove the lamp assembly from the vehicle by prying the lens (1) and pulling the assembly out (2).
2. Disconnect the bulb electrical connector.
3. Separate the socket and the lens parts by turning the socket counterclockwise until the tabs on the socket align with the slots on the lens part (3).
4. Remove the bulb by pulling it straight out.
5. Insert a new bulb in the socket.
6. Reassemble the socket and the lens part.
7. Connect the bulb electrical connector.
8. Reinstall the lamp assembly to the body of the vehicle.

Type B



If the side repeater light (1) does not operate, we recommend that the system be inspected by an authorized HYUNDAI dealer.

The LED light cannot be replaced as a single unit. A skilled technician should check or repair the LED light, for it may damage related parts of the vehicle.

Rear combination light replacement

Type A



- (1) Tail light
- (2) Tail/Stop light
- (3) Turn signal light
- (4) Tail sub light
- (5) Rear fog light (Left-hand drive) / Back up light (Right-hand drive)
- (6) Back up light (Left-hand drive) / Rear fog light (Right-hand drive)

If the LED light does not operate, we recommend that you have the system inspected by an authorized HYUNDAI dealer.

The LED light cannot be replaced as a single unit. A skilled technician should check or repair the LED light, for it may damage related parts of the vehicle.

Replacing Stop/Tail light

1. Turn off the vehicle.
2. Open the tailgate.
3. Remove the fixing screw bolt (1) located inside the handle of tailgate lead trim. Use clip remover driver (2) to remove clip fixed in the tailgate panel. Or remove it by pulling the handle hard to disassemble the trim (3).

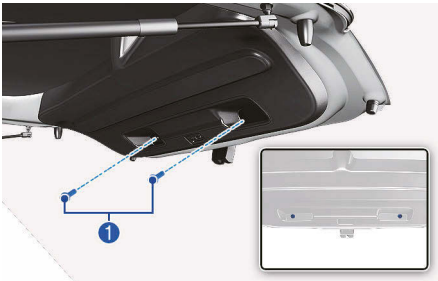

4. After disassembling the connector, remove the fixing nut from the body.
5. Pull the body backwards to remove it from the vehicle.

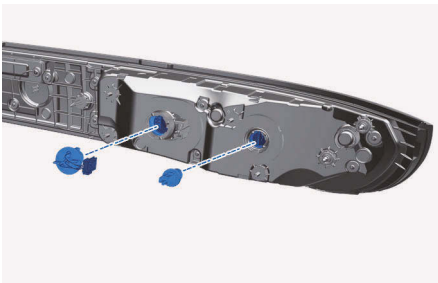

6. Remove the socket from the assembly by turning the socket counterclockwise.
7. Insert a new bulb by inserting it into the socket and rotating it until it locks into place.
8. Install the socket into the assembly by aligning the tabs on the socket with the slots in the assembly. Push the socket into the assembly and turn the socket clockwise.
9. Reinstall the lamp assembly to the body of the vehicle.

Type B



- (1) Tail/Stop light
- (2) Turn signal light
- (3) Tail sub light
- (4) Rear fog light (Left-hand drive) / Back up light (Right-hand drive)
- (5) Back up light (Left-hand drive) / Rear fog light (Right-hand drive)

If the LED light does not operate, we recommend that your vehicle be inspected by an authorized HYUNDAI dealer.

The LED light cannot be replaced as a single unit. A skilled technician should check or repair the LED light, for it may damage related parts of the vehicle.

High mounted stop light replacement

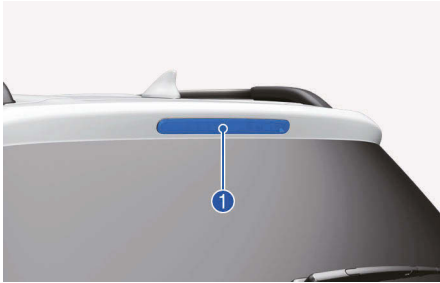

If the LED light (1) does not operate, we recommend that you have the system inspected by an authorized HYUNDAI dealer.

The LED light cannot be replaced as a single unit. A skilled technician should check or repair the LED light, for it may damage related parts of the vehicle.

License plate light replacement

License plate light (bulb type)



1. Remove the lens gently by using a flat-blade screwdriver.
2. Remove the socket from the lamp assembly by turning it counterclockwise.

3. Press the connector clip and pull the connector from the socket.
4. Insert a new bulb and reinstall the lamp assembly in the reverse order.

License plate light (LED type)

If the LED light does not operate, we recommend that you have the system inspected by an authorized HYUNDAI dealer.

The LED light cannot be replaced as a single unit. A skilled technician should check or repair the LED light, for it may damage related parts of the vehicle.

Interior light replacement

Map lamp, room lamp, vanity mirror lamp, mood lamp and cargo area lamp (LED type)

Map lamp



Room lamp



Vanity mirror lamp



Mood lamp

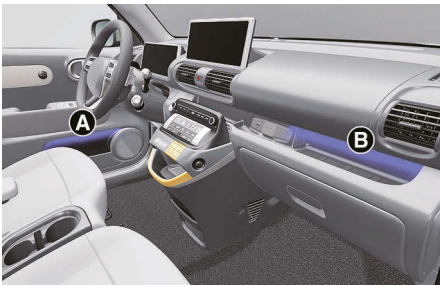

Cargo area lamp

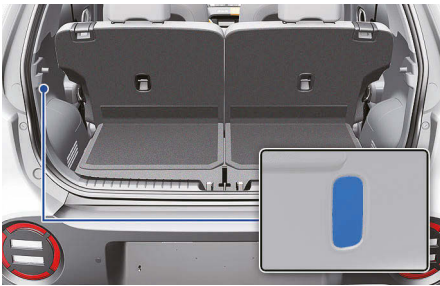

Map lamp, room lamp, vanity mirror lamp and cargo area lamp (Bulb type)

Map lamp



Room lamp

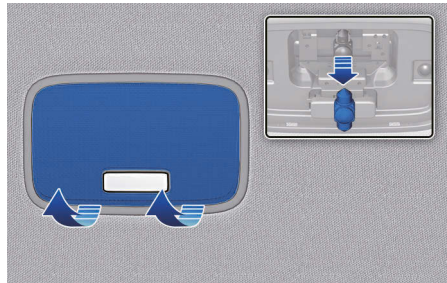

Vanity mirror lamp



If the LED lamp does not operate, we recommend that your vehicle be inspected by an authorized HYUNDAI dealer.

The LED light cannot be replaced as a single unit. A skilled technician should check or repair the LED light, for it may damage related parts of the vehicle.

Cargo area lamp

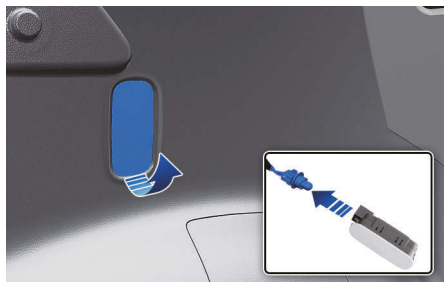

1. Using a flat-blade screwdriver, gently pry the lens from the interior light housing.
2. Remove the bulb by pulling it straight out.
3. Install a new bulb into the socket.
4. Align the lens tabs with the interior light housing notches and snap the lens into place.

NOTICE

Be careful not to damage the cover, tab, and plastic housing.

Appearance care

Exterior care

NOTICE

If you park your vehicle near a stainless steel sign or glass facade building, the vehicle's exterior plastic parts such as a bumper, spoiler, garnish, lamp or outside rearview mirror might be damaged due to sunlight reflected from the sign or building. To prevent damage of the exterior plastic parts, you should avoid parking in areas where light may be reflected or use a car cover. (The exterior plastic parts applied to your vehicle may vary.)

Exterior general caution

It is very important to follow the label directions when using any chemical cleaner or polish. Read all warning and caution statements that appear on the label.

Finish maintenance

Washing

To help protect your vehicle's finish from rust and deterioration, wash it thoroughly and frequently at least once a month with lukewarm or cold water.

If you use your vehicle for off-road driving, you should wash it after each off-road trip. Pay special attention to the removal of any accumulation of salt, dirt, mud, and other foreign materials. Make sure the drain holes in the lower edges of the doors and rocker panels are kept clear and clean.

Insects, tar, tree sap, bird droppings, industrial pollution and similar deposits can damage your vehicle's finish if not removed immediately.

Even prompt washing with plain water may not completely remove all these deposits. A mild soap, safe for use on painted surfaces, should be used.

After washing, rinse the vehicle thoroughly with lukewarm or cold water. Do not allow soap to dry on the finish.

High-pressure washing

- When using high-pressure washers, make sure to maintain sufficient distance from the vehicle.
Insufficient clearance or excessive pressure can lead to component damage or water penetration.
- Do not spray the camera, sensors or its surrounding area directly with a high pressure washer. Shock applied from high pressure water may cause the device to not operate normally.
- Do not bring the nozzle tip close to boots (rubber or plastic covers) or connectors as they may be damaged if they come into contact with high pressure water.

WARNING

After washing the vehicle, test the brakes while driving slowly to see if they have been affected by water before getting on the road. If braking performance is impaired, dry the brakes by applying them lightly while maintaining a slow forward speed.

NOTICE

- Do not use strong soap, chemical detergents or hot water, and do not wash the vehicle in direct sunlight or when the body of the vehicle is warm.
- Be careful when washing the side windows of your vehicle.
- Especially, with high-pressure water, water may leak through the windows and wet the interior.

- To prevent damage to the plastic parts, do not clean with chemical solvents or strong detergents.



- Water washing in the motor compartment including high pressure water washing may cause the failure of electrical circuits located in the vehicle compartment.
 - Never allow water or other liquids to come in contact with electrical/electronic components inside the vehicle as water or other liquids may flow in to the motor compartment through the damage electrical/electronic components.
-

NOTICE

Matte paint finish vehicle (if equipped)
Automatic car wash which uses rotating brushes should not be used as this can damage the surface of your vehicle. A steam cleaner which washes the vehicle surface at high temperature may result the oil to adhere and leave stains that is difficult to remove.

Use a soft cloth (for example, microfiber towel or sponge) when washing your vehicle and dry with a microfiber towel. When you hand wash your vehicle, you should not use a cleaner that finishes with wax. If the vehicle surface is too dirty (sand, dirt, dust, contaminant, etc.), clean the surface with water before washing the car.

Waxing

A good coat of wax is a barrier between your paint and contaminants. Keeping a good coat of wax on your vehicle will help protect it.

Wax the vehicle when water will no longer bead on the paint.

Always wash and dry the vehicle before waxing. Use a good quality liquid or paste wax, and follow the manufacturer's instructions. Wax all metal trim to protect it and to maintain its luster.

Removing oil, tar, and similar materials with a spot remover will usually strip the wax from the finish. Be sure to re-wax these areas even if the rest of the vehicle does not yet need waxing.

NOTICE

- Wiping dust or dirt off the body with a dry cloth will scratch the finish.
- Do not use steel wool, abrasive cleaners, or strong detergents containing highly alkaline or caustic agents on chrome-plated or anodized aluminum parts. This may result in damage to the protective coating and cause discoloration or paint deterioration.

NOTICE

Matte paint finish vehicle (if equipped)
Do not use any polish protector such as a detergent, an abrasive and a polish. In case wax is applied, remove the wax immediately using a silicon remover and if any tar or tar contaminant is on the surface use a tar remover to clean. However, be careful not to apply too much pressure on the painted area.

Finish damage repair

Deep scratches or stone chips in the painted surface must be repaired promptly. Exposed metal will quickly rust and may develop into a major repair expense.

NOTICE

If your vehicle is damaged and requires any metal repair or replacement, be sure the body shop applies anti-corrosion materials to the parts repaired or replaced.

NOTICE

Matte paint finish vehicle (if equipped)

In case of matte paint finish vehicles, it is impossible to modify only the damaged area and repair of the whole part is necessary. If the vehicle is damaged and painting is required, we recommend that you have your vehicle maintained and repaired by an authorized HYUNDAI dealer. Take extreme care, as it is difficult to restore the quality after the repair.

Bright-metal maintenance

- To remove road tar and insects, use a tar remover, not a scraper or other sharp object.
- To protect the surfaces of bright metal parts from corrosion, apply a coating of wax or chrome preservative and rub to a high luster.
- During winter weather or in coastal areas, cover the bright metal parts with a heavier coating of wax or preservative. If necessary, coat the parts with non-corrosive petroleum jelly or other protective compound.

Underbody maintenance

Corrosive materials used for ice and snow removal and dust control may collect on the underbody. If these materials are not removed, accelerated rusting can occur on underbody parts such as the frame and floor pan, even though they have been treated with rust protection.

Thoroughly flush the vehicle underbody and wheel openings with lukewarm or cold water once a month, after off-road driving and at the end of each winter. Pay special attention to these areas because it is difficult to see all the mud and dirt. It will do more harm than good to wet down the road grime without removing it. The lower edges of doors, rocker panels, and frame members have drain holes that should not be allowed to clog with dirt; trapped water in these areas can cause rusting.

WARNING

After washing the vehicle, test the brakes while driving slowly to see if they have been affected by water. If braking performance is impaired, dry the brakes by applying them lightly while maintaining a slow forward speed.

Aluminum wheel maintenance

The aluminum wheels are coated with a clear protective finish.

- Do not use abrasive cleaner, polishing compound, solvent, or wire brushes on aluminum wheels.
- Clean the wheel when it has cooled.
- Use only a mild soap or neutral detergent, and rinse thoroughly with water. Also, clean the wheels after driving on salted roads.
- Do not wash the wheels with high-speed car wash brushes.
- Do not use any cleaners containing acid or alkaline detergents.

Corrosion protection

Protecting your vehicle from corrosion

By using the most advanced design and construction practices to combat corrosion, HYUNDAI produces vehicles of the highest quality. However, this is only part of the job. To achieve the long-term corrosion resistance your vehicle can deliver, the owner's cooperation and assistance is also required.

Common causes of corrosion

The most common causes of corrosion on your vehicle are:

- Road salt, dirt and moisture that is allowed to accumulate underneath the vehicle.
- Removal of paint or protective coatings by stones, gravel, abrasion or minor scrapes and dents which leave unprotected metal exposed to corrosion.

High-corrosion areas

If you live in an area where your vehicle is regularly exposed to corrosive materials, corrosion protection is particularly important. Some of the common causes of accelerated corrosion are road salts, dust control chemicals, ocean air and industrial pollution.

Moisture breeds corrosion

Moisture creates the conditions in which corrosion is most likely to occur. For example, corrosion is accelerated by high humidity, particularly when temperatures are just above freezing. In such conditions, the corrosive material is kept in contact with the vehicle surfaces by moisture that is slow to evaporate.

Mud is particularly corrosive because it is slow to dry and holds moisture in contact with the vehicle. Although the mud appears to be dry, it can still retain moisture and promote corrosion.

High temperatures can also accelerate corrosion of parts that are not properly ventilated so the moisture can be dispersed. For all these reasons, it is particularly important to keep your vehicle clean and free of mud or accumulations of other materials. This applies not only to the visible surfaces but particularly to the underside of the vehicle.

To help prevent corrosion

Keep your vehicle clean

The best way to prevent corrosion is to keep your vehicle clean and free of corrosive materials. Attention to the underside of the vehicle is particularly important.

- If you live in a high-corrosion area – where road salts are used, near the ocean, areas with industrial pollution, acid rain, etc., you should take extra care to prevent corrosion. In winter, hose off the underside of your vehicle at least once a month and be sure to clean the underside thoroughly when winter is over.
- When cleaning underneath the vehicle, pay particular attention to the components under the fenders and other areas that are hidden from view. Do a thorough job; just dampening the accumulated mud rather than washing it away will accelerate corrosion rather than prevent it. Water under high pressure and steam are particularly effective in removing accumulated mud and corrosive materials.
- When cleaning lower door panels, rocker panels and frame members, be sure that drain holes are kept open so that moisture can escape and not be trapped inside to accelerate corrosion.

Keep your garage dry

Don't park your vehicle in a damp, poorly ventilated garage. This creates a favorable environment for corrosion. This is particularly true if you wash your vehicle in the garage or drive it into the garage when it is still wet or covered with snow, ice or mud. Even a heated garage can contribute to corrosion unless it is well ventilated so moisture is dispersed.

Keep paint and trim in good condition

Scratches or chips in the finish should be covered with "touch-up" paint as soon as possible to reduce the possibility of corrosion. If bare metal is showing through, the attention of a qualified body and paint shop is recommended.

Bird droppings are highly corrosive and may damage painted surfaces in just a few hours. Always remove bird droppings as soon as possible.

Interior care

Interior general precautions

Prevent caustic solutions such as perfume and cosmetic oil, from contacting the interior parts because they may cause damage or discoloration. If they do contact the interior parts, wipe them off immediately. See the instructions for the proper way to clean vehicle interior surfaces.

NOTICE

- Never allow water or other liquids to come in contact with electrical/electronic components inside the vehicle as this may damage them.
- When cleaning leather products (steering wheel, seats etc.), use neutral detergents or low alcohol content solutions. If you use high alcohol content solutions or acid/ alkaline detergents, the color of the leather may fade or the surface may get stripped off.

Cleaning the upholstery and interior trim

Vehicle interior surfaces (if equipped)

Remove dust and loose dirt from interior surfaces with a whisk broom or a vacuum cleaner. If necessary, clean interior surfaces with a mixture of warm water and mild non-detergent cleaner (test all cleaners on a concealed area before use).

Fabric (if equipped)

Remove dust and loose dirt from fabric with a whisk broom or vacuum cleaner. Clean with a mild soap solution recommended for upholstery or carpets. Remove fresh spots immediately with a fabric spot cleaner. If fresh spots do not receive immediate attention, the fabric can be stained and its color can be affected. Also, its fire-resistant properties can be reduced if the material is not properly maintained.

NOTICE

Using anything but recommended cleaners and procedures may affect the fabric's appearance and fire-resistant properties.

Leather (if equipped)

- Features of seat leather
 - Leather is made from the outer skin of an animal, which goes through a special process to be available for use. Since it is a natural product, each part differs in thickness or density. Wrinkles may appear as a natural result of stretching and shrinking depending on the temperature and humidity.
 - The seat is made of stretchable fabric to improve comfort.
 - The parts contacting the body are curved and the side supporting area is high which provides driving comfort and stability.
 - Wrinkles may appear naturally from usage. It is not a fault of the products.

NOTICE

- Wrinkles or abrasions which appear naturally from usage are not covered by warranty.
- Belts with metallic accessories, zippers or keys inside the back pocket may damage the seat fabric.
- Make sure not to wet the seat. It may change the nature of natural leather.
- Jeans or clothes which could bleach may contaminate the surface of the seat covering fabric.

-
- Caring for the leather seats
 - Vacuum the seat periodically to remove dust and sand on the seat. It will prevent abrasion or damage of the leather and maintain its quality.
 - Wipe the natural leather seat cover often with dry or soft cloth.
 - Use of proper leather protector may prevent abrasion of the cover and helps maintain the color. Be sure to read the instructions and consult a specialist when using leather coating or protective agent.
 - Light colored (beige, cream beige, etc.) leather is easily contaminated and the stain is noticeable. Clean the seats frequently.
 - Avoid wiping with wet cloth. It may cause the surface to crack.
 - Cleaning the leather seats
 - Remove all contaminations instantly. Refer to the instructions below for removal of each contaminant.
 - Cosmetic products (sunscreen, foundation, etc.)

Apply cleansing cream on a cloth and wipe the contaminated spot. Wipe off the cream with a wet cloth and remove water with a dry cloth.

- Beverages (coffee, soft drink, etc.)

Apply a small amount of neutral detergent and wipe until contaminations do not smear.
- Oil

Remove oil instantly with absorbable cloth and wipe with stain remover used only for natural leather.
- Chewing gum

Harden the gum with ice and remove gradually.

Cleaning the seat belt webbing

Clean the belt webbing with any mild soap solution recommended for cleaning upholstery or carpet. Follow the instructions provided with the soap. Do not bleach or re-dye the webbing because this may weaken the seat belt.

Cleaning the interior window glass

If the interior glass surfaces of the vehicle become fogged (that is, covered with an oily, greasy or waxy film), they should be cleaned with glass cleaner. Follow the directions on the glass cleaner container.

NOTICE

Do not scrape or scratch the inside of the rear window. This may result in damage to the rear window defroster grid.

Appendix

Vetrarakstur (íslenskur)	A-2
Snjór eða hálfka	A-2
Barnaöryggisbúnaður (CRS) (ÍSLENSKA)	A-4

Vetrarakstur (Íslenskur)

Snjór eða hálfka

Þú þarft að halda nægilegri fjarlægð milli ökutækisins þíns og ökutækisins fyrir framan þig.

Beittu bremsunum varlega. Að aka of hratt, hraða hröðun, skyndilegum hemlum og skörpum beygjum eru mjög hættuleg atriði. Skyndileg bremsa á snjóugum eða ísilögðum vegum getur valdið því að ökutækið rennur.

Til að aka í djúpum snjó gæti verið nauðsynlegt að nota nagladekk eða setja keðjur á dekkinn þín.

Hafðu alltaf neyðarbúnað meðferðis. Þú gætir viljað hafa dekkjakeðjur, dráttaról eða keðjur, vasaljós, neyðarblys, sand, skóflu, ræsiklemmur, ísskafa, hanska, undirlag, samfestinga, teppi o.s.frv.

Nagladekk

⚠ WARNING

Nagladekk skulu vera sambærileg að stærð og gerð við venjuleg dekk ökutækisins. Annars gæti öryggi og stjórnun ökutækisins orðið fyrir áhrifum.

Notaðu nagladekk þegar hitastig á vegum er undir 7 °C (45 °F). Ef þú setur nagladekk á ökutækið þitt, vertu viss um að nota sama loftþrýsting og í upprunalegu dekkjunum. Settu nagladekk á öll fjögur hjólin til að jafna stjórnun ökutækisins við allar veðuraðstæður.

Gripið sem nagladekk veita á þurrum vegum er kannski ekki eins mikið og í upprunalegum dekkjum ökutækisins. Hafðu samband við dekkjasala um hámarkshraðatillögur.

Dekkja keðjur

Virkeðjur



Efniskeðjur



Þar sem hliðar radialdekkja eru þynnri en á öðrum tegundum dekkja, geta þau skemmst við að setja sumar tegundir dekkjakeðja á þau. Þess vegna er mælt með því að nota nagladekk í stað dekkjakeðja. Ef nota þarf dekkjakeðjur, notið aðeins keðjur sem henta þessu ökutæki og setjið keðjurnar á eftir að hafa skoðað leiðbeiningarnar sem fylgja keðjunum. Skemmdir á ökutækinu af völdum rangrar notkunar dekkjakeðja eru ekki í ábyrgð framleiðanda ökutækisins.

! WARNING

Notkun dekkjakeðja getur haft áhrif á stjórnun ökutækisins:

- Keyrðu minna en 30 km/klst (20 mph) eða lægsta hraðatakmark sem framleiðandi keðjunnar mælir með, hvort sem er lægra.
- Keyrðu varlega og forðastu högg, holur, skarpar beygjur og aðrar vegahættur sem gætu valdið því að ökutækið hoppi.
- Forðastu skarpar beygjur eða hemlun með læstum hjólum.
- Settu keðjur á dekk aðeins í pörum og á framdekk. Að setja keðjur á dekk eykur dráttaraflið, en kemur ekki í veg fyrir hliðarskrið.

i Information

Settu ekki á nagladekk án þess að athuga fyrst reglur á staðnum eða í bænum varðandi mögulegar takmarkanir á notkun þeirra.

Keðjuuppsetning

Þegar þú setur upp dekkjakeðjur, fylgdu leiðbeiningum framleiðandans og herðu þær eins og mögulegt er. Keyrðu hægt (minna en 30 km/klst (20 mph) eða lægsta hraðatakmark sem framleiðandi keðjunnar mælir með) með keðjurnar á. Ef þú heyrir keðjurnar slá á karosseríð eða grindina, stoppaðu og herðið þær. Ef þær slá ennþá, hægðu á þér þar til hljóðið hættir. Fjarlægðu dekkjakeðjur um leið og þú byrjar að keyra á hreinsuðum vegum.

Þegar þú setur snjókeðjur á, leggðu ökutækið á sléttu svæði í burtu frá umferð. Kveiktu á neyðarblikki ökutækisins og settu þríhyrnt neyðarmerki á bak við ökutækið (ef það er til staðar). Settu alltaf ökutækið í P (Park), notaðu rafbremsuna (EPB) og slökktu á ökutækinu áður en þú setur upp snjókeðjur.

NOTICE

Þegar þú notar dekkjakeðjur:

- Rangar keðjur eða ranglega settar keðjur geta skemmt bremsulínur, fjöðrun, karosserí og hjól ökutækisins.
- Notaðu aðeins keðjur sem henta þessu ökutæki, eins og SAE "S" flokks vírkeðjur sem eru minna en 12 mm (0.47 in.) þykkar eða vefja keðjur. Hins vegar skaltu ekki nota vírkeðjur á 17 tommu dekkjum.
- Ef þú heyrir hávaða af völdum keðja sem snerta karosseríð, herðið þær til að koma í veg fyrir snertingu við ökutækið.
- Til að koma í veg fyrir skemmdir á karosseríinu, herðið keðjurnar eftir að hafa keyrt 0,5-1,0 km (0.3-0.6 mi.).
- Forðastu að nota málmkeðjur á álfelgum þar sem þetta getur skemmt hjólið.

Barnaöryggisbúnaður (CRS) (ÍSLENSKA)

Hæfni hvers sætis fyrir belt og ISOFIX barnabílstóla samkvæmt reglugerðum SP

(Upplýsingar fyrir öikumenn ökutækja og framleiðendur barnabílstóla)

- Já: Hentugt fyrir festingu tilgreindrar flokkunar barnabílstóla.
- Nei: Ekki hentugt fyrir festingu tilgreindrar flokkunar barnabílstóla.
- -: Á ekki við.
- Taflan byggir á ökutæki með stýri vinstra megin. Fyrir utan framsæti farþega gildir taflan einnig fyrir ökutæki með stýri hægra megin. Fyrir framsæti farþega í ökutæki með stýri hægra megin, notið upplýsingar fyrir sæti númer 3.

Flokkar barnaöryggisbúnaðar		Sætisstaður				
		1,2	3		4	5
			Loftpúði ON	Loftpúði SLÖKKT		
Alhliða belt CRS	Allir fjöldahópar	-	Nei	Já* F, R	Já F, R	Já F, R
i-stærð CRS	ISOFIX CRF: F2, F2X, R1, R2	-	Nei	Nei	Já F, R	Já F, R
Barnarúm (ISOFIX hlið sem snýr CRS)	ISOFIX CRF: L1, L2	-	Nei	Nei	Nei	Nei
ISOFIX ungbarna* CRS (*: ISOFIX baby CRS)	ISOFIX CR: R1	-	Nei	Nei	Já R	Já R
ISOFIX smábarn CRS - lítið	ISOFIX CRF: F2, F2X, R2, R2X	-	Nei	Nei	Já F, R	Já F, R
ISOFIX CRS fyrir smábarn - stórt*(*: ekki aukastólar)	ISOFIX CRF: F3, R3	-	Nei	Nei	Já F, R	Já F, R
Booster Seat - minni breidd	ISO CRF: B2	-	Nei	Nei	Já	Já
Booster Seat - í fullri breidd	ISO CRF: B3	-	Nei	Nei	Já	Já

*1 Til að setja upp alhliða barnabílstól (CRS) skal stilla framsæti í 1. röð í viðeigandi stöðu sem truflar ekki stöðuga uppsetningu (stilltu í mögulega hæðar- eða upprétta stöðu).

Information

F: Fram á við, R: Aftur á bak

i Information

- Ef höfuðpúði ökutækisins kemur í veg fyrir rétta uppsetningu barnabílstóls, skal stilla höfuðpúðann á sætisstöðunni eða fjarlægja hann alveg.
- Aldrei skal setja afturvísandi barnabílstól á framsæti farþega, nema loftpúðinn sé óvirkur.
- Fyrir hálfuniversalan eða ökutækjasértækan barnabílstól (ISOFIX eða beltabundinn barnabílstól) skaltu skoða ökutækjalistann sem fylgir með leiðbeiningunum fyrir barnabílstólinn.
- Þegar barnabílstóll er settur upp í sætum í 2. sætaröð, skal færa sætið í miðstöðu.

i Information

- Ef höfuðpúðar koma í veg fyrir rétta uppsetningu barnabílstóls, skal stilla höfuðpúðana á sætisstöðunni eða fjarlægja þá alveg.
- Aldrei skal setja afturvísandi barnabílstól á framsæti farþega, nema loftpúðinn sé óvirkur.

Sætisnúmer	Staða í ökutækinu	Sætisstaður
1	Framan til vinstri	
2	Fremri miðju	
3	Framan til hægri	
4	2. röð til vinstri	
5	2. röð til hægri	

Ráðlögð barnaöryggisbúnaður

Hæð barns	Nafn	Framleiðandi	Tegund festingar
40 – 83 cm	BABY-SAFE 3 i-Size með FLEX BASE i-Sense	Britax	ISOFIX með studdum fæti (RWF)
76 – 105 cm	Trifix2 i-Size	Britax	ISOFIX festur með topptjóðrun
100 – 150 cm	Lausn T i-Fix	Cybex	ISOFIX
135 – 150 cm	Grunnstuðningur R129	Graco	Ökutæki belti

Upplýsingar um CRS framleiðanda

Britax: <https://www.britax-roemer.com/>

Cybex: <https://www.cybex-online.com/>

Graco: <https://www.graco.com>

Index

A

About "Getting started with your electric vehicle" 1-8

Accessing your vehicle 5-5

 Immobilizer system 5-9

 Smart key 5-5

Active air flap 6-39

 Malfunction 6-39

Air conditioner compressor label 2-22

Air conditioning system 2-19

Air ventilation seats 3-17

Airbag - supplemental restraint system 3-36

 Additional safety precautions 3-51

 Airbag warning labels 3-52

 Do not install a Child Restraint System on the front passenger's seat 3-47

 How does the airbags system operate? 3-43

 SRS care 3-51

 SRS Components 3-39

 SRS warning light 3-47

 What to expect after an airbag inflates 3-46

 Where are the airbags? 3-40

 Why didn't my airbag go off in a collision? 3-48

Appearance care 9-51

 Exterior care 9-51

 Interior care 9-56

Automatic climate control system 5-58

 Automatic heating and air conditioning 5-59

 Manual heating and air conditioning 5-60

 System maintenance 5-67

 System operation 5-66

Aux. Battery Saver+ 1-48

B

Barnaöryggisbúnaður (CRS) A-4

Battery (12 V) 9-19

 Battery capacity label 9-20

 Battery recharging 9-20

 For best battery service 9-20

 Reset items 9-21

Before driving 6-3

 Before entering the vehicle 6-3

 Before starting 6-3

Blind-Spot Collision-Avoidance Assist (BCA) 7-42

 Blind-Spot Collision-Avoidance Assist malfunction and limitations 7-48

 Blind-Spot Collision-Avoidance Assist operation 7-45

 Blind-Spot Collision-Avoidance Assist settings 7-44

Blind-Spot View Monitor (BVM) 7-81

 Blind-Spot View Monitor malfunction 7-83

 Blind-Spot View Monitor operation 7-82

 Blind-Spot View Monitor settings 7-82

Brake fluid	9-14
Checking the brake fluid level	9-14
Braking system	6-23
Anti-lock brake system (ABS)	6-30
Auto hold	6-27
Brake assistant system (BAS)	6-36
Brake Disc Cleaning	6-29
Disc brakes wear indicator	6-24
Electronic parking brake (EPB)	6-24
Electronic stability control (ESC)	6-31
Emergency Stop Signal (ESS)	6-35
Good braking practices	6-36
Hill-start assist control (HAC)	6-34
Multi-collision brake (MCB)	6-35
Power-assist brakes	6-23
Vehicle stability management (VSM)	6-33
Bulb wattage	2-16

C

Cabin air filter	9-16
Filter inspection	9-16
Filter replacement	9-16
Center console overview	2-9
Charging your electric vehicle	1-12
Checking basic information on charging your electric vehicle	1-16
Checklist when charging does not start	1-30
Safety precautions for charging your electric vehicle	1-12
Using a DC Charger	1-23
Using a portable charger (ICCB)	1-25
Using an AC charger	1-21
Using the scheduled charging function	1-29
Child Restraint System (CRS)	3-26
Installing a Child Restraint System	3-28
Our recommendation: Children at middle position	3-26
Selecting a Child Restraint System (CRS)	3-27
Climate control additional features	5-72
Auto defogging system	5-72
Auto dehumidify	5-73
Link to climate settings for auto-adjustment	5-74
Recirculating air when washer fluid is used	5-73
Cluster display (Type A)	4-20
Cluster display control	4-20
Cluster display modes	4-21
Trip computer	4-29
User settings mode	4-23
Cluster display (Type B)	4-31
Cluster display control	4-31
View modes	4-31
Coolant	9-12
Changing coolant	9-13

Countermeasures for accidents or fire	1-60
If the electric vehicle catches fire	1-60
If the electric vehicle is submerged	1-60
If the electric vehicle needs towing	1-61
Other precautions for electric vehicle accidents	1-62
Cruise Control (CC)	7-83
Cruise Control operation	7-83

D

Declaration of conformity	2-22, 7-157
Front radar	7-157
Rear corner radar	7-159
Dimensions	2-15
Door locks	5-19
Auto Door Lock/Unlock Features	5-22
Child-protector rear door locks	5-22
Operating door locks from outside the vehicle	5-19
Operating door unlocks from inside the vehicle	5-20
Drive mode integrated control system	6-37
Drive mode	6-37
Drive mode characteristic	6-38
Driver assistance system	7-1
Driver assistance system notice	7-4
Driver Attention Warning (DAW)	7-70
Driver Attention Warning malfunction and limitations	7-73
Driver Attention Warning operation	7-71
Driver Attention Warning settings	7-71
Driving your electric vehicle	1-49
Checking electric vehicle driving information	1-50
Starting and stopping the vehicle	1-49

E

Electric charging door	5-41
Closing the electric charging door	5-41
Opening the electric charging door	5-41
Electric vehicle specifications	2-15
Emergency commodity	8-19
Fire extinguisher	8-19
First aid kit	8-19
Tire pressure gauge	8-19
Triangle reflector	8-19
Explanation of scheduled maintenance items	9-11
Air conditioning refrigerant	9-11
Brake discs, pads, calipers and rotors	9-11
Brake fluid	9-11
Brake hoses and lines	9-11
Coolant	9-11
Cooling system	9-11
Drive shafts and boots	9-11

Reduction gear fluid	9-11
Steering gear box, linkage & boots/lower arm ball joint	9-11
Suspension mounting bolts	9-11
Exterior features	5-85
Roof basket	5-86
Roof side rails	5-85
Exterior lights	5-44
Battery saver function	5-47
Daytime Running Light (DRL)	5-49
Headlight delay function	5-48
Headlight leveling device	5-47
High beam operation	5-46
Interior Lights Always On	5-48
Lighting control	5-44
Rear fog light	5-47
Turn signals and lane change signals	5-46
Welcome system	5-49
Exterior overview (Front View)	2-2
Exterior overview (Rear View)	2-4

F

Forward Attention Warning (FAW)	7-76
Forward Attention Warning malfunction and limitations	7-79
Forward Attention Warning operation	7-77
Forward Attention Warning settings	7-77
Forward Collision-Avoidance Assist (FCA) (Front view camera only)	7-4
Forward Collision-Avoidance Assist malfunction and limitations	7-10
Forward Collision-Avoidance Assist settings	7-5
Forward Collision-Avoidance Assist (FCA) (Sensor fusion)	7-17
Forward Collision-Avoidance Assist malfunction and limitations	7-27
Forward Collision-Avoidance Assist operation	7-7, 7-20
Forward Collision-Avoidance Assist settings	7-19
Forward/Reverse Parking Distance Warning (PDW)	7-144
Forward/Reverse Parking Distance Warning malfunction and limitations	7-148
Forward/Reverse Parking Distance Warning operation	7-146
Forward/Reverse Parking Distance Warning settings	7-145
Fuses	9-29
Fuse/relay panel description	9-32
Instrument panel fuse replacement	9-30
Motor compartment panel fuse replacement	9-30

H

Hazard warning flasher	8-2
High Beam Assist (HBA)	5-50
High Beam Assist malfunction and limitations	5-51
High Beam Assist operation	5-50
High Beam Assist settings	5-50
Highway Driving Assist (HDA)	7-113
Highway Driving Assist Malfunction and Limitations	7-118

Highway Driving Assist Operation	7-115
Highway Driving Assist Settings	7-114
Hood	5-38
Closing the hood	5-39
Opening the hood	5-38
Hyundai Digital Key	5-10
Digital key (Card key)	5-15
Digital key (smartphone)	5-10
Limitations of the system	5-19
Used vehicle/Digital key maintenance	5-18

I

If the vehicle does not start	8-3
Confirm the EV battery is not low on the charge gauge	8-3
If you have a flat tire (with Tire Mobility Kit)	8-10
Components of the Tire Mobility Kit	8-13
How to adjust tire pressure	8-16
Introduction	8-11
Notes on the safe use of the Tire Mobility	8-11
Using the Tire Mobility Kit when a tire is flat	8-14
Important safety precautions	3-3
Airbag hazards	3-3
Always wear your seat belt	3-3
Control your speed	3-4
Driver distraction	3-3
Keep your vehicle in safe condition	3-4
Never drink or take drugs and drive	3-3
Restrain all children	3-3
IMPORTER & DISTRIBUTOR INFORMATION FOR EU BATTERY REGULATION (EU 2023/1542) ..	
.....	2-23
Importer information (for Europe)	2-22
In case of an emergency while driving	8-2
If the vehicle stalls at a crossroad or crossing	8-2
If the vehicle stalls while driving	8-2
If you have a flat tire while driving	8-3
Information	1-3
Infotainment system	5-87
Antenna	5-88
Bluetooth® wireless technology	5-89
Infotainment system	5-89
Steering wheel remote controls	5-88
USB Port	5-87
Voice recognition	5-89
Instrument cluster	4-2
Cluster display messages	4-16
Gauges and meters	4-3
Instrument cluster control	4-3
Reduction gear shift indicator	4-5
Warning and indicator lights	4-6

Intelligent Speed Limit Assist (ISLA)	7-62
Intelligent Speed Limit Assist Malfunction and Limitations	7-67
Intelligent Speed Limit Assist Operation	7-65
Intelligent Speed Limit Assist Settings	7-63
Interior features	5-76
Cargo area cover	5-84
Cargo security screen	5-84
Coat hook	5-81
Cup holder	5-76
Floor mat anchor(s)	5-83
Power outlet	5-77
Seatback board	5-76
Shopping bag hook	5-81
Sunvisor	5-77
Upper garnish	5-82
USB charger	5-78
Van package	5-82
Vehicle to load (V2L)	5-80
Wireless smartphone charging system	5-79
Interior lights	5-52
Ambient light	5-54
Cargo area lamp	5-54
Front lights	5-52
Interior lamp Auto off	5-52
Rear lamps	5-53
Vanity mirror lamp	5-54
Interior overview	2-6

J

Jump starting (12 V battery)	8-3
---	-----

L

Lane Following Assist (LFA)	7-109
Lane Following Assist malfunction and limitations	7-112
Lane Following Assist operation	7-110
Lane Following Assist settings	7-109
Lane Keeping Assist (LKA)	7-34
Lane Keeping Assist malfunction and limitations	7-39
Lane Keeping Assist operation	7-36
Lane Keeping Assist settings	7-35
Light bulbs	9-41
Headlight aiming	9-44
Headlight, position light, turn signal light, daytime running light (DRL) replacement	9-42
High mounted stop light replacement	9-49
Interior light replacement	9-49
License plate light replacement	9-49
Rear combination light replacement	9-47
Side repeater light replacement	9-47
Load and speed capacity tires	2-19

M

Maintenance services 9-4
 Owner maintenance precautions 9-4
 Owner's responsibility 9-4
Manual Speed Limit Assist (MSLA) 7-59
 Manual Speed Limit Assist operation 7-60
Mirrors 5-28
 Inside rearview mirror 5-28
 Outside rearview mirrors 5-29
Motor compartment 9-3
Motor compartment Overview 2-14
Motor number 2-21

N

Navigation-based Smart Cruise Control (NSCC) 7-103
 Limitations of Navigation-based Smart Cruise Control 7-106
 Navigation-based Smart Cruise Control Operation 7-104
 Navigation-based Smart Cruise Control Settings 7-104

O

Open source software notice 2-22
Owner maintenance 9-5
 Owner maintenance schedule 9-5

P

Pan-European eCall System (FOR EUROPE) 8-21
 Information on data processing (For Europe) 8-24
 Pan-European eCall System (For Europe) 8-26

R

Rear Cross-Traffic Collision-Avoidance Assist (RCCA) 7-130
 Rear Cross-Traffic Collision-Avoidance Assist malfunction and limitations 7-135
 Rear Cross-Traffic Collision-Avoidance Assist operation 7-132
 Rear Cross-Traffic Collision-Avoidance Assist settings 7-131
Rear Occupant Alert (ROA) 5-24
Rear View Monitor (RVM) 7-120
 Rear View Monitor malfunction and limitations 7-123
 Rear View Monitor operation 7-122
 Rear View Monitor settings 7-120
Recommended lubricants and capacities 2-20
Reduction gear 6-8
 Cluster display messages 6-12
 Good driving practices 6-13
 Reduction gear operation 6-8
Reduction gear fluid 9-15
Regenerative braking system 6-14
 One Pedal Driving 6-16
 Regenerative braking system limitations 6-15

Using i-PEDAL	6-17
Using regenerative braking system	6-14
Reverse Parking Collision-Avoidance Assist (PCA)	7-150
Reverse Parking Collision-Avoidance Assist malfunction and limitations	7-153
Reverse Parking Collision-Avoidance Assist operation	7-151
Reverse Parking Collision-Avoidance Assist settings	7-150
Reverse Parking Distance Warning (PDW)	7-140
Reverse Parking Distance Warning malfunction and limitations	7-142
Reverse Parking Distance Warning operation	7-142
Reverse Parking Distance Warning settings	7-140

S

Safe Exit Warning (SEW)	7-54
Safe Exit Warning malfunction and limitations	7-57
Safe Exit Warning operation	7-56
Safe Exit Warning settings	7-55
Scheduled maintenance services	9-7
Maintenance under severe usage conditions	9-10
Normal maintenance schedule	9-8
Seat belts	3-18
Additional seat belt safety precautions	3-23
Care of seat belts	3-25
Seat belt restraint system	3-20
Seat belt safety precautions	3-18
Seat belt warning light	3-19
Seats	3-5
Front seats	3-8
Headrest	3-13
Rear seats	3-10
Safety precautions	3-7
Seats warmers	3-16
Smart Cruise Control (SCC)	7-87
Smart Cruise Control malfunction and limitations	7-98
Smart Cruise Control operation	7-89
Smart Cruise Control settings	7-87
Smart regeneration system	6-18
Front sensors (Front radar)	6-20
Pausing smart regeneration system	6-20
Smart regeneration level settings	6-19
Smart regeneration system on/off	6-18
Smart regeneration system operating condition	6-19
Smart regeneration system precautions	6-21
System warning due to sensor problems	6-20
Special driving conditions	6-40
Driving at night	6-41
Driving in flooded areas	6-41
Driving in the rain	6-41
Hazardous driving conditions	6-40
Highway driving	6-42
Rocking the vehicle	6-40

Smooth cornering	6-41
Start/Stop button	6-4
Remote start	6-8
Start/Stop button position	6-5
Starting the vehicle	6-6
Turning off the vehicle	6-7
Steering wheel	5-25
Horn	5-27
Motor Driven Power Steering (MDPS)	5-25
Steering wheel heater	5-26
Tilt/Telescopic steering	5-25
Steering wheel control overview	2-13
Storage compartment	5-74
Cargo tray	5-75
Center console storage	5-74
Glove box	5-75
Passenger seat open tray	5-75
Sunroof	5-34
Automatic reversal	5-36
Resetting the sunroof	5-37
Slide open/close	5-36
Sunroof open warning	5-38
Sunshade	5-35
Tilt open/close	5-35
Surround View Monitor (SVM)	7-124
Surround View Monitor malfunction and limitations	7-129
Surround View Monitor operation	7-126
Surround View Monitor settings	7-125

T

Tailgate	5-39
Closing the tailgate	5-40
Emergency tailgate safety release	5-40
Opening the tailgate	5-39
Theft-alarm system	5-23
Tire pressure monitoring system (TPMS)	8-7
Low tire pressure light	8-8
Resetting TPMS	8-7
TPMS malfunction indicator	8-10
Tire specification and pressure label	2-21
Tires and wheels	2-18, 9-22
Check tire inflation pressure	9-23
Low aspect ratio tires	9-28
Recommended cold tire inflation pressures	9-22
Tire care	9-22
Tire maintenance	9-26
Tire replacement	9-25
Tire rotation	9-24
Tire sidewall labeling	9-26
Tire traction	9-25

Wheel alignment and tire balance	9-24
Wheel replacement	9-25
Towing	8-17
Removable towing hook	8-18
Towing service	8-17
Trailer towing	6-45

U

UAE eCall System (For UAE)	8-30
eCall certification label	8-38
Information on data processing (For UAE)	8-33
UAE eCall System (For UAE)	8-35
Understanding your electric vehicle	1-8
Characteristics of your electric vehicle	1-8
Other precautions for electric vehicle management	1-11
Precautions when using the high voltage battery	1-10
Using Electric Vehicle functions	1-31
Checking energy information	1-32
Checking the Electric Vehicle screen configuration	1-31
Setting a battery discharging limit when using Vehicle to Load (V2L)	1-37
Setting electric vehicle specialized functions	1-38
Setting the charging and climate	1-35
Setting the next departure time	1-34
Using V2L function	1-42
Safety precautions when using the V2L function	1-42
Solving V2L problems	1-47
Using electricity inside the vehicle	1-45
Using electricity outside the vehicle	1-44

V

Vehicle certification label	2-21
Vehicle data collection and event data recorders	1-7
Vehicle Identification Number (VIN)	2-21
Vehicle settings (infotainment system)	4-34
Setting your vehicle	4-34
Vehicle system OTA update	5-42
Approving software update	5-42
Downloading software	5-42
Preparing software update	5-42
Updating software	5-43
Vehicle weight	6-46
Overloading	6-46
Vehicle weight and luggage volume	2-20
Vetrarakstur	A-2
Snjór eða hálka	A-2

W

Washer fluid	9-15
Checking the washer fluid level	9-15

Windows	5-31
Power windows	5-31
Windshield defrosting (Heater)	5-71
Windshield defrosting and defogging	5-69
Automatic climate control system	5-70
Defogging logic	5-70
Rear window defroster	5-71
Winter driving	6-43
Snow or icy conditions	6-43
Winter precautions	6-44
Wiper blades	9-17
Blade inspection	9-17
Blade replacement	9-17
Wipers and washers	5-55
Front windshield washers	5-56
Front windshield wipers	5-55
Rear windshield washers	5-57
Rear windshield wipers	5-57